

EXCEPT AS OTHERWISE PROVIDED BY CONTRACT, THIS DRAWING AND SPECIFICATIONS SHALL NOT BE REPRODUCED, COPIED OR USED AS THE BASIS FOR MANUFACTURE OR SALE OF MATTER DEPICTED HEREIN WITHOUT THE EXPRESSED WRITTEN PERMISSION OF THE CLAUDE LAVAL CORPORATION, OR ITS ASSIGNEES.

NOTES:

1. INLET & OUTLET ARE 1-1/2" GROOVED PIPE.
2. MAXIMUM PRESSURE: 150 psi (10.3 bar).
3. MAXIMUM TEMPERATURE: 180°F (82.2°C).
4. PRESSURE LOSS: 3-12 psid (.2-.8 barg) AT RATED FLOW.
5. RATED FLOW: 38-65 gpm (9-15 m³/hr).
6. APPROXIMATE DRY WEIGHT: 85 lbs (39 kg).
7. FINISH: LAKOS BLUE (EXTERIOR ONLY).

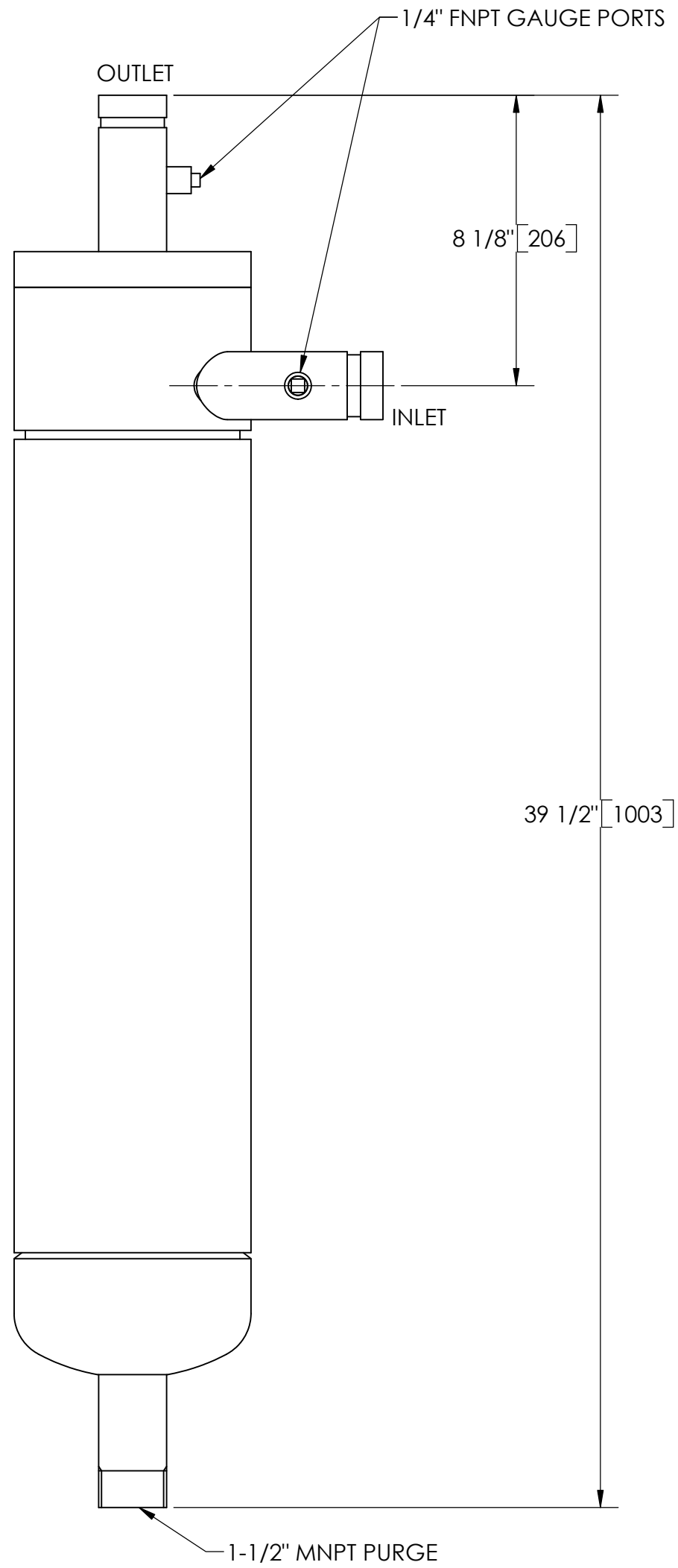

THIS DRAWING HAS BEEN GENERATED AND IS MAINTAINED BY A CAD SYSTEM. CHANGES SHALL ONLY BE INCORPORATED AS DIRECTED BY AN APPROVED ENGINEERING CHANGE ORDER (ECO). PAPER COPIES ARE UNCONTROLLED.

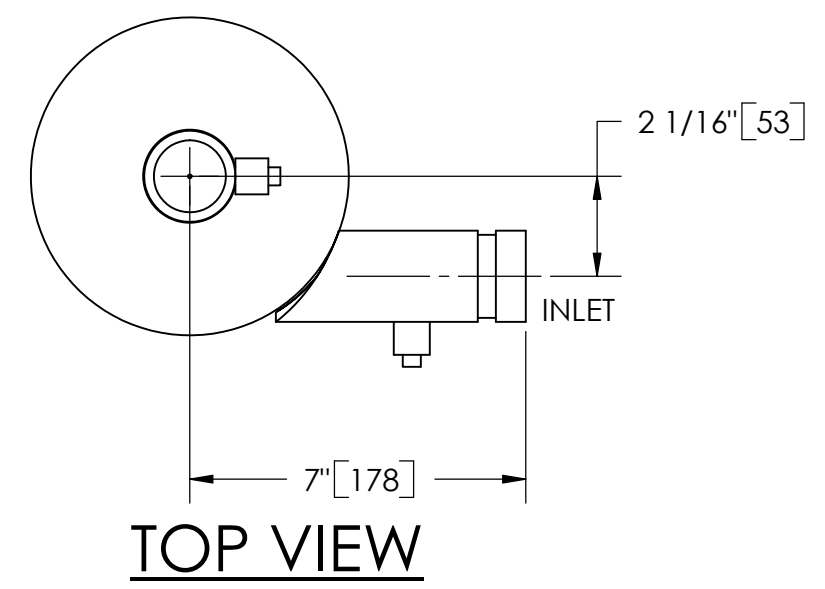

REVISION HISTORY				
ZONE	REV	DESCRIPTION	DATE	APPROVED

SUBMITTAL DRAWING

This drawing is submitted for spatial consideration only. Do not pre-plumb to these dimensions.

UNLESS OTHERWISE SPECIFIED: DIMENSIONS ARE IN: INCHES [mm] TOLERANCES ARE: FRACTIONS DECIMALS ANGLES ± 1/4" .XX ± .01 ± 1/4° .XXX ± .005 .XXXX ± .0005		ENGINEERED FOR: STANDARD		CLAUDE LAVAL CORP. FRESNO, CALIFORNIA 93727 WWW.LAKOS.COM		LAVAL UNDERGROUND SURVEYS	
DO NOT SCALE DRAWING		APPROVALS	DATE	TITLE			
MATERIAL CLASS P-1 MILD CARBON STEEL		DRAWN DLW	1/16/06	JPL-0038, SEPARATOR, 38-65 gpm, CARBON STEEL			
FINISH LAKOS BLUE		ENGR β	2/3/06	SIZE C	MODEL NO.	DWG NO. 116532	REV. C
		WORK ORDER	QTY.	SCALE 1:4	EST. WT. 86 lb	SHEET 1 OF 1	

DWG NO. 116532
 SHEET 1
 REV. C