

EXCEPT AS OTHERWISE PROVIDED BY CONTRACT, THIS DRAWING AND SPECIFICATIONS SHALL NOT BE REPRODUCED, COPIED OR USED AS THE BASIS FOR MANUFACTURE OR SALE OF MATTER DEPICTED HEREIN WITHOUT THE EXPRESSED WRITTEN PERMISSION OF THE CLAUDE LAVAL CORPORATION, OR ITS ASSIGNEES.

NOTES:

1. INLET & OUTLET ARE 16" GROOVED PIPE.
2. MAXIMUM PRESSURE: 150 psi (10.3 bar).
3. MAXIMUM TEMPERATURE: 180°F (82.2°C).
4. PRESSURE LOSS: 3-12 psid (.2-.8 bar) AT RATED FLOW.
5. RATED FLOW: 4200-7800 gpm (950-1775 m³/hr).
6. APPROXIMATE DRY WEIGHT: 6024 lbs (2732 kg).
7. FINISH: LAKOS BLUE (EXTERIOR ONLY).

REVISIONS				
ECN	REV.	DESCRIPTION	DATE	APPROVED

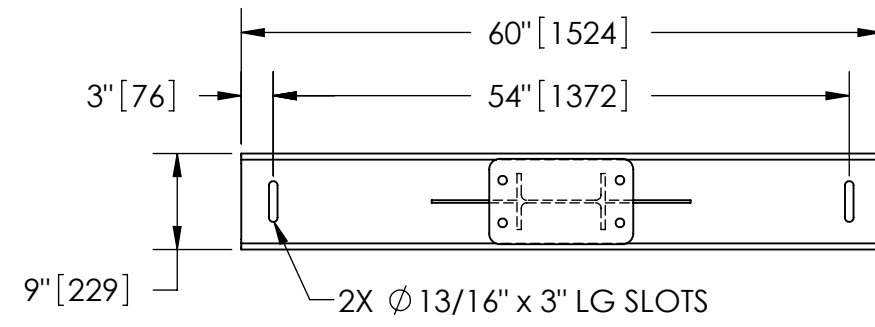

SECTION B-B

THIS DRAWING HAS BEEN GENERATED AND IS MAINTAINED BY A CAD SYSTEM. CHANGES SHALL ONLY BE INCORPORATED AS DIRECTED BY AN APPROVED ENGINEERING CHANGE ORDER (ECO). PAPER COPIES ARE UNCONTROLLED.

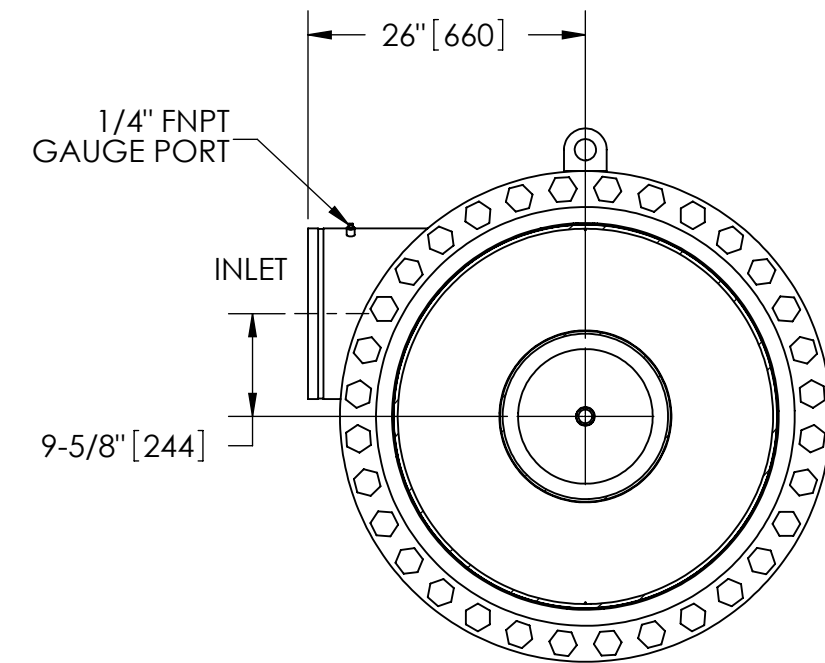

SECTION A-A

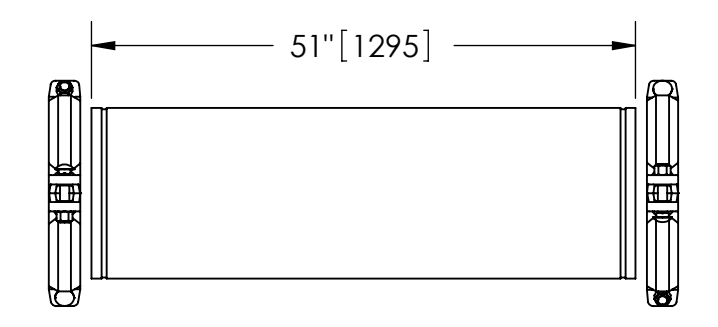
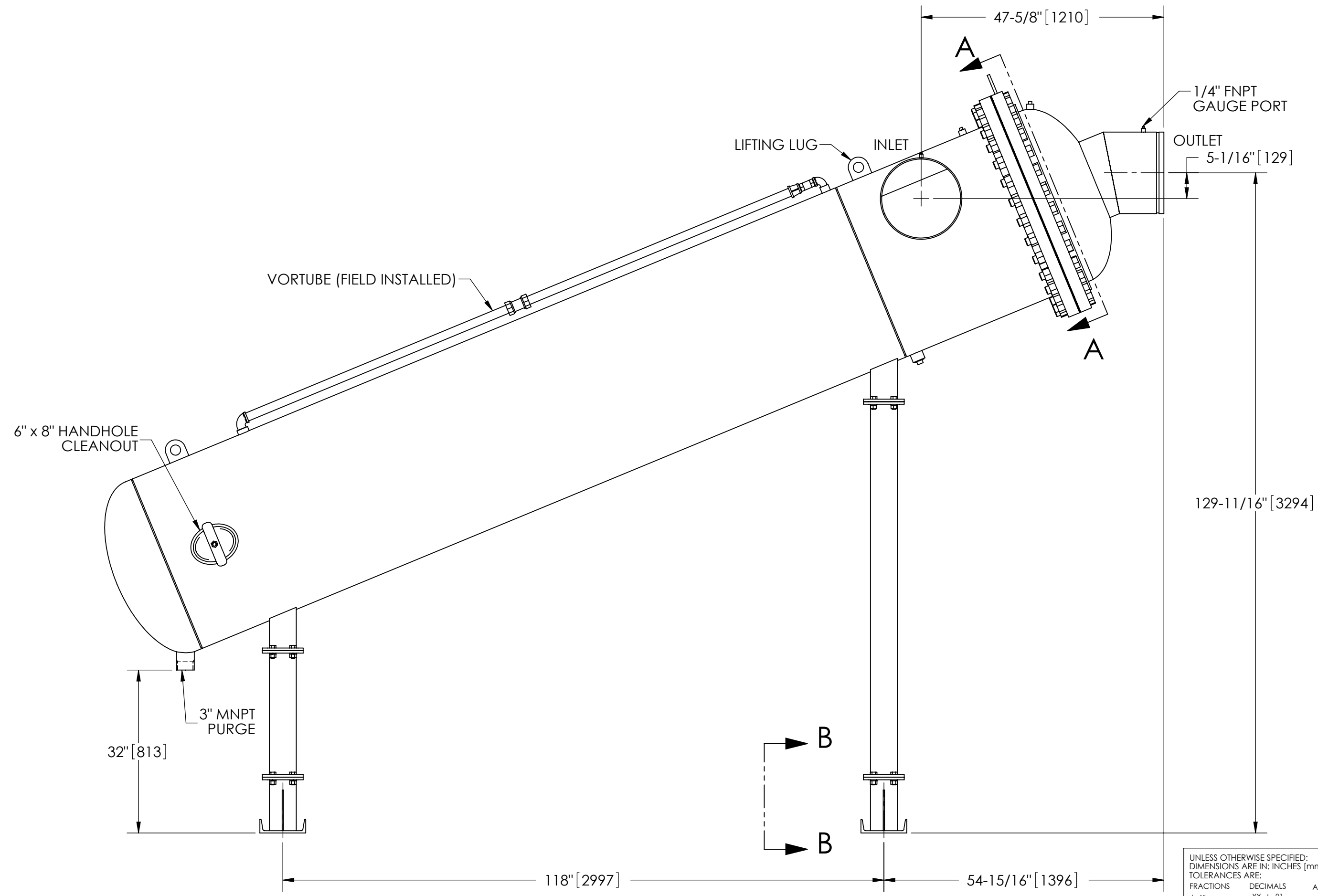

**GROOVED SPOOL**  
 MODEL GCS-4200 (AVAILABLE SEPARATELY)  
 REQUIRED FOR REMOVAL OF TOP ASSEMBLY

**SUBMITTAL DRAWING**

This drawing is submitted for spatial consideration only. Do not pre-plumb to these dimensions.

UNLESS OTHERWISE SPECIFIED: DIMENSIONS ARE IN: INCHES [mm] TOLERANCES ARE: FRACTIONS .XX ± .01 ANGLES ± 1/4° ± 1" .XXX ± .005 XXX ± .0005		ENGINEERED FOR: <b>STANDARD</b>		CLAUDE LAVAL CORP. FRESNO, CALIFORNIA 93727 WWW.LAKOS.COM		LAVAL UNDERGROUND SURVEYS	
DO NOT SCALE DRAWING		APPROVALS	DATE	TITLE JPX-4200-L, SEPARATOR, 4200-7800 gpm, CARBON STEEL			
MATERIAL CLASS P-1 MILD CARBON STEEL	ENGR β	1/26/06	2/6/06	SIZE C	MODEL NO.	DWG NO. <b>115255</b>	REV. E
FINISH LAKOS BLUE	WORK ORDER	QTY.	SCALE 1:18	EST. WT. 6024 lb	SHEET 1 OF 1		

DWG. NO. 115255  
 SH 1  
 REV. E