

EXCEPT AS OTHERWISE PROVIDED BY CONTRACT, THIS DRAWING AND SPECIFICATIONS SHALL NOT BE REPRODUCED, COPIED OR USED AS THE BASIS FOR MANUFACTURE OR SALE OF MATTER DEPICTED HEREIN WITHOUT THE EXPRESSED WRITTEN PERMISSION OF THE CLAUDE LAVAL CORPORATION, OR ITS ASSIGNEES.

NOTES:

1. INLET & OUTLET ARE 16" GROOVED PIPE.
2. MAXIMUM PRESSURE: 150 psi (10.3 bar).
3. MAXIMUM TEMPERATURE: 180°F (82.2°C).
4. PRESSURE LOSS: 3-12 psid (.2-.8 bar) AT RATED FLOW.
5. RATED FLOW: 4200-7800 gpm (950-1775 m³/hr).
6. APPROXIMATE DRY WEIGHT: 5761 lbs (2613 kg).
7. FINISH: LAKOS BLUE (EXTERIOR ONLY).

REVISIONS				
ECN	REV.	DESCRIPTION	DATE	APPROVED

THIS DRAWING HAS BEEN GENERATED AND IS MAINTAINED BY A CAD SYSTEM. CHANGES SHALL ONLY BE INCORPORATED AS DIRECTED BY AN APPROVED ENGINEERING CHANGE ORDER (ECO). PAPER COPIES ARE UNCONTROLLED.

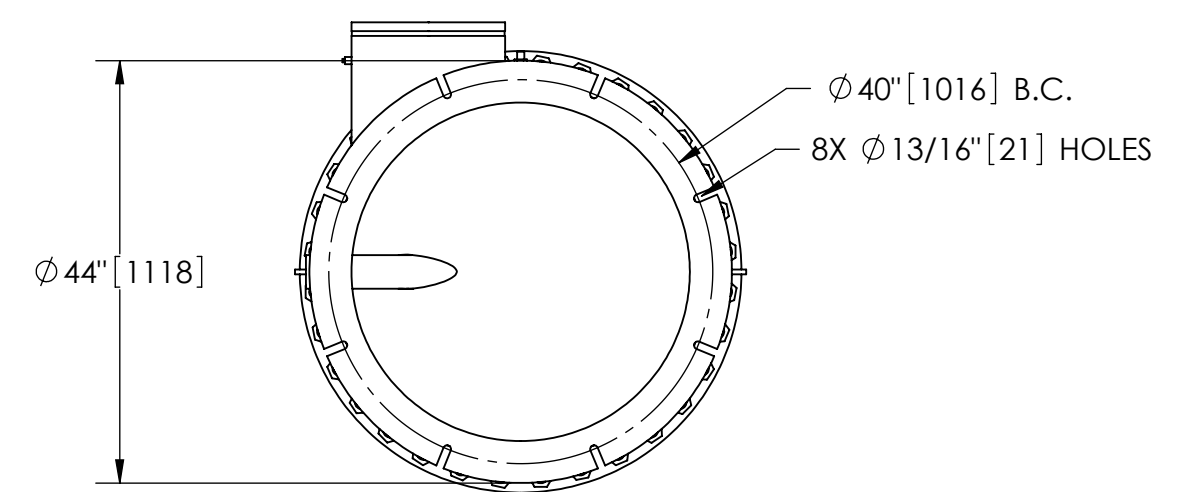
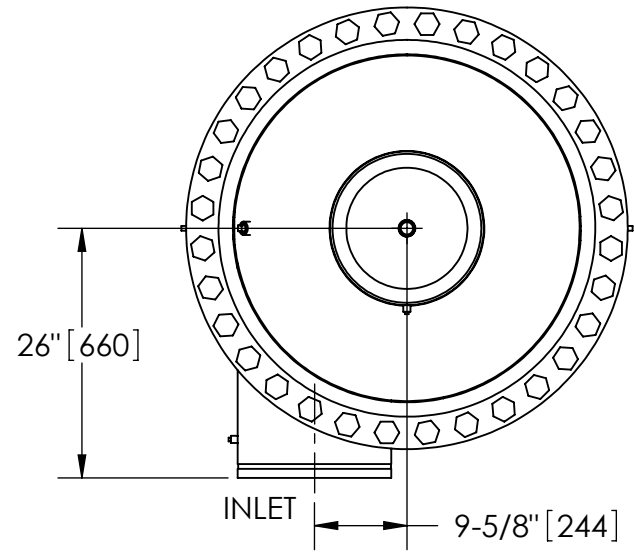

**BOTTOM VIEW**

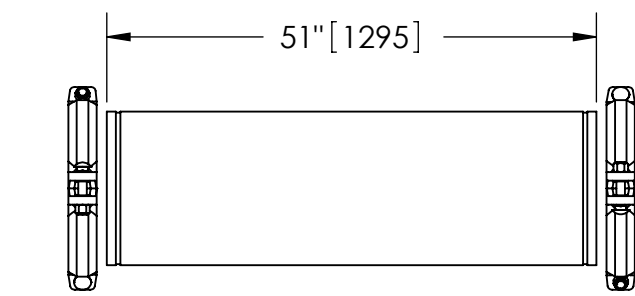

**GROOVED SPOOL**  
MODEL GCS-3500/4200 (AVAILABLE SEPARATELY)  
REQUIRED FOR REMOVAL OF TOP ASSEMBLY

**SUBMITTAL DRAWING**

This drawing is submitted for spatial consideration only. Do not pre-plumb to these dimensions.

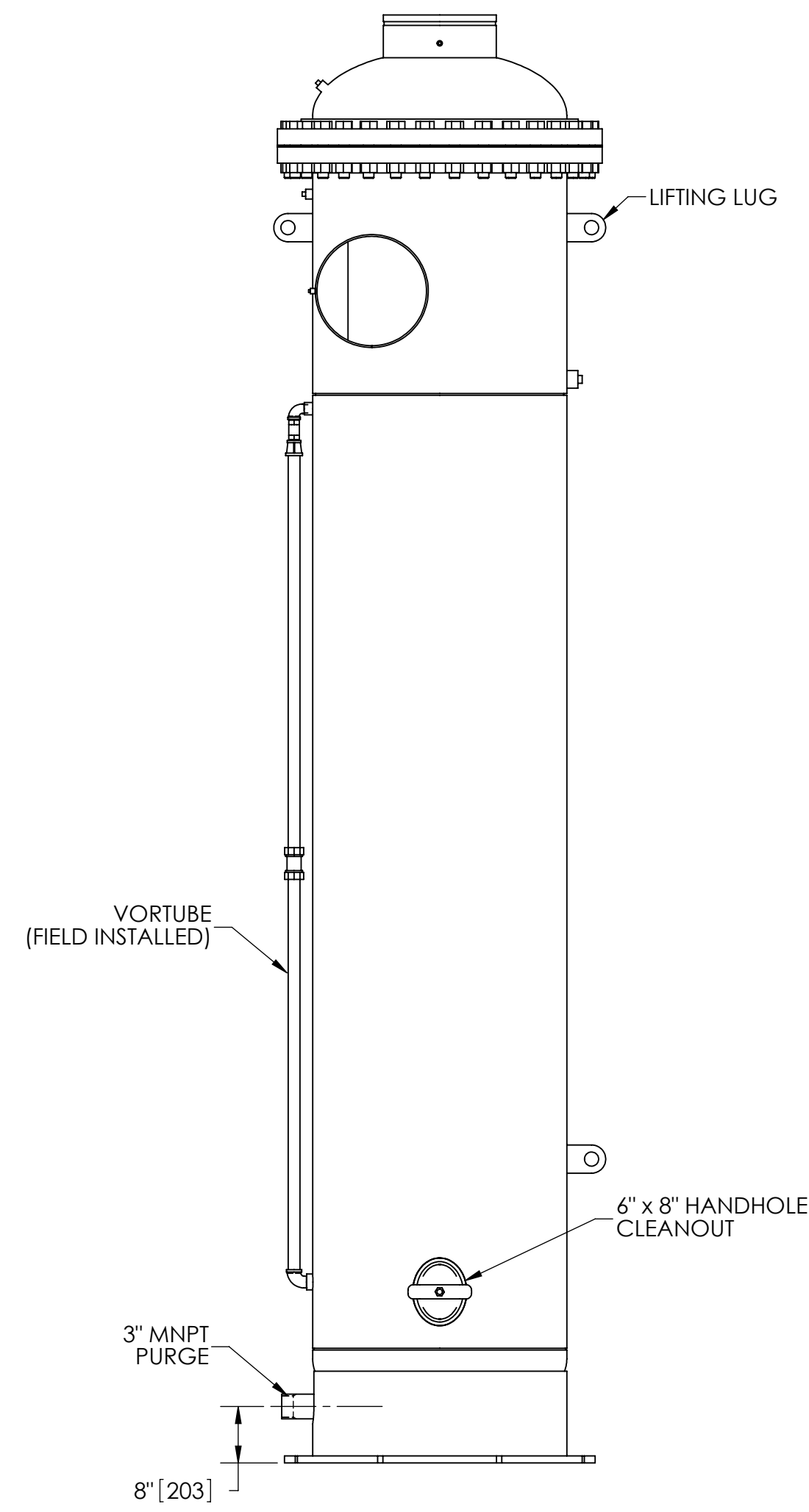
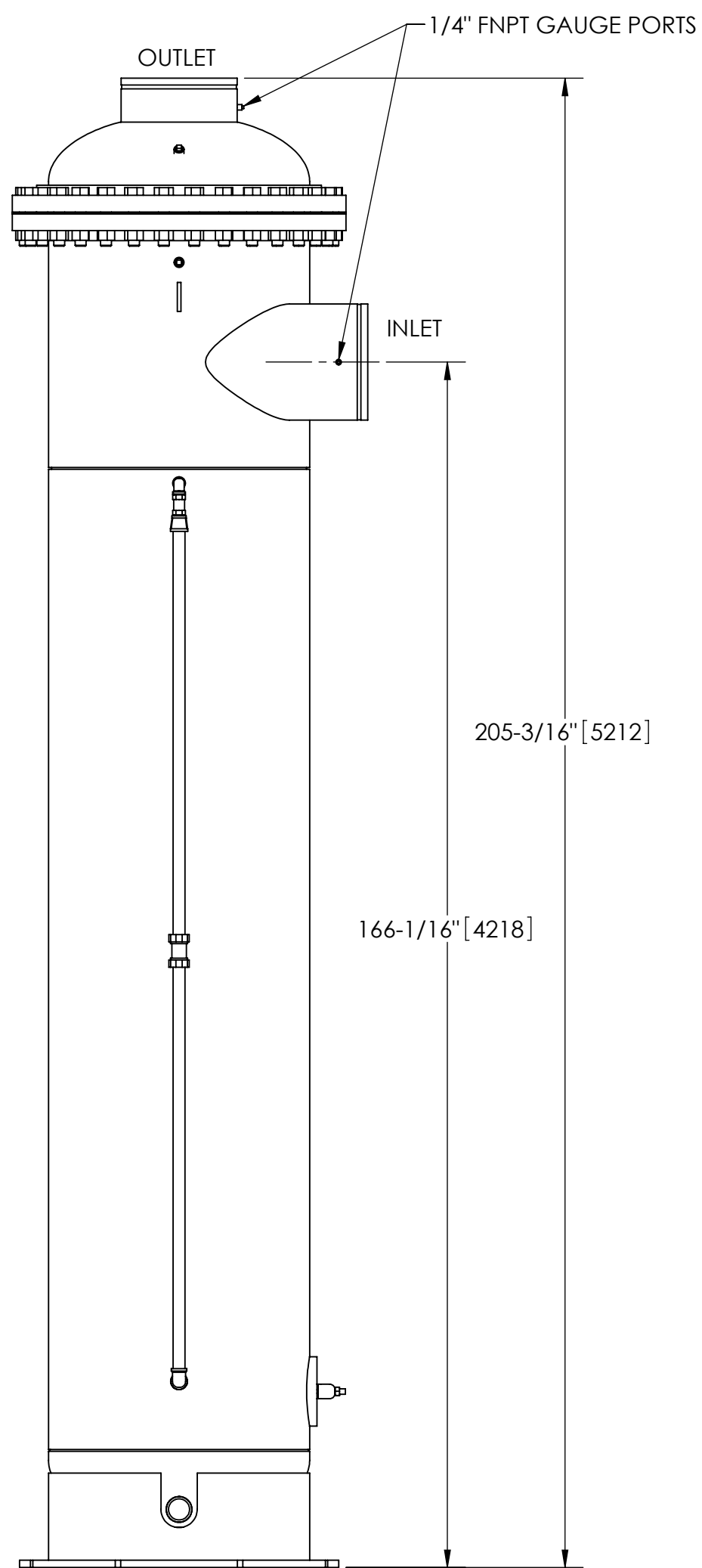

UNLESS OTHERWISE SPECIFIED: DIMENSIONS ARE IN: INCHES [mm] TOLERANCES ARE: FRACTIONS    DECIMALS    ANGLES ± 1"        .XX ± .01        ± 1/4° .XXX ± .005 .XXXX ± .0005		ENGINEERED FOR: <b>STANDARD</b>		CLAUDE LAVAL CORP. FRESNO, CALIFORNIA 93727 WWW.LAKOS.COM		LAVAL UNDERGROUND SURVEYS	
DO NOT SCALE DRAWING		APPROVALS	DATE	TITLE			
MATERIAL CLASS P-1 MILD CARBON STEEL		DRAWN DLW	1/27/06	JPX-4200-V, SEPARATOR, 4200-7800 gpm, CARBON STEEL			
FINISH LAKOS BLUE		ENGR β	2/6/06	SIZE C	MODEL NO.	DWG NO. 115256	REV. E
SCALE 1:20		WORK ORDER	QTY.	EST. WT. 5761 lb	SHEET 1 OF 1		