

EXCEPT AS OTHERWISE PROVIDED BY CONTRACT, THIS DRAWING AND SPECIFICATIONS SHALL NOT BE REPRODUCED, COPIED OR USED AS THE BASIS FOR MANUFACTURE OR SALE OF MATTER DEPICTED HEREIN WITHOUT THE EXPRESSED WRITTEN PERMISSION OF THE CLAUDE LAVAL CORPORATION, OR ITS ASSIGNEES.

NOTES:

1. INLET & OUTLET ARE 4" GROOVED PIPE.
2. MAXIMUM PRESSURE: 150 psi (10.3 bar).
3. MAXIMUM TEMPERATURE: 180°F (82.2°C).
4. PRESSURE LOSS: 3-12 psid (.2-.8 bar) AT RATED FLOW.
5. RATED FLOW: 200-325 gpm (45-74 m³/hr).
6. APPROXIMATE DRY WEIGHT: 414 lbs (188 kg).
7. FINISH: LAKOS BLUE (EXTERIOR ONLY).

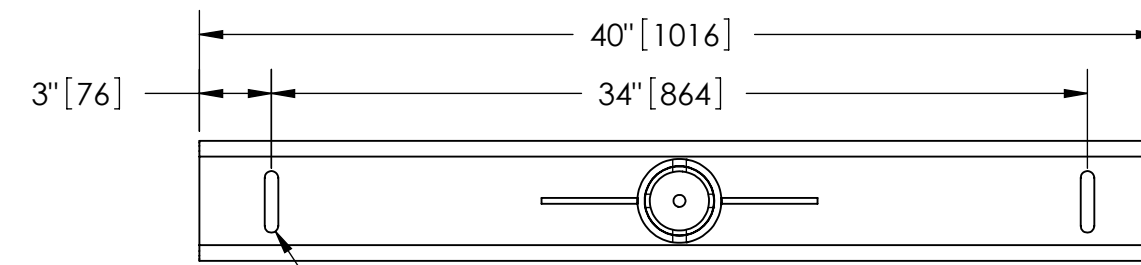

2X 9/16" x 2" LG SLOTS

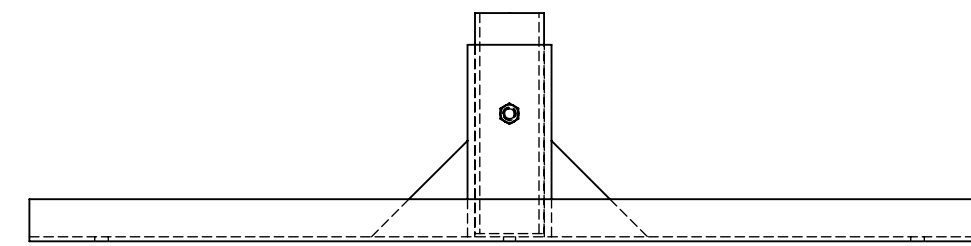

SECTION B-B

REVISION HISTORY				
ZONE	REV	DESCRIPTION	DATE	APPROVED

THIS DRAWING HAS BEEN GENERATED AND IS MAINTAINED BY A CAD SYSTEM. CHANGES SHALL ONLY BE INCORPORATED AS DIRECTED BY AN APPROVED ENGINEERING CHANGE ORDER (ECO). PAPER COPIES ARE UNCONTROLLED.

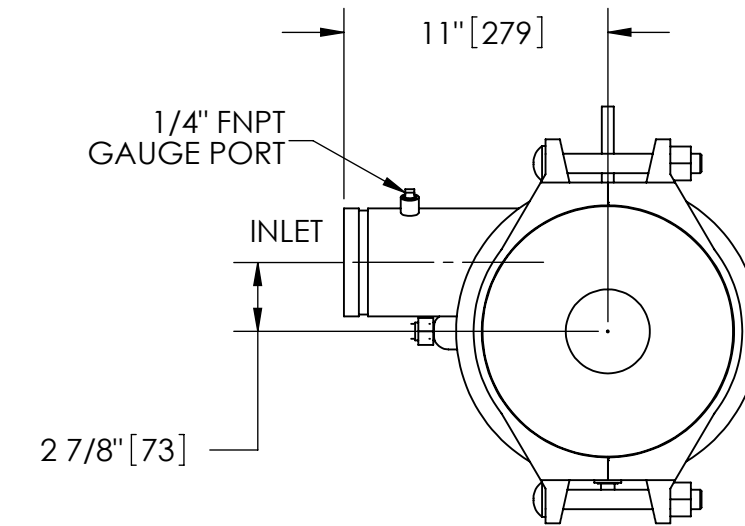

SECTION A-A

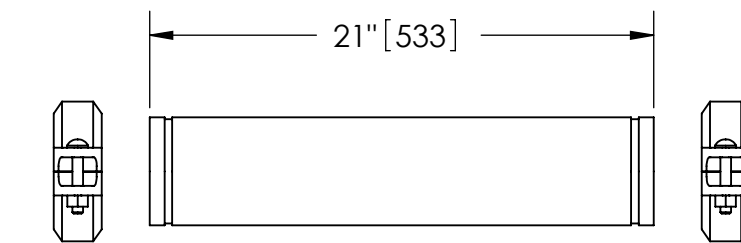

GROOVED SPOOL
 MODEL GCS-0200/0285 (AVAILABLE SEPARATELY)
 REQUIRED FOR REMOVAL OF TOP ASSEMBLY

SUBMITTAL DRAWING

This drawing is submitted for spatial consideration only. Do not pre-plumb to these dimensions.

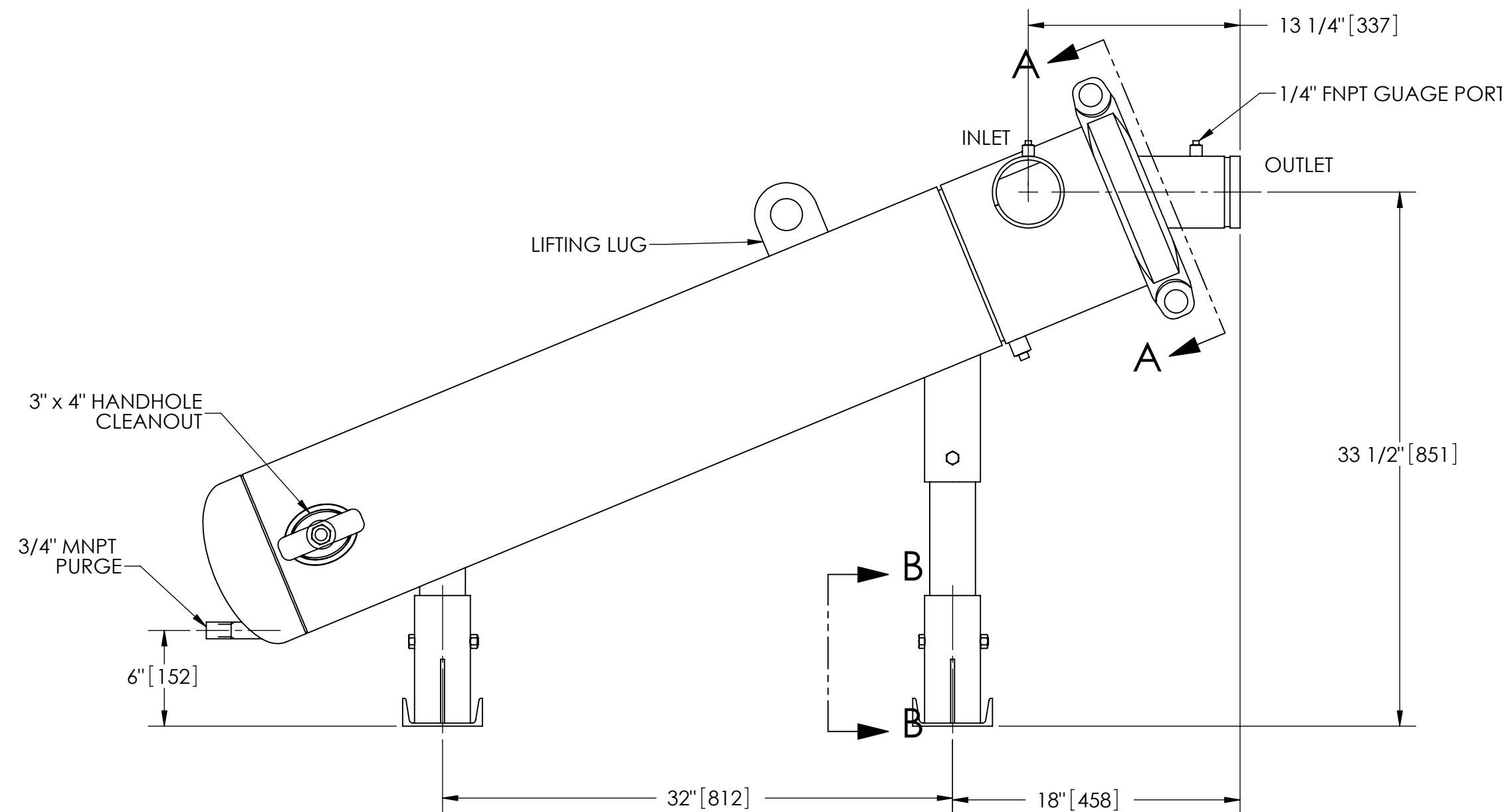

UNLESS OTHERWISE SPECIFIED: DIMENSIONS ARE IN: INCHES (mm) TOLERANCES ARE: FRACTIONS DECIMALS ANGLES ± 1/4" .XX ± .01 ± 1/4° .XXX ± .005 .XXXX ± .0005		ENGINEERED FOR: STANDARD		CLAUDE LAVAL CORP. FRESNO, CALIFORNIA 93727 WWW.LAKOS.COM		LAVAL UNDERGROUND SURVEYS	
DO NOT SCALE DRAWING		APPROVALS	DATE	TITLE			
MATERIAL		DRAWN	ENGR	HTX-0200-L, SEPARATOR, 200-325 gpm, CARBON STEEL			
FINISH		MFG	WORK ORDER	SCALE	MODEL NO.	DWG NO.	REV.
LAKOS BLUE		-	-	C		120414	C
				1:8		EST. WT. 409 lb	SHEET 1 OF 1