

EXCEPT AS OTHERWISE PROVIDED BY CONTRACT, THIS DRAWING AND SPECIFICATIONS SHALL NOT BE REPRODUCED, COPIED OR USED AS THE BASIS FOR MANUFACTURE OR SALE OF MATTER DEPICTED HEREIN WITHOUT THE EXPRESSED WRITTEN PERMISSION OF THE CLAUDE LAVAL CORPORATION, OR ITS ASSIGNEES.

NOTES:

1. INLET & OUTLET ARE 6" GROOVED PIPE.
2. MAXIMUM PRESSURE: 150 psi (10.3 bar).
3. MAXIMUM TEMPERATURE: 180°F (82.2°C).
4. PRESSURE LOSS: 3-12 psid (.2-.8 bar) AT RATED FLOW.
5. RATED FLOW: 500-1100 gpm (114-250 m³/hr).
6. APPROXIMATE DRY WEIGHT: 600 lbs (272 kg).
7. FINISH: LAKOS BLACK (EXTERIOR ONLY).

REVISION HISTORY				
ZONE	REV	DESCRIPTION	DATE	APPROVED

THIS DRAWING HAS BEEN GENERATED AND IS MAINTAINED BY A CAD SYSTEM. CHANGES SHALL ONLY BE INCORPORATED AS DIRECTED BY AN APPROVED ENGINEERING CHANGE ORDER (ECO). PAPER COPIES ARE UNCONTROLLED.

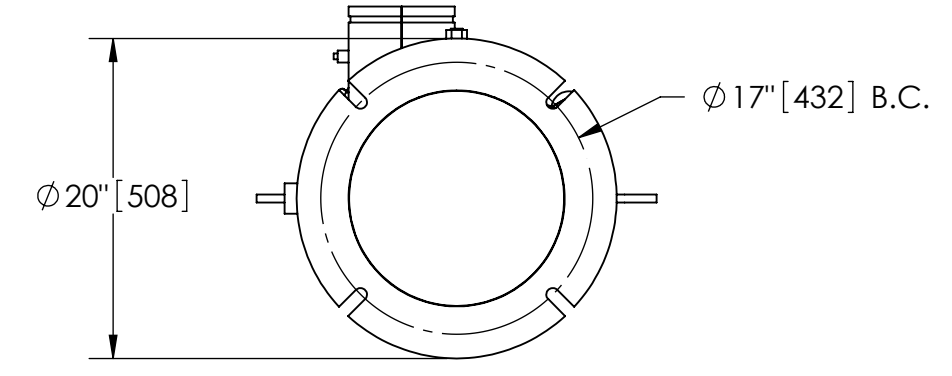
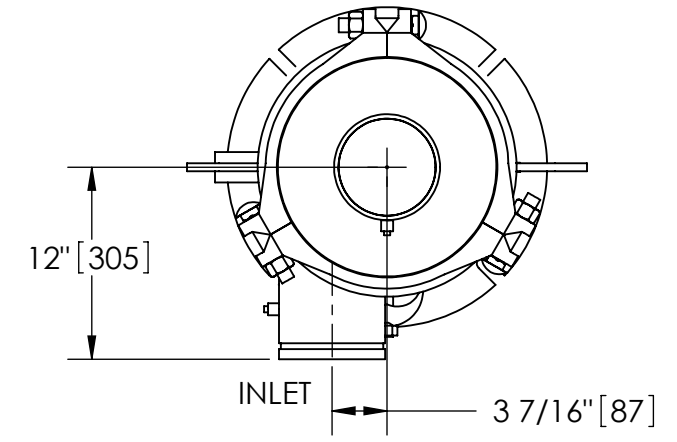

BOTTOM VIEW

GROOVED SPOOL

MODEL GCS-0450/0500/0650 (AVAILABLE SEPARATELY)
REQUIRED FOR REMOVAL OF TOP ASSEMBLY

SUBMITTAL DRAWING

This drawing is submitted for spatial consideration only. Do not pre-plumb to these dimensions.

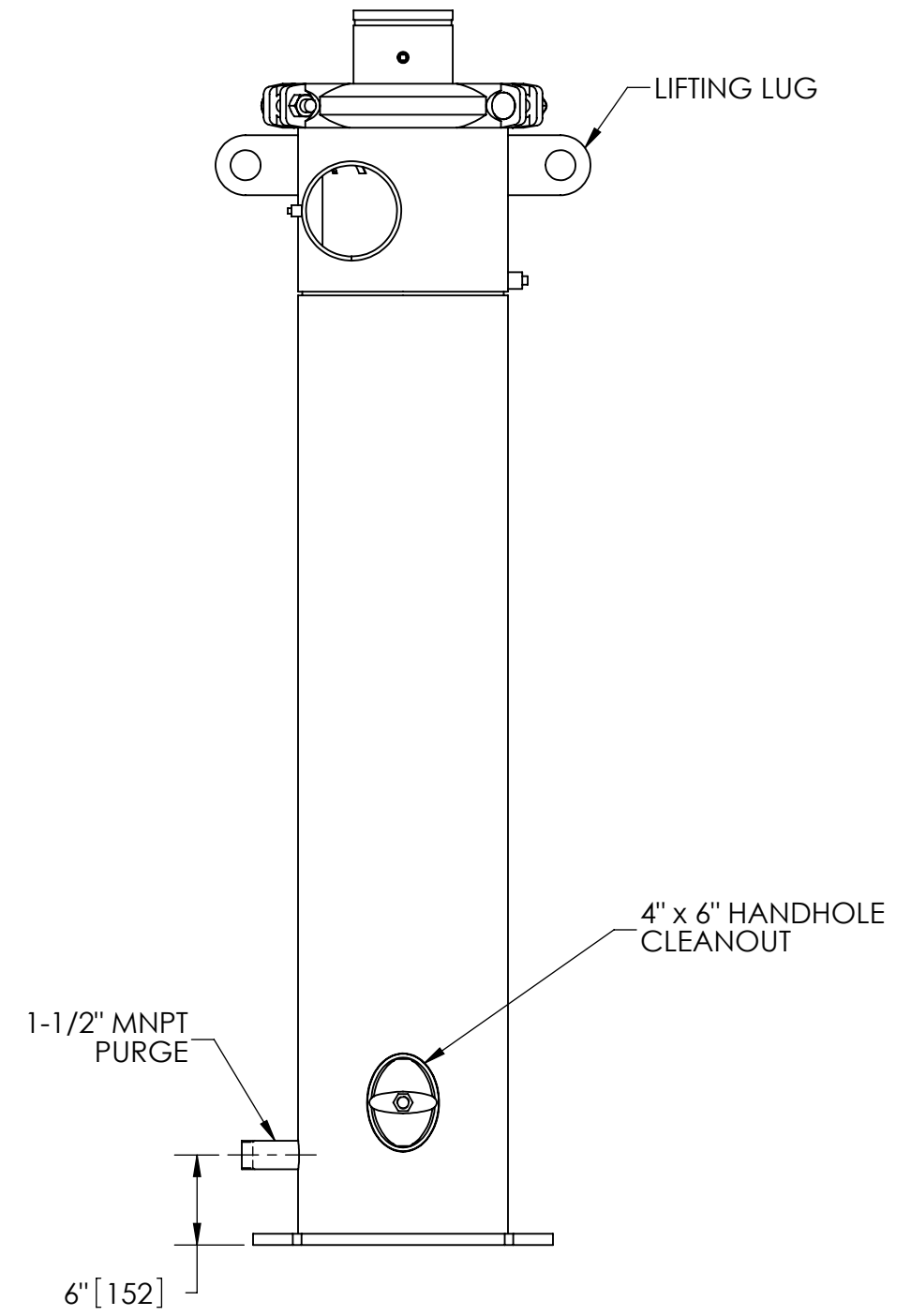
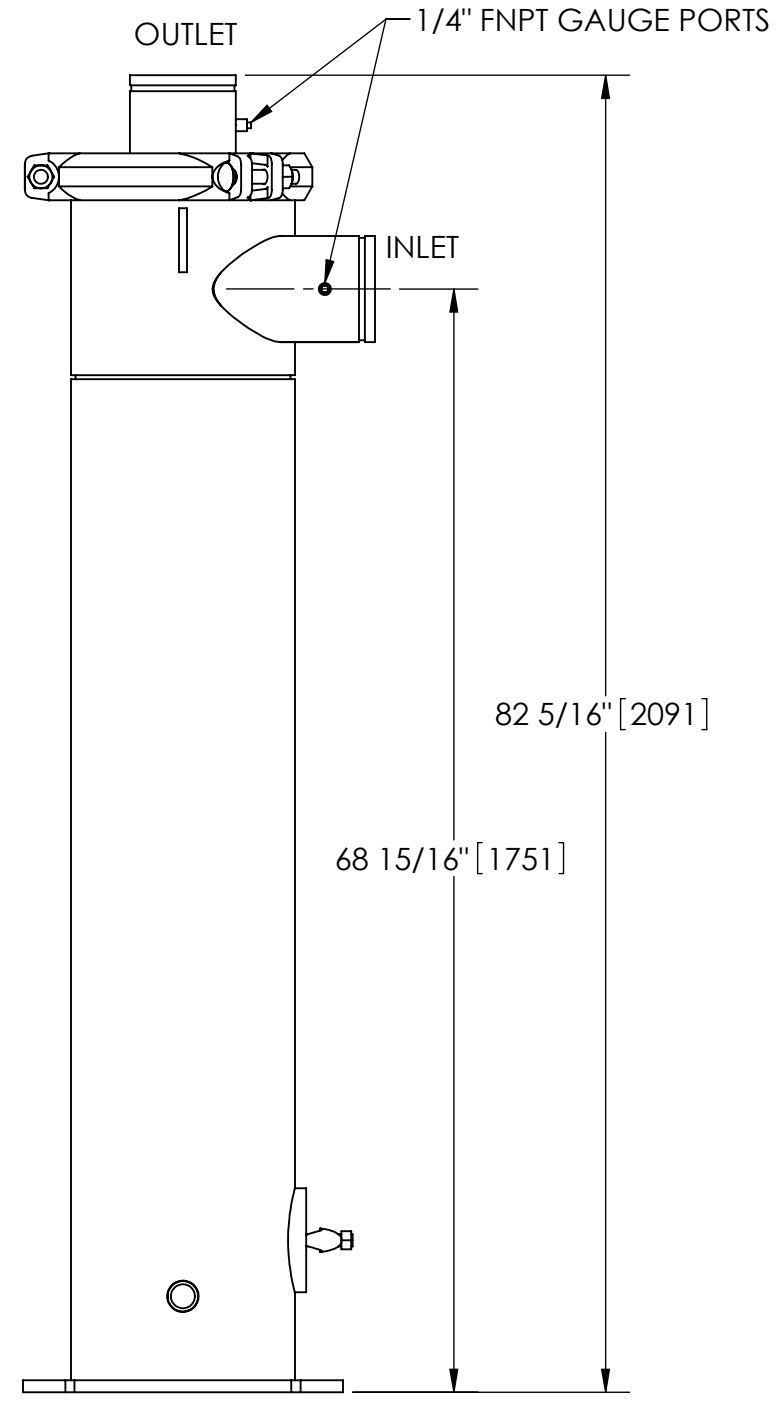

UNLESS OTHERWISE SPECIFIED: DIMENSIONS ARE IN: INCHES [mm] TOLERANCES ARE:		ENGINEERED FOR: STANDARD		CLAUDE LAVAL CORP. FRESNO, CALIFORNIA 93727 WWW.LAKOS.COM		LAVAL UNDERGROUND SURVEYS		
FRACTIONS ± 1/2"	DECIMALS .XX ± .01 .XXX ± .005 .XXXX ± .0005	ANGLES ± 1/4°	APPROVALS	DATE	TITLE HTX-0500-V, SEPARATOR, 500-1100 gpm, CARBON STEEL			
DO NOT SCALE DRAWING			DRAWN DLW	1/27/06	SIZE C	MODEL NO.	DWG NO. 115282	REV. E
MATERIAL CLASS P-1 MILD CARBON STEEL			ENGR β	2/3/06	SCALE 1:12	EST. WT. 600 lb	SHEET 1 OF 1	
FINISH LAKOS BLACK			MFG -	-				
			WORK ORDER	QTY.				

DWG. NO. 115282 SHEET 1 REV. E