

EXCEPT AS OTHERWISE PROVIDED BY CONTRACT, THIS DRAWING AND SPECIFICATIONS SHALL NOT BE REPRODUCED, COPIED OR USED AS THE BASIS FOR MANUFACTURE OR SALE OF MATTER DEPICTED HEREIN WITHOUT THE EXPRESSED WRITTEN PERMISSION OF THE CLAUDE LAVAL CORPORATION, OR ITS ASSIGNEES.

NOTES:

1. INLET & OUTLET ARE 16" GROOVED PIPE.
2. MAXIMUM PRESSURE: 150 psi (10.3 bar).
3. MAXIMUM TEMPERATURE: 180°F (82.2°C).
4. PRESSURE LOSS: 3-12 psid (.2-.8 bar) AT RATED FLOW.
5. RATED FLOW: 3500-6800 gpm (795-1545 m³/hr).
6. APPROXIMATE DRY WEIGHT: 4027 lbs (1827 kg).
7. FINISH: LAKOS BLACK (EXTERIOR ONLY).

| REVISION HISTORY | | | | |
|------------------|-----|-------------|------|----------|
| ZONE | REV | DESCRIPTION | DATE | APPROVED |
| | | | | |

THIS DRAWING HAS BEEN GENERATED AND IS MAINTAINED BY A CAD SYSTEM. CHANGES SHALL ONLY BE INCORPORATED AS DIRECTED BY AN APPROVED ENGINEERING CHANGE ORDER (ECO). PAPER COPIES ARE UNCONTROLLED.

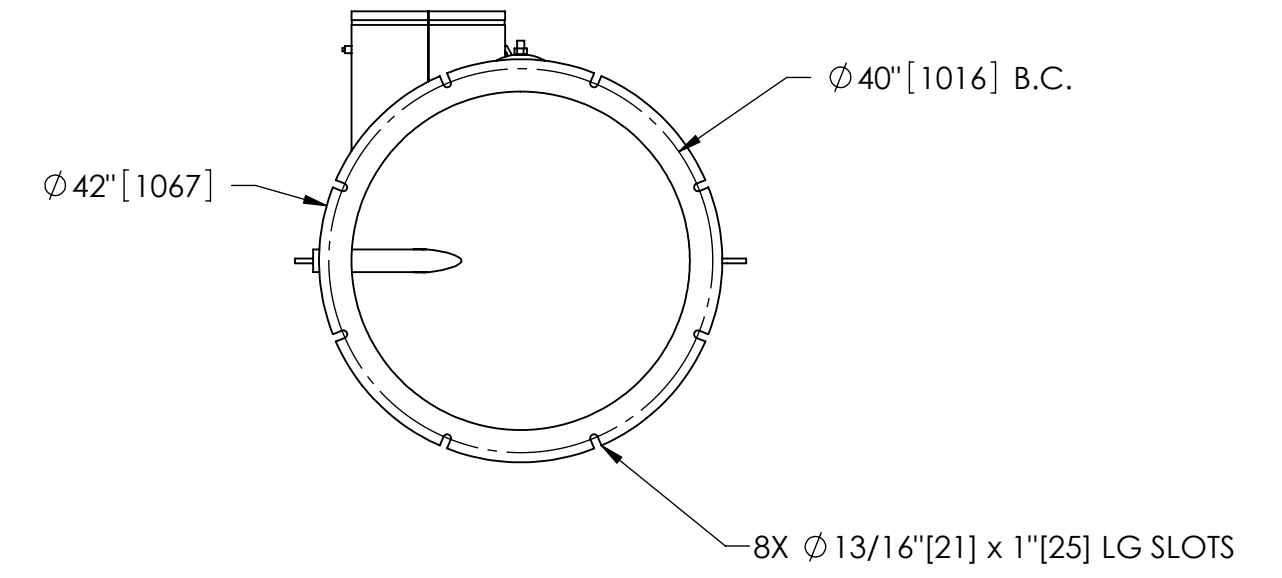
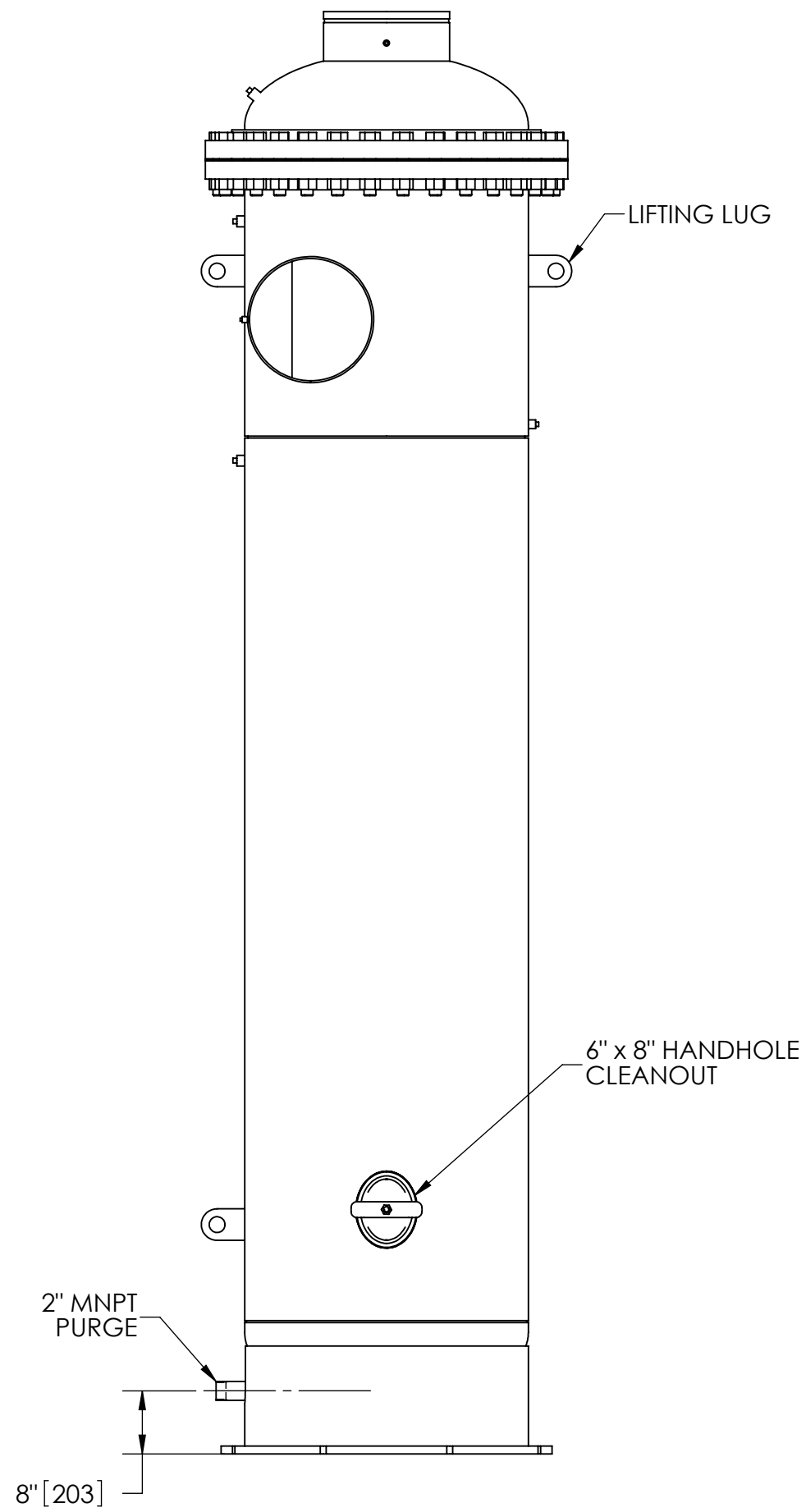
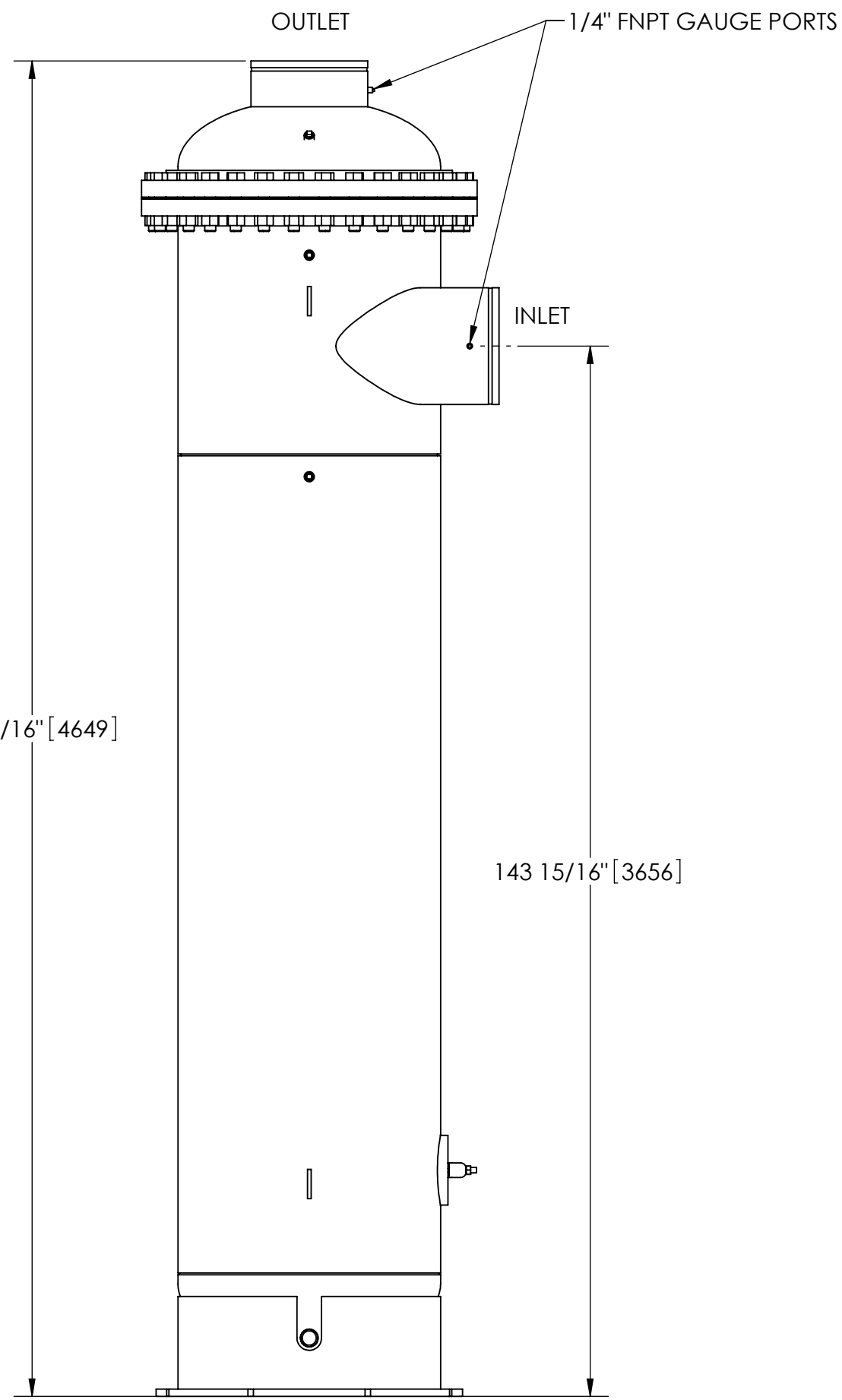
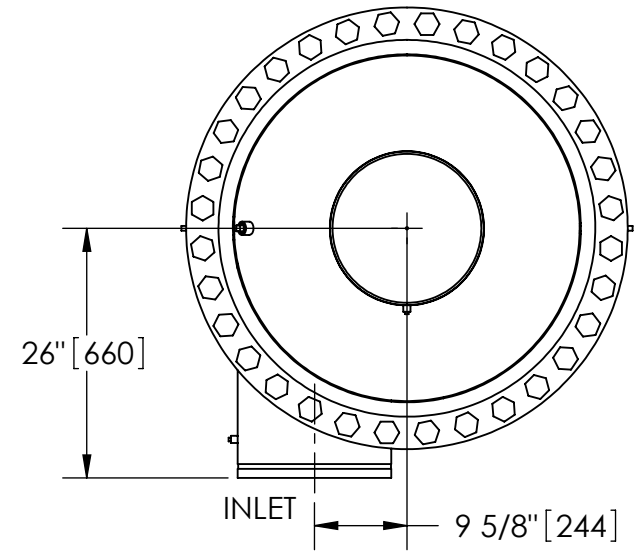

BOTTOM VIEW

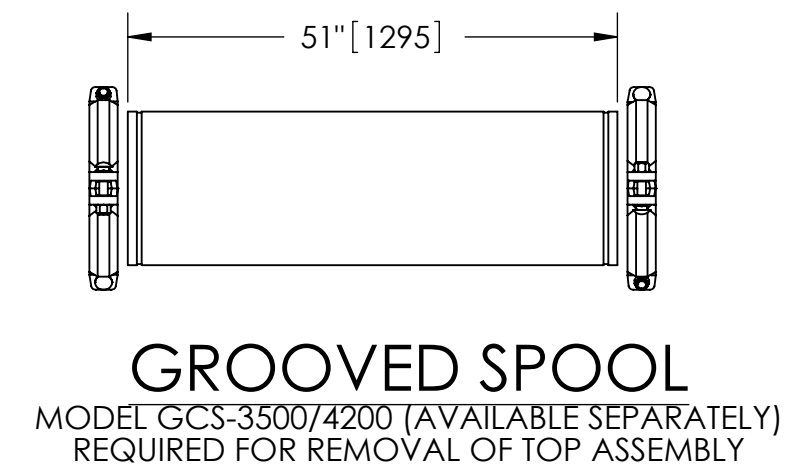

SUBMITTAL DRAWING

This drawing is submitted for spatial consideration only. Do not pre-plumb to these dimensions.

| | | | | | | | |
|--|--|------------------------------------|---------|---|------------------|---------------------------|--------|
| UNLESS OTHERWISE SPECIFIED: DIMENSIONS ARE IN: INCHES (mm) TOLERANCES ARE: FRACTIONS DECIMALS ANGLES ± 1/4" .XX ± .01 ± 1/4° .XXX ± .005 .XXXX ± .0005 | | ENGINEERED FOR: STANDARD | | CLAUDE LAVAL CORP. FRESNO, CALIFORNIA 93727 WWW.LAKOS.COM | | LAVAL UNDERGROUND SURVEYS | |
| DO NOT SCALE DRAWING | | APPROVALS | DATE | TITLE | | | |
| MATERIAL CLASS P-1 MILD CARBON STEEL | | DRAWN DLW | 1/27/06 | HTX-3500-V, SEPARATOR, 3500-6800 gpm, CARBON STEEL | | | |
| FINISH LAKOS BLACK | | ENGR β | 2/3/06 | SIZE C | MODEL NO. | DWG NO. 115290 | REV. C |
| | | WORK ORDER | QTY. | SCALE 1:20 | EST. WT. 4027 lb | SHEET 1 OF 1 | |

D

C

B

A

D

C

DWG NO.

115290

SHT

1

REV

C

A