

EXCEPT AS OTHERWISE PROVIDED BY CONTRACT, THIS DRAWING AND SPECIFICATIONS SHALL NOT BE REPRODUCED, COPIED OR USED AS THE BASIS FOR MANUFACTURE OR SALE OF MATTER DEPICTED HEREIN WITHOUT THE EXPRESSED WRITTEN PERMISSION OF THE CLAUDE LAVAL CORPORATION, OR ITS ASSIGNEES.

THIS DRAWING HAS BEEN GENERATED AND IS MAINTAINED BY A CAD SYSTEM. CHANGES SHALL ONLY BE INCORPORATED AS DIRECTED BY AN APPROVED ENGINEERING CHANGE ORDER (ECO). PAPER COPIES ARE UNCONTROLLED.

REVISION HISTORY				
ZONE	REV	DESCRIPTION	DATE	APPROVED

- NOTES:**
1. INLET IS 6" PIPE (125# ANSI FLANGED).
  2. OUTLET IS 4" PIPE (GROOVED).
  3. PURGE OUTLET IS 1-1/2" PIPE.
  4. MAXIMUM PRESSURE: 150 psi (10.3 bar).
  5. MAXIMUM TEMPERATURE: 100°F (37.8°C).
  6. SPECIFIED FLOWRATE OF 400 gpm (91 m³/hr).
  7. FINISH: AS ASSEMBLED.
  8. POWER REQUIREMENT: 460V, 3PH, 60Hz.
  9. NEMA 4X MOTOR STARTER ENCLOSURE WITH SAFETY DISCONNECT AND H.O.A. SWITCH.
  10. APPROXIMATE DRY WEIGHT: 1067 lbs (485 kg).
  11. INLET/OUTLET VALVE KIT, MODEL TCV-0400 RECOMMENDED.
  12. MINIMUM PIPE FROM TOWER BASIN TO TC SYSTEM IS 6" PIPE.
  13. FLOODED SUCTION REQUIRED.

- COMPONENT LIST:**
- ① ELECTRICAL CONTROL BOX 460V 60Hz W/120V TRANSFORMER.
  - ② SEPARATOR: HTX-0285-TC.
  - ③ PUMP: 15 HP CENTRIFUGAL, 3500 rpm, 460V, 60Hz.
  - ④ INLET/OUTLET PRESSURE GAUGES: 0-100 psi, GLYCERIN-FILLED.
  - ⑤ PURGE EQUIPMENT: SRV-816.
  - ⑥ DIFFERENTIAL PRESSURE INDICATOR: (AVAILABLE WITH DRY CONTACT-MODEL DHE-15-S. ORDER SEPARATELY).
  - ⑦ BASKET STRAINER.

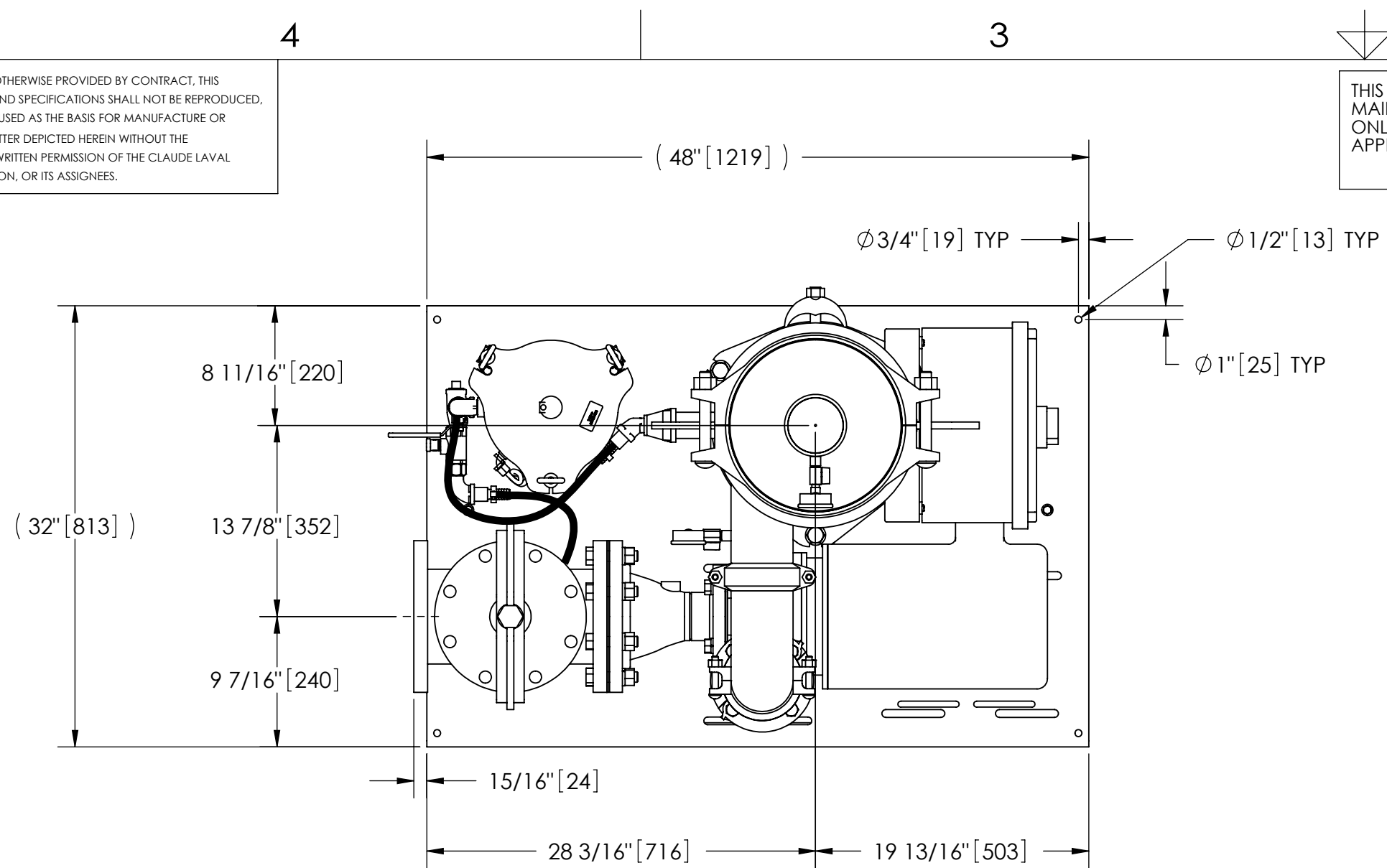

**TOP VIEW**

**SUBMITTAL DRAWING**

This drawing is submitted for spatial consideration only. Do not pre-plumb to these dimensions.

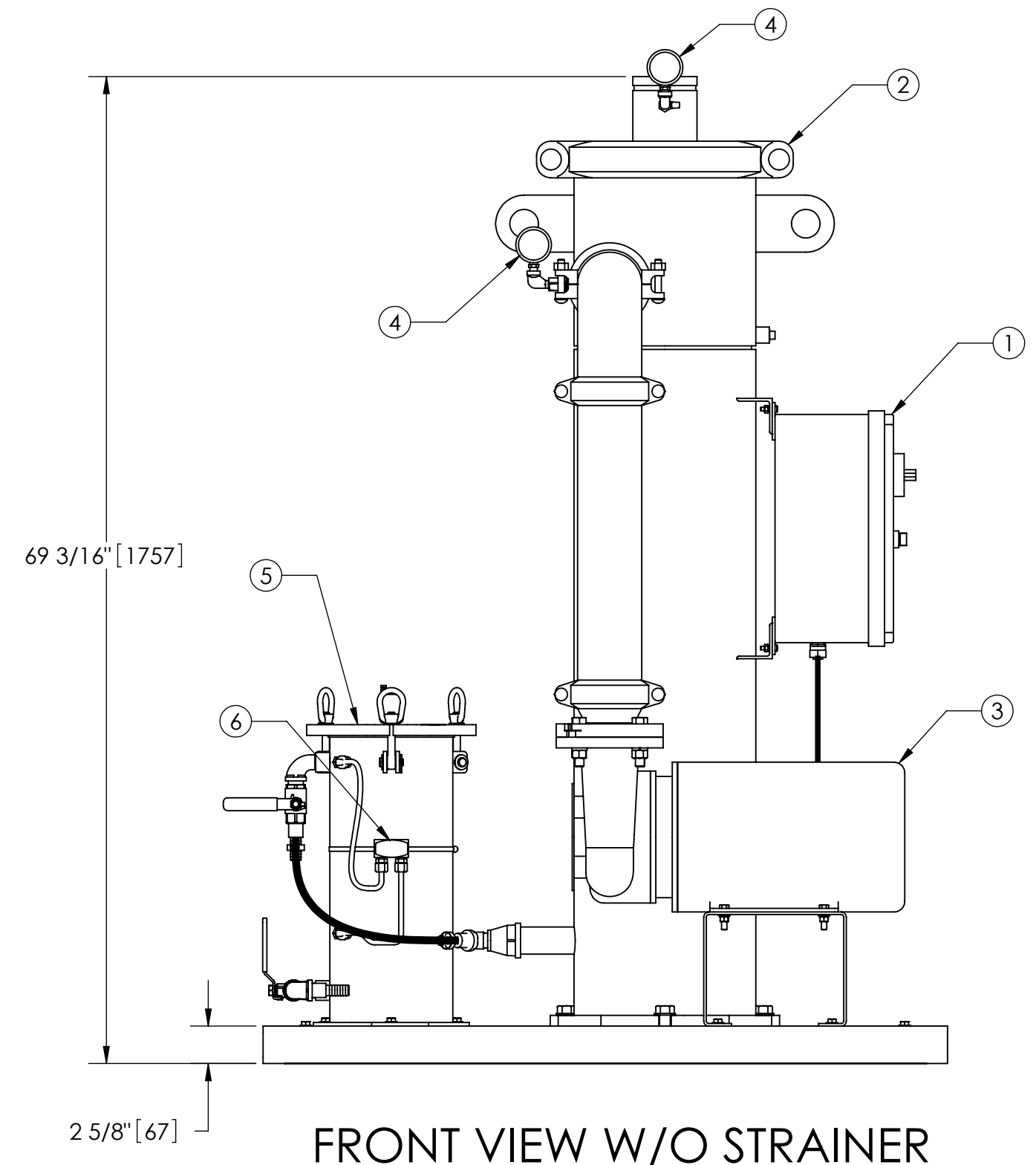

**FRONT VIEW W/O STRAINER**

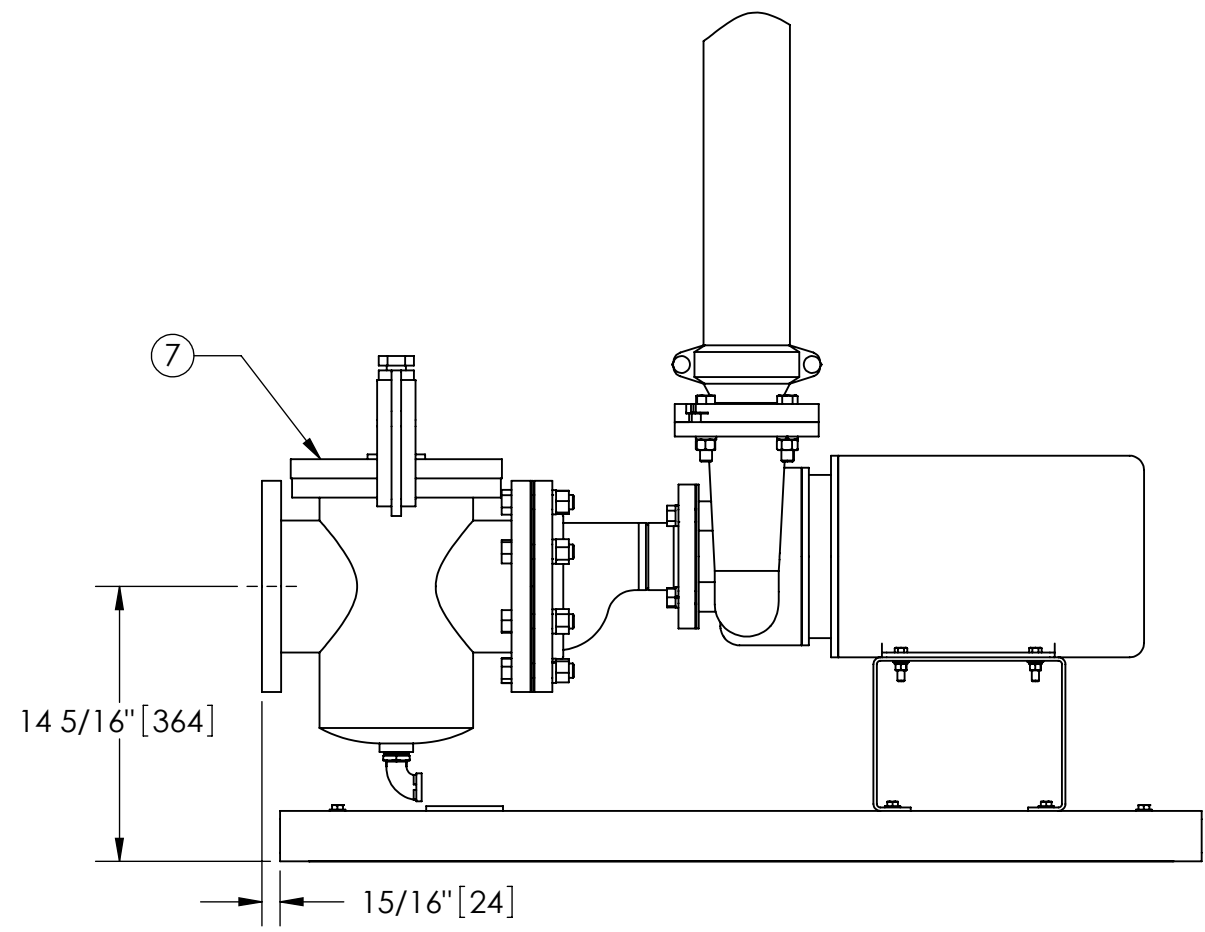

**FRONT VIEW PUMP & STRAINER**

UNLESS OTHERWISE SPECIFIED: DIMENSIONS ARE IN: INCHES (mm) TOLERANCES ARE: FRACTIONS DECIMALS ANGLES ± 1/2" .XX ± .01 ± 1/4" .XXX ± .005 .XXXX ± .0005	ENGINEERED FOR: <b>STANDARD</b>	CLAUDE LAVAL CORP. FRESNO, CALIFORNIA 93727 WWW.LAKOS.COM	LAVAL UNDERGROUND SURVEYS
	APPROVALS		
DO NOT SCALE DRAWING	DRAWN TOM C./HSK	5/17/05	TITLE
MATERIAL PER LAKOS SPEC	ENGR HSK	9/13/05	TCX-0400-SRV, TC SYSTEM, SWEEPER HTX-0285, 460V 60HZ DELUXE
FINISH AS ASSEMBLED	MFG -	-	SIZE MODEL NO. DWG NO.
	WORK ORDER	QTY.	C 1:10 115430
			EST. WT. 1067 lb SHEET 1 OF 1

DWG NO. 115430  
SHT 1  
REV. F