

EXCEPT AS OTHERWISE PROVIDED BY CONTRACT, THIS DRAWING AND SPECIFICATIONS SHALL NOT BE REPRODUCED, COPIED OR USED AS THE BASIS FOR MANUFACTURE OR SALE OF MATTER DEPICTED HEREIN WITHOUT THE EXPRESSED WRITTEN PERMISSION OF THE CLAUDE LAVAL CORPORATION, OR ITS ASSIGNEES.

REVISION HISTORY				
ZONE	REV	DESCRIPTION	DATE	APPROVED

THIS DRAWING HAS BEEN GENERATED AND IS MAINTAINED BY A CAD SYSTEM. CHANGES SHALL ONLY BE INCORPORATED AS DIRECTED BY AN APPROVED ENGINEERING CHANGE ORDER (ECO). PAPER COPIES ARE UNCONTROLLED.

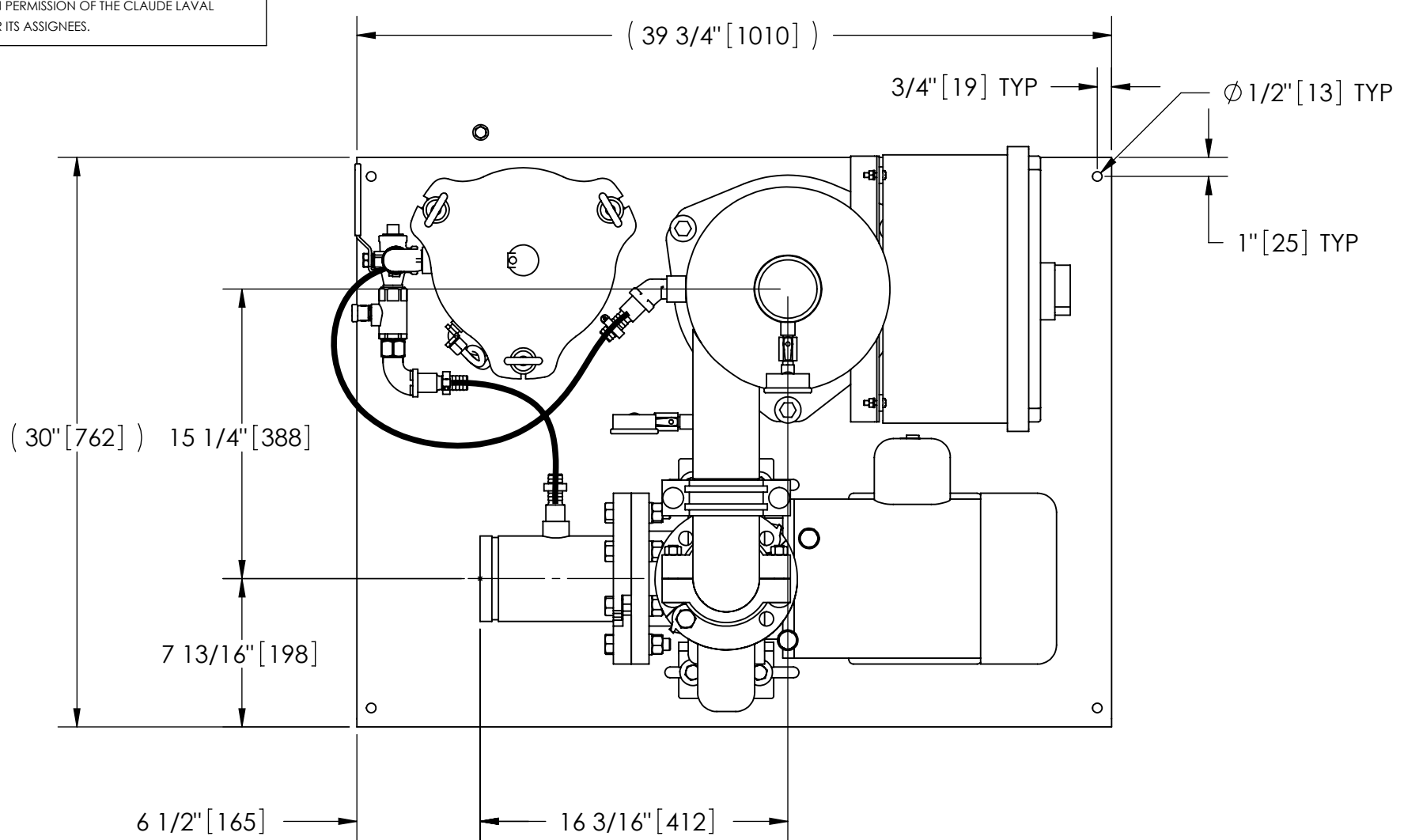

TOP VIEW

NOTES:

1. INLET IS 4" PIPE (GROOVED).
2. OUTLET IS 3" PIPE (GROOVED).
3. PURGE OUTLET IS 3/4" PIPE.
4. MAXIMUM PRESSURE: 150 psi (10.3 bar).
5. MAXIMUM TEMPERATURE: 100°F (37.8°C).
6. SPECIFIED FLOWRATE OF 200 gpm (45 m³/hr).
7. FINISH: AS ASSEMBLED.
8. POWER REQUIREMENT: 460V, 3PH, 60Hz.
9. NEMA 4X MOTOR STARTER ENCLOSURE WITH SAFETY DISCONNECT AND H.O.A. SWITCH.
10. APPROXIMATE DRY WEIGHT: 730 lbs (331 kg).
11. INLET/OUTLET VALVE KIT, MODEL TCV-0200 RECOMMENDED.
12. MINIMUM PIPE TO TB SYSTEM IS 4" PIPE.
13. FLOODED SUCTION REQUIRED.

COMPONENT LIST:

- ① ELECTRICAL CONTROL BOX 460V 60Hz W/120V TRANSFORMER.
- ② SEPARATOR: ILB-0300-TC.
- ③ PUMP: 5 HP CENTRIFUGAL, 1750 rpm, 460V, 60Hz.
- ④ INLET/OUTLET PRESSURE GAUGES: 0-100 psi, GLYCERIN-FILLED.
- ⑤ PURGE EQUIPMENT: SRV-816.
- ⑥ DIFFERENTIAL PRESSURE INDICATOR: (AVAILABLE WITH DRY DRY CONTACT-MODEL DHE-15-S. ORDER SEPARATELY).

SUBMITTAL DRAWING

This drawing is submitted for spatial consideration only. Do not pre-plumb to these dimensions.

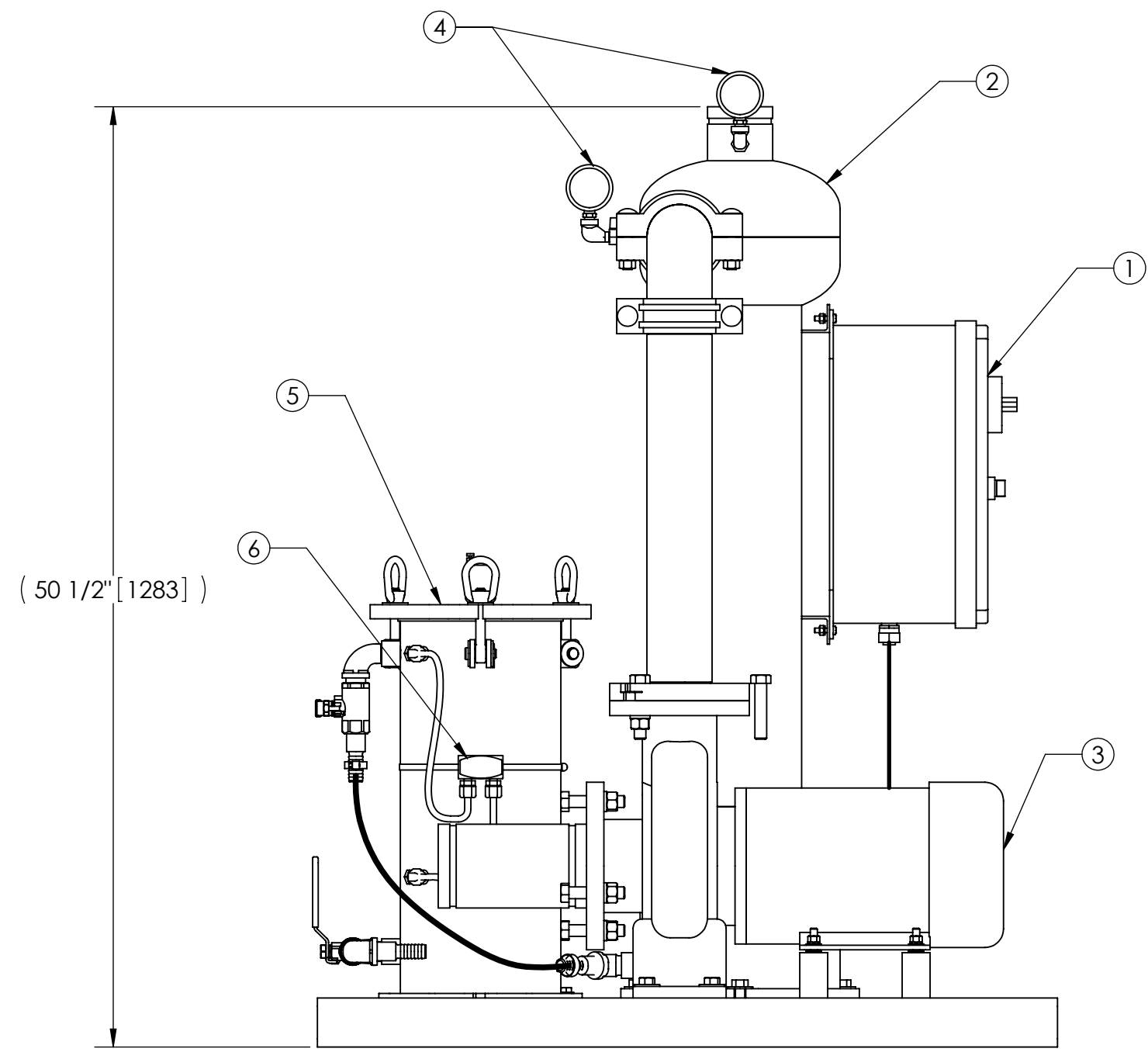

FRONT VIEW W/O SPOOL

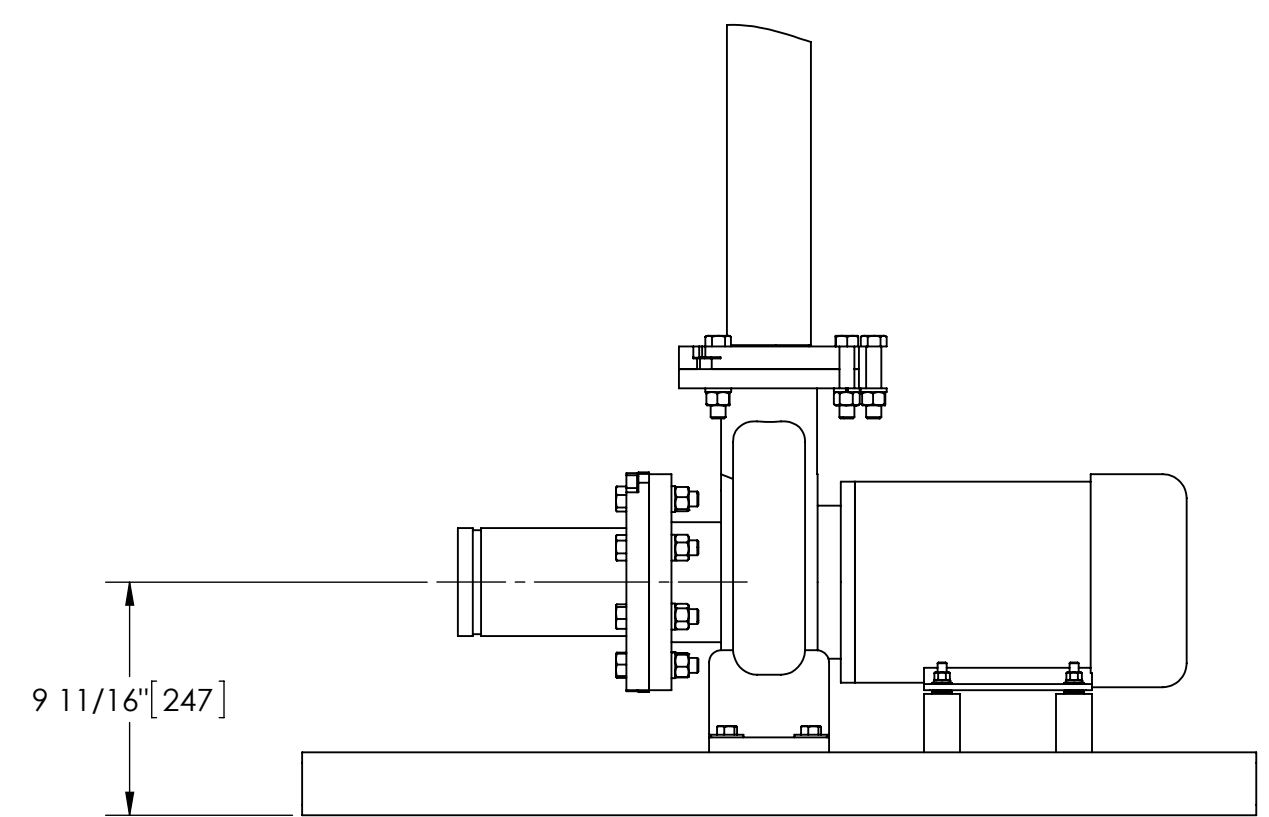

FRONT VIEW PUMP & SPOOL

UNLESS OTHERWISE SPECIFIED: DIMENSIONS ARE IN: INCHES (mm) TOLERANCES ARE: FRACTIONS    DECIMALS    ANGLES ± 1/2"    .XX ± .01    ± 1/4° .XXX ± .005 .XXXX ± .0005		ENGINEERED FOR: <b>STANDARD</b>		CLAUDE LAVAL CORP. FRESNO, CALIFORNIA 93727 WWW.LAKOS.COM		LAVAL UNDERGROUND SURVEYS	
DO NOT SCALE DRAWING	APPROVALS	DATE	TITLE				
MATERIAL PER LAKOS SPEC	DRAWN SGF/DLW	4/29/05	TBI-0200-SRV, TC SYSTEM, SIDESTREAM ILB-0300, 3/60/460V				
FINISH AS ASSEMBLED	ENGR HSK	6/21/05	SIZE C	MODEL NO.	DWG NO. <b>115455</b>	REV. F	
	WORK ORDER	QTY.	SCALE 1:8	EST. WT. 730 lb	SHEET 1 OF 1		

DWG. NO. 115455 SHEET REV. F