

EXCEPT AS OTHERWISE PROVIDED BY CONTRACT, THIS DRAWING AND SPECIFICATIONS SHALL NOT BE REPRODUCED, COPIED OR USED AS THE BASIS FOR MANUFACTURE OR SALE OF MATTER DEPICTED HEREIN WITHOUT THE EXPRESSED WRITTEN PERMISSION OF THE CLAUDE LAVAL CORPORATION, OR ITS ASSIGNEES.

NOTES:

1. INLET & OUTLET FLANGES ARE 6" 150# RF PER ANSI B165 REQUIRING 8X Ø5/8" BOLTS (BOLTS AND GASKETS NOT INCLUDED).
2. MAXIMUM PRESSURE: 250 psi (17.24 bar).
3. MAXIMUM TEMPERATURE: 230°F (110°C).
4. PRESSURE LOSS: 5-18 psid (.34-1.24 bar) AT RATED FLOW.
5. RATED FLOW: 425-820 gpm (96.5-186.2 m³/hr).
6. APPROXIMATE DRY WEIGHT: 1122 lbs (509 kg).
7. FINISH: LAKOS BLUE (EXTERIOR ONLY).

REVISIONS				
ECN	REV.	DESCRIPTION	DATE	APPROVED

SUBMITTAL DRAWING

This drawing is submitted for spatial consideration only. Do not pre-plumb to these dimensions.

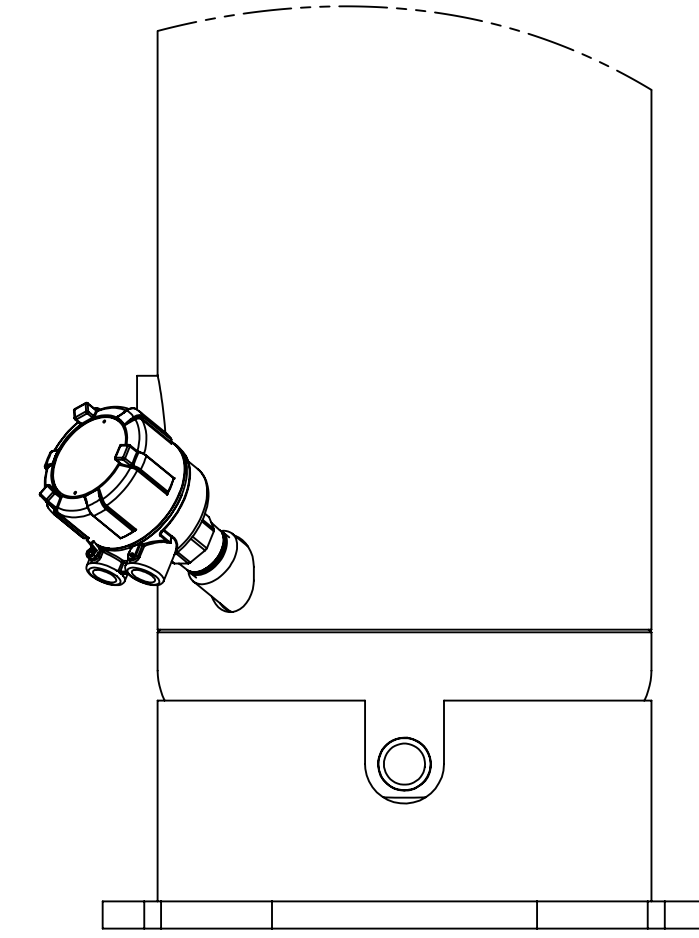
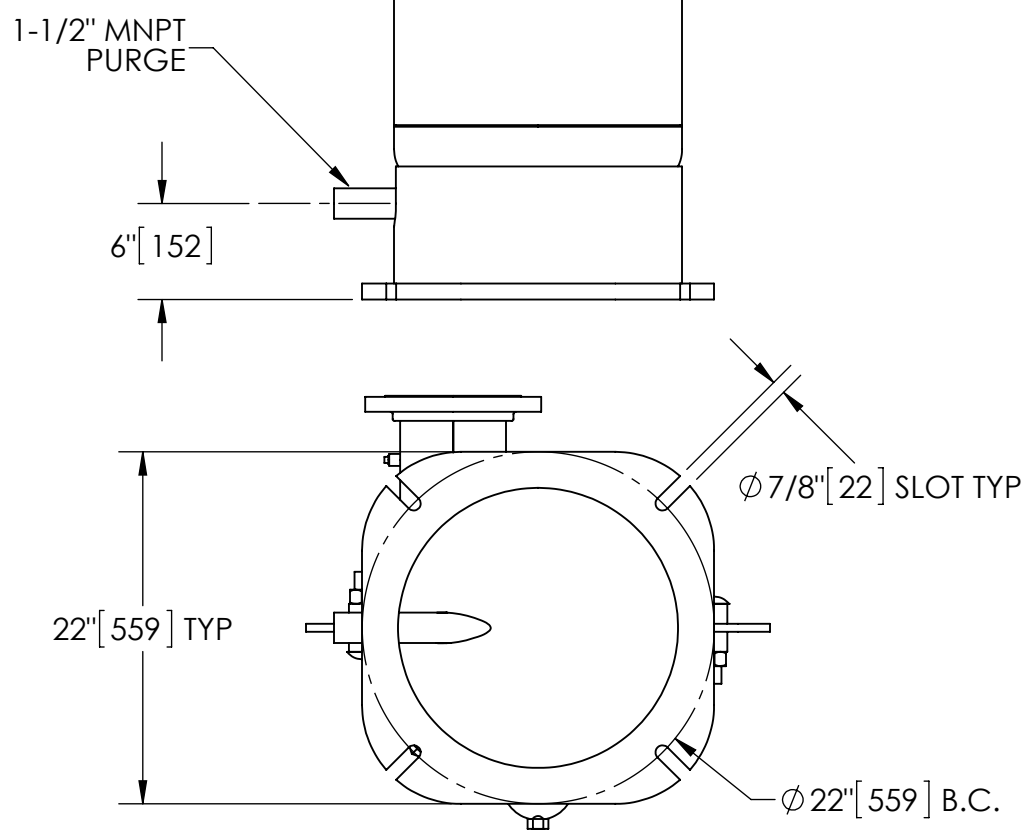
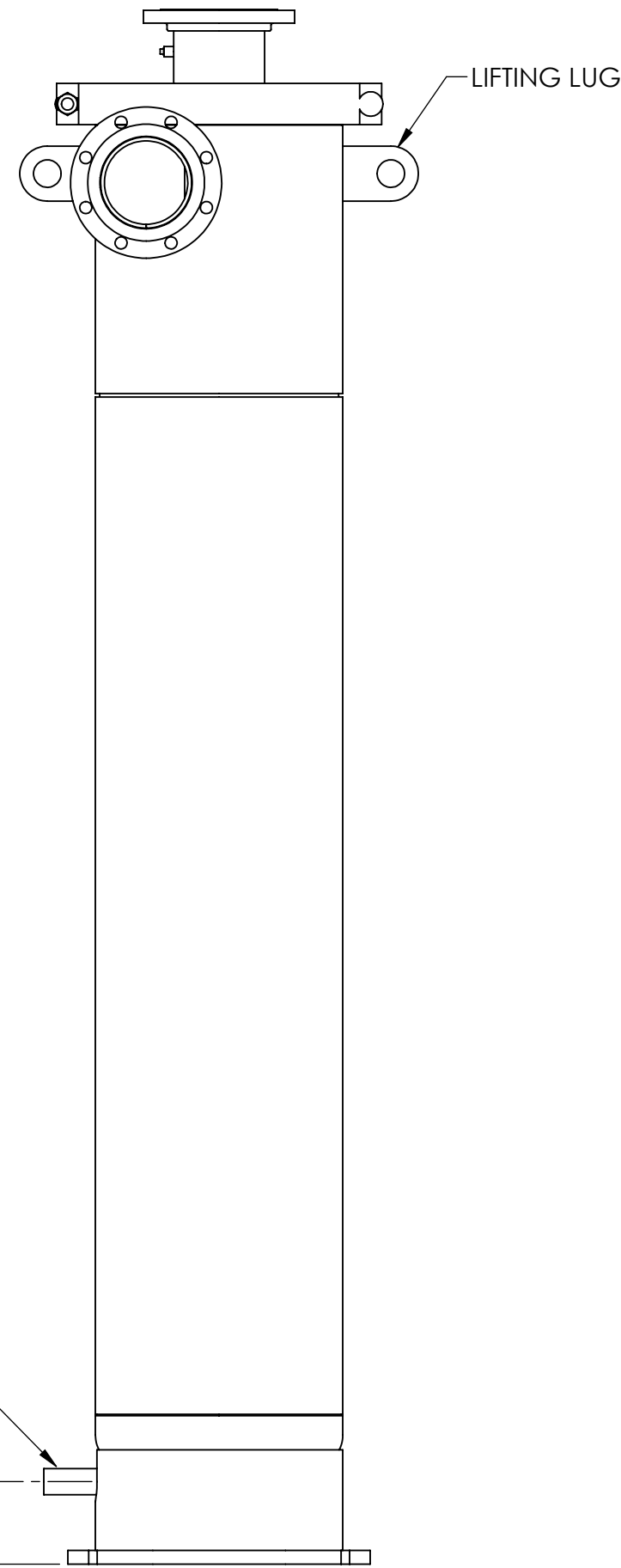
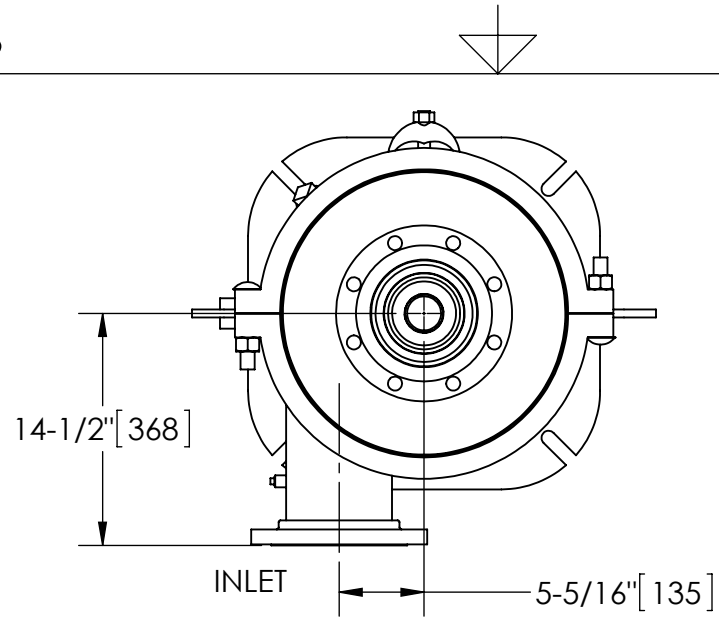
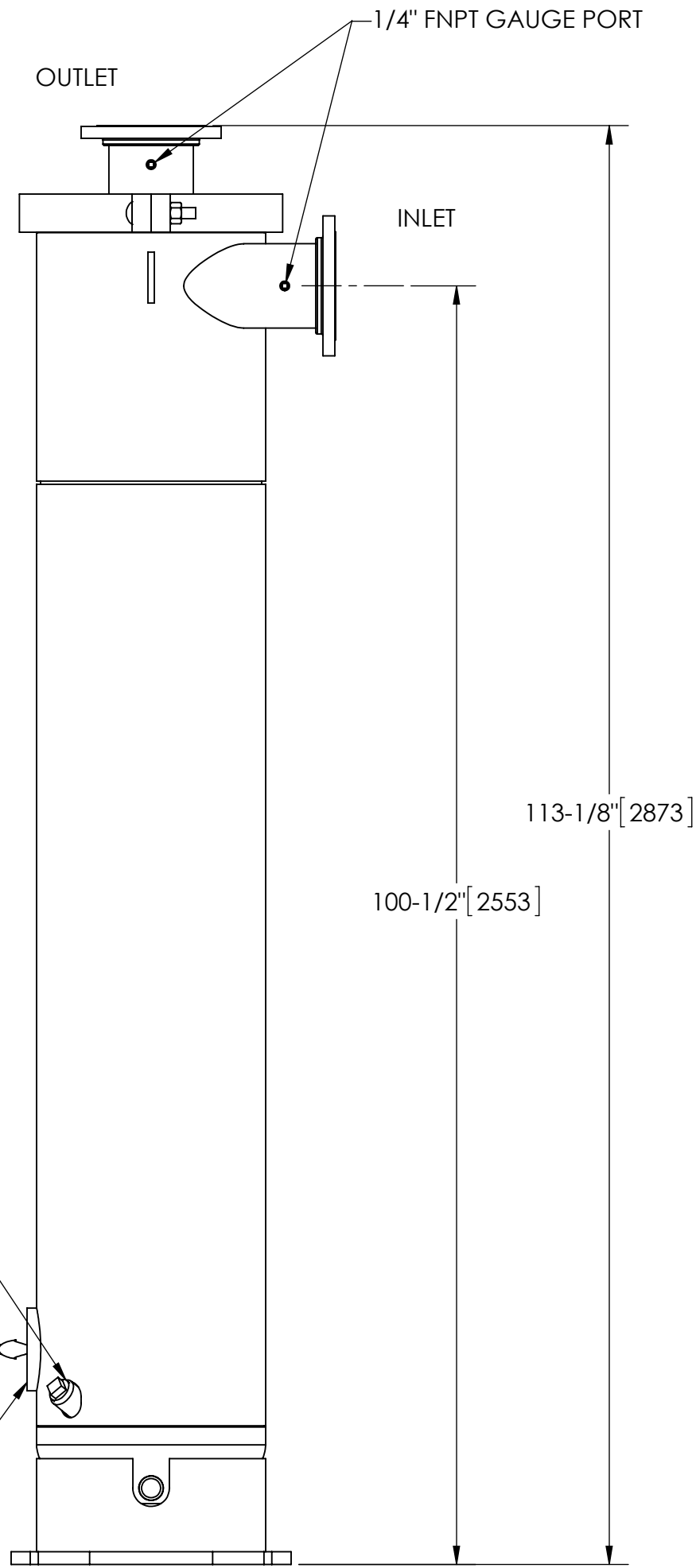

OPTIONAL SMART PURGE
UNIT SHOWN WITH OPTIONAL PURGE SENSOR ASSEMBLY INSTALLED (AVAILABLE SEPARATELY)

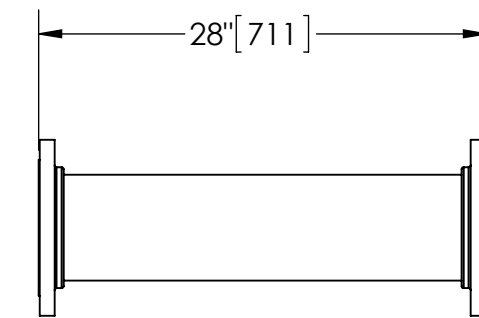

OPTIONAL FLANGED SPOOL
MODEL FS-06 (AVAILABLE SEPARATELY)
REQUIRED FOR REMOVAL OF TOP ASSEMBLY

SMART PURGE MOUNT
CLEANOUT HANDHOLE

THIS DRAWING HAS BEEN GENERATED AND IS MAINTAINED BY A CAD SYSTEM. CHANGES SHALL ONLY BE INCORPORATED AS DIRECTED BY AN APPROVED ENGINEERING CHANGE ORDER (ECO). PAPER COPIES ARE UNCONTROLLED.

UNLESS OTHERWISE SPECIFIED: DIMENSIONS ARE IN: INCHES (mm) TOLERANCES ARE: FRACTIONS DECIMALS ANGLES ± 1/2" .XX ± .01 ± 1/4° .XXX ± .005 .XXXX ± .0005	ENGINEERED FOR: STANDARD	
	APPROVALS	DATE
	DRAWN Cag	10/2/14
	ENGR -	-
MATERIAL CLASS P-1 MILD CARBON STEEL	ENGR -	-
FINISH LAKOS BLUE	MFG -	-
	WORK ORDER	QTY.

LAKOS.		CLAUDE LAVAL CORP. FRESNO, CALIFORNIA 93727 WWW.LAKOS.COM	
TITLE eJPX-0425-V, SEPERATOR 0425 eJPX VERTICAL, CARBON STEEL			
SIZE C	MODEL NO.	DWG NO. 137168	REV. 01
SCALE 1:12	EST. WT. 1122 lb	SHEET 1 OF 1	

DWG. NO. 137168
SHEET 1
REV. 01