

EXCEPT AS OTHERWISE PROVIDED BY CONTRACT, THIS DRAWING AND SPECIFICATIONS SHALL NOT BE REPRODUCED, COPIED OR USED AS THE BASIS FOR MANUFACTURE OR SALE OF MATTER DEPICTED HEREIN WITHOUT THE EXPRESSED WRITTEN PERMISSION OF THE CLAUDE LAVAL CORPORATION, OR ITS ASSIGNEES.

THIS DRAWING HAS BEEN GENERATED AND IS MAINTAINED BY A CAD SYSTEM. CHANGES SHALL ONLY BE INCORPORATED AS DIRECTED BY AN APPROVED ENGINEERING CHANGE ORDER (ECO). PAPER COPIES ARE UNCONTROLLED.

REVISIONS				
ECN	REV.	DESCRIPTION	DATE	APPROVED

NOTES:

1. INLET & OUTLET ARE 2" MNPT PIPE.
2. MAXIMUM PRESSURE: 150 psi (10.3 bar).
3. MAXIMUM TEMPERATURE: 180°F (82.2°C).
4. PRESSURE LOSS: 3-12 psid (.2-.8 bar) AT RATED FLOW.
5. RATED FLOW: 65-108 gpm (14.5-24.5 m³/hr).
6. APPROXIMATE DRY WEIGHT: 49 lbs (22 kg).
7. FINISH: GLASS BLAST (EXTERIOR ONLY).

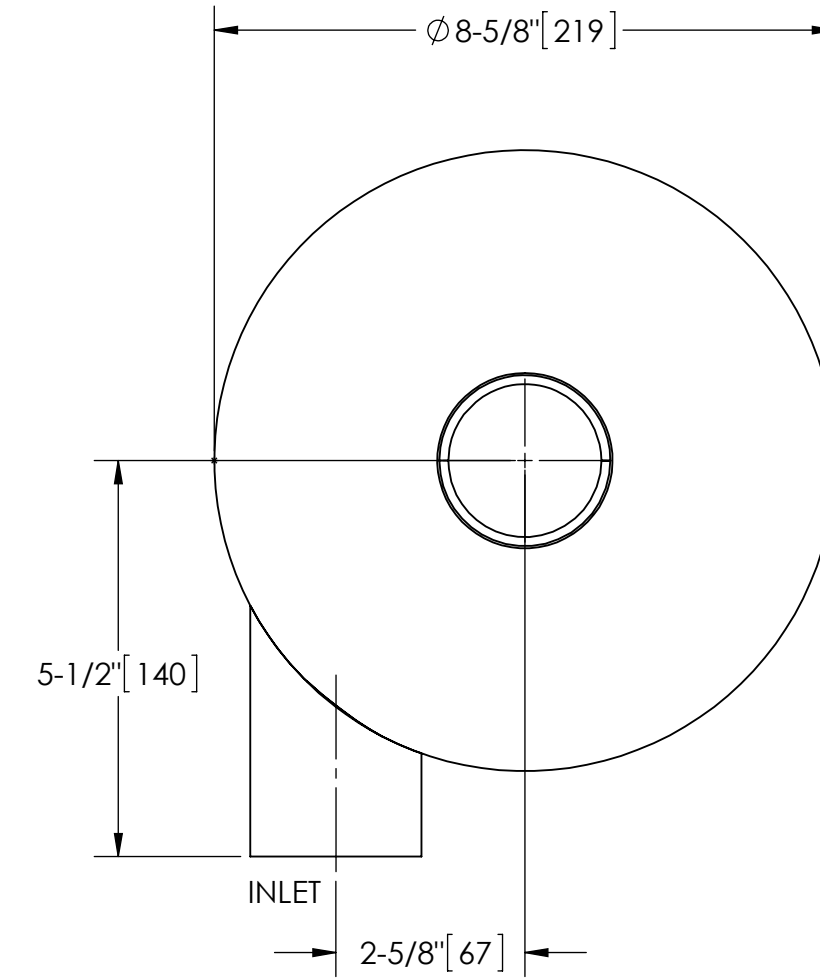
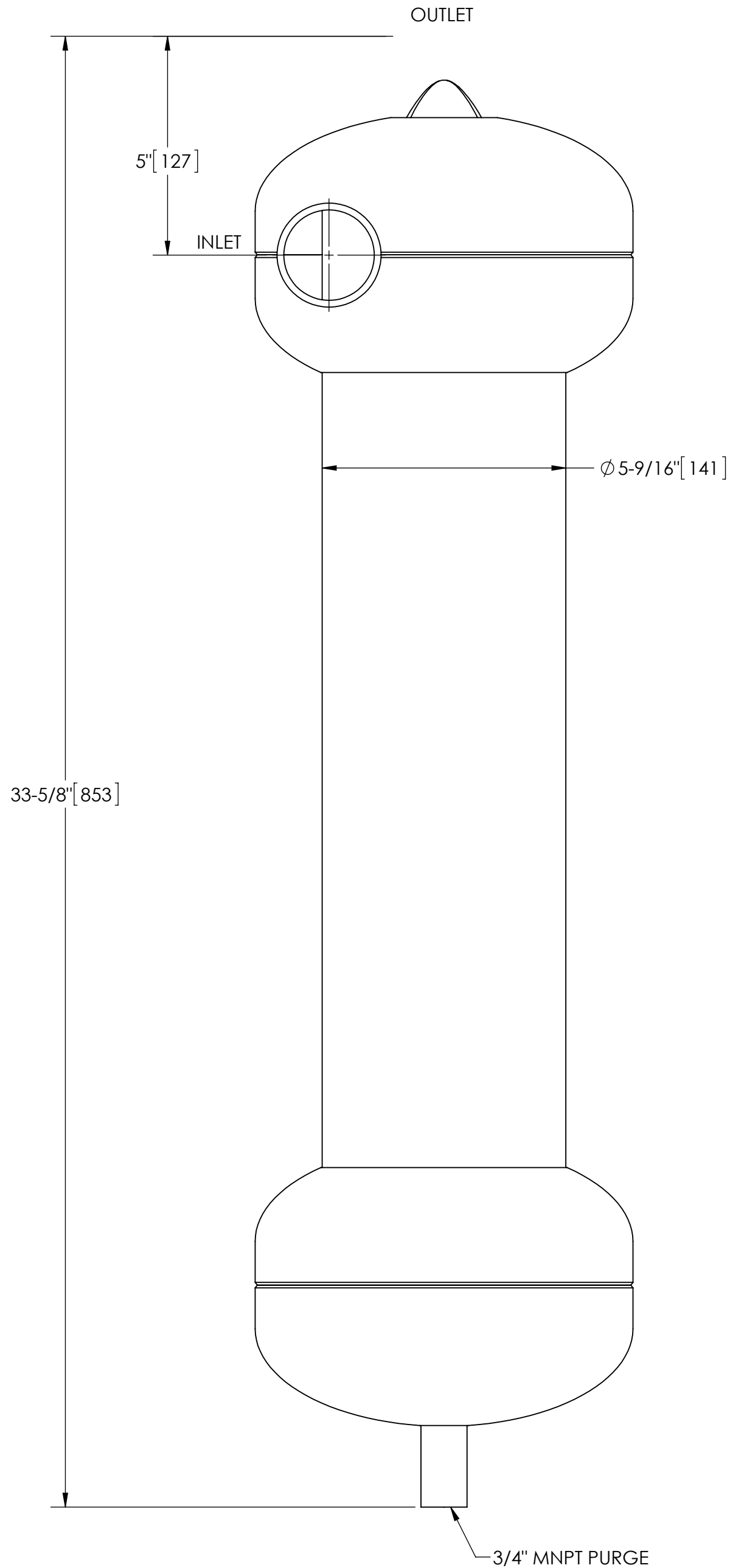

TOP VIEW

**SUBMITTAL DRAWING**

This drawing is submitted for spatial consideration only. Do not pre-plumb to these dimensions.

UNLESS OTHERWISE SPECIFIED: DIMENSIONS ARE IN: INCHES (mm) TOLERANCES ARE: FRACTIONS    DECIMALS    ANGLES ± 1"    .XX ± .01    ± 1/4° .XXX ± .005 .XXXX ± .0005	ENGINEERED FOR: <b>STANDARD</b>		CLAUDE LAVAL CORP. FRESNO, CALIFORNIA 93727 WWW.LAKOS.COM		LAVAL UNDERGROUND SURVEYS
	DO NOT SCALE DRAWING	APPROVALS	DATE	TITLE	
MATERIAL TYPE 316L STAINLESS STEEL	DRAWN AMF	8/10/10	ILS-0200, SEPARATOR, 65-108 gpm, 316L SS		
FINISH GLASS BLAST	ENGR JBI	10/13/09	SIZE C	MODEL NO.	DWG NO. 100299
	WORK ORDER	QTY.	SCALE 3:8	EST. WT. 47 lb	SHEET 1 OF 1

DWG NO. 100299  
SHEET 1  
REV. C