

EXCEPT AS OTHERWISE PROVIDED BY CONTRACT, THIS DRAWING AND SPECIFICATIONS SHALL NOT BE REPRODUCED, COPIED OR USED AS THE BASIS FOR MANUFACTURE OR SALE OF MATTER DEPICTED HEREIN WITHOUT THE EXPRESSED WRITTEN PERMISSION OF THE CLAUDE LAVAL CORPORATION, OR ITS ASSIGNEES.

THIS DRAWING HAS BEEN GENERATED AND IS MAINTAINED BY A CAD SYSTEM. CHANGES SHALL ONLY BE INCORPORATED AS DIRECTED BY AN APPROVED ENGINEERING CHANGE ORDER (ECO). PAPER COPIES ARE UNCONTROLLED.

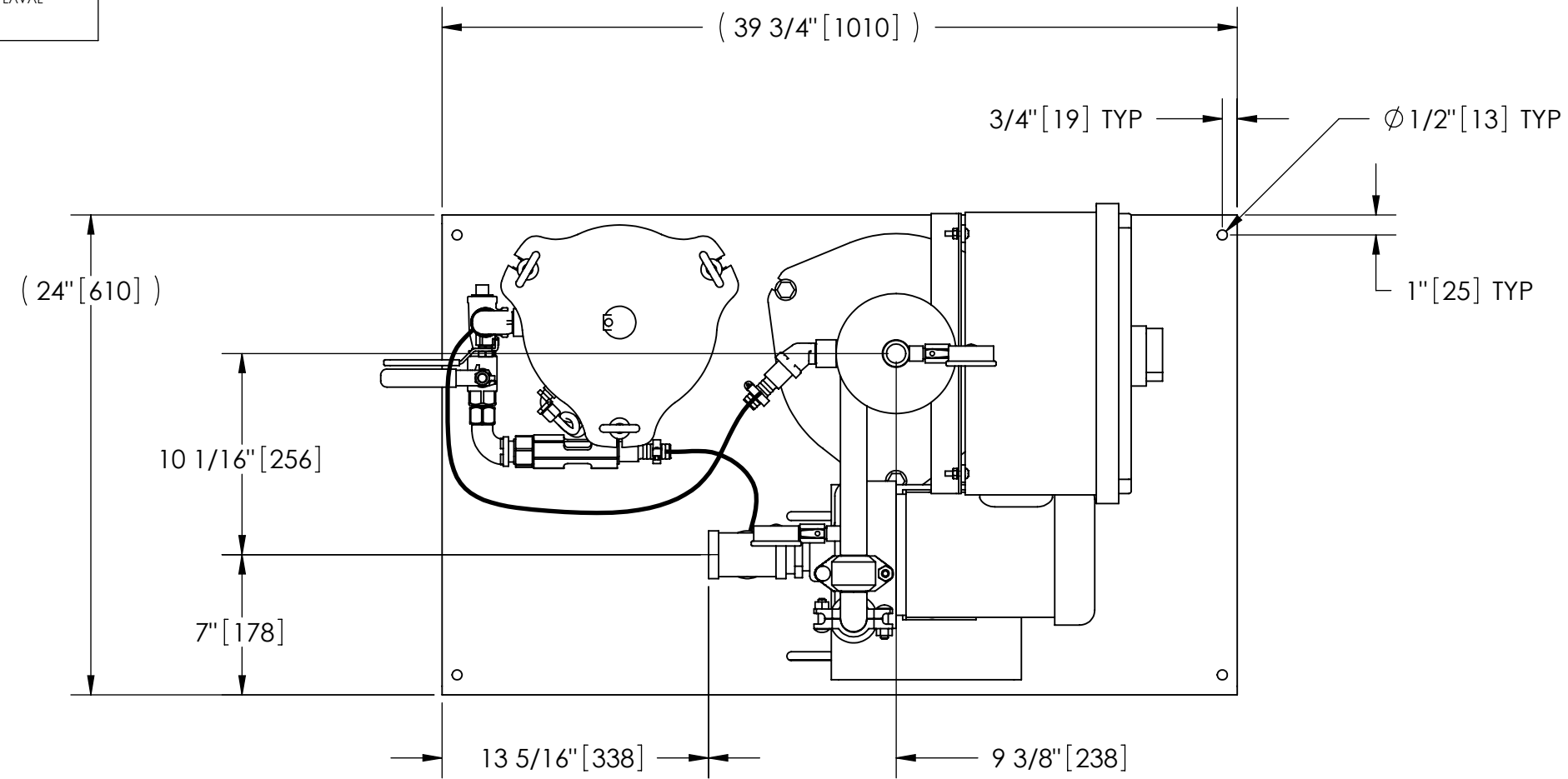

TOP VIEW

NOTES:

1. INLET IS 1-1/2" PIPE (FNPT).
2. OUTLET IS 1" PIPE (GROOVED).
3. PURGE OUTLET IS 3/4" PIPE.
4. MAXIMUM PRESSURE: 150 psi (10.3 bar).
5. MAXIMUM TEMPERATURE: 100°F (37.8°C).
6. SPECIFIED FLOWRATE OF 30 gpm (6.8 m³/hr).
7. FINISH: AS ASSEMBLED.
8. POWER REQUIREMENT: 460V, 3PH, 60Hz.
9. NEMA 4X MOTOR STARTER ENCLOSURE WITH SAFETY DISCONNECT AND H.O.A. SWITCH.
10. APPROXIMATE DRY WEIGHT: 307 lbs (139 kg).
11. INLET/OUTLET VALVE KIT, MODEL TCV-0030 RECOMMENDED.
12. MINIMUM PIPE FROM TOWER BASIN TO TC SYSTEM IS 2" PIPE.
13. FLOODED SUCTION REQUIRED.

COMPONENT LIST:

- ① ELECTRICAL CONTROL BOX 460V 60Hz W/120V TRANSFORMER.
- ② SEPARATOR: ILB-0100-TC.
- ③ PUMP: 1 HP CENTRIFUGAL, 3500 rpm, 460V, 60Hz.
- ④ INLET/OUTLET PRESSURE GAUGES: 0-100 psi, GLYCERIN-FILLED.
- ⑤ PURGE EQUIPMENT: SRV-816.
- ⑥ DIFFERENTIAL PRESSURE INDICATOR: (AVAILABLE WITH DRY DRY CONTACT-MODEL DHE-15-S. ORDER SEPARATELY).

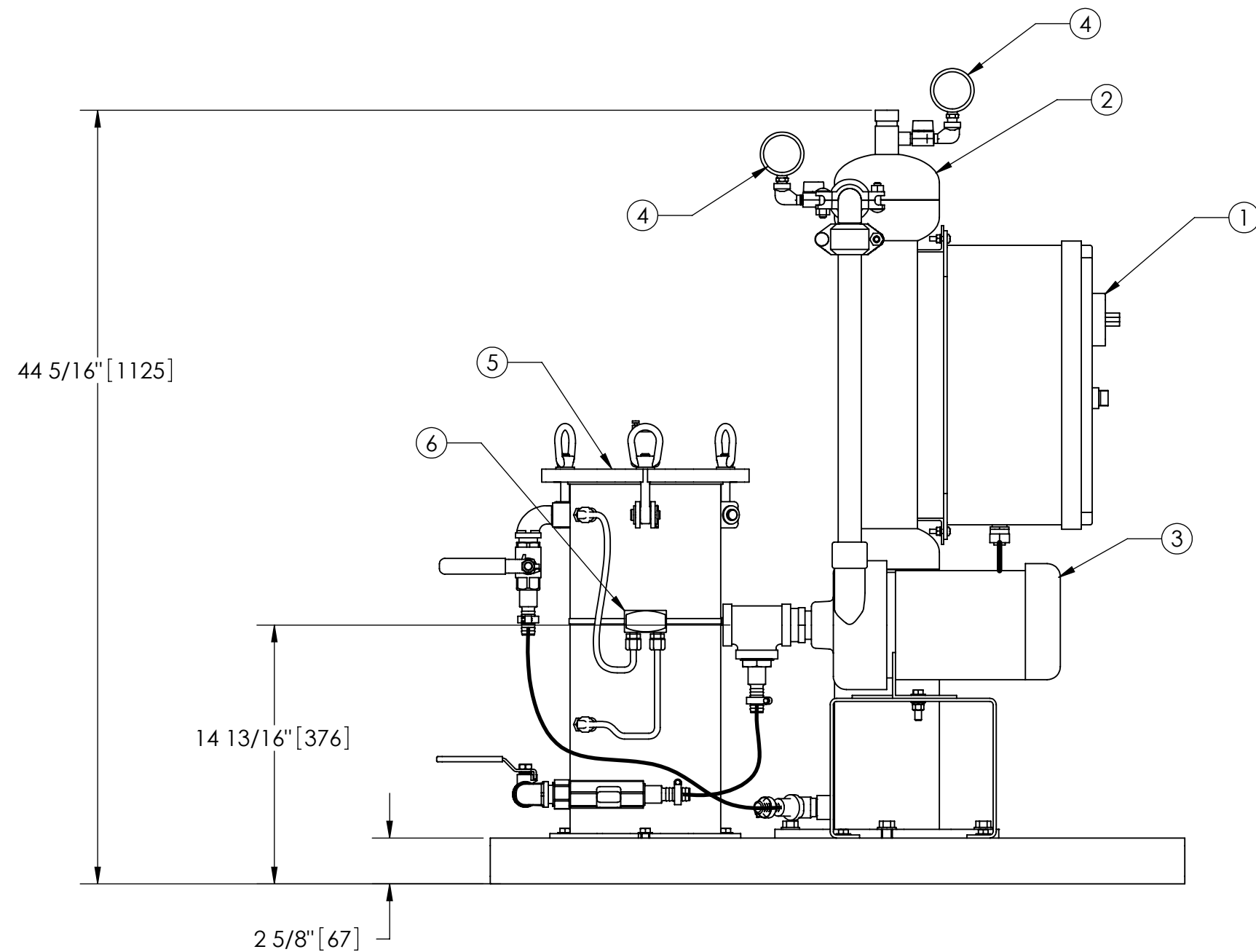

FRONT VIEW

SUBMITTAL DRAWING

This drawing is submitted for spatial consideration only. Do not pre-plumb to these dimensions.

UNLESS OTHERWISE SPECIFIED: DIMENSIONS ARE IN: INCHES (mm) TOLERANCES ARE: FRACTIONS DECIMALS ANGLES ± 1/2" .XX ± .01 ± 1/4° .XXX ± .005 .XXXX ± .0005		ENGINEERED FOR: STANDARD		LAKOS. CLAUDE LAVAL CORP. FRESNO, CALIFORNIA 93727 WWW.LAKOS.COM		LAKOS UNDERGROUND SURVEYS	
DO NOT SCALE DRAWING		APPROVALS	DATE	TITLE			
MATERIAL PER LAKOS SPEC		DRAWN ADJ	5/18/09	TBI-0030-SRV, TC SYSTEM, SIDESTREAM ILB-0100, 3/60/460V			
FINISH AS ASSEMBLED		ENGR ADJ	5/18/09	SIZE C	MODEL NO.	DWG NO. 128977	REV. -
		WORK ORDER	QTY.	SCALE 1:8	EST. WT. 307 lb	SHEET 1 OF 1	

DWG. NO. 128977 SHEET REV. -