

EXCEPT AS OTHERWISE PROVIDED BY CONTRACT, THIS DRAWING AND SPECIFICATIONS SHALL NOT BE REPRODUCED, COPIED OR USED AS THE BASIS FOR MANUFACTURE OR SALE OF MATTER DEPICTED HEREIN WITHOUT THE EXPRESSED WRITTEN PERMISSION OF THE CLAUDE LAVAL CORPORATION, OR ITS ASSIGNEES.

THIS DRAWING HAS BEEN GENERATED AND IS MAINTAINED BY A CAD SYSTEM. CHANGES SHALL ONLY BE INCORPORATED AS DIRECTED BY AN APPROVED ENGINEERING CHANGE ORDER (ECO). PAPER COPIES ARE UNCONTROLLED.

REVISION HISTORY				
ZONE	REV	DESCRIPTION	DATE	APPROVED

- NOTES:**
- INLET IS 4" PIPE (125# ANSI FLANGED).
 - OUTLET IS 3" PIPE (GROOVED).
 - PURGE OUTLET IS 3/4" PIPE.
 - MAXIMUM PRESSURE: 150 psi (10.3 bar).
 - MAX FLUID OPERATING TEMPERATURE: 100°F (37.8°C).
 - SPECIFIED FLOW RATES:
BASIN SWEEPING- 210 gpm (48 m³/hr).
SIDE STREAM & CLOSED LOOP- 250 gpm (57 m³/hr).
 - FINISH: AS ASSEMBLED.
 - POWER REQUIREMENT: 208V/230V/460V, 3PH, 60Hz. (CUSTOMER SPECIFIED)
 - NEMA 4X MOTOR STARTER ENCLOSURE WITH SAFETY DISCONNECT AND H.O.A. SWITCH.
 - APPROXIMATE DRY WEIGHT: 934 lbs (423 kg).
 - INLET/OUTLET VALVE KIT RECOMMENDED: SEE FACTORY.
 - MINIMUM PIPE FROM TOWER BASIN TO TC SYSTEM IS 4" PIPE.
 - FLOODED SUCTION REQUIRED.

- COMPONENT LIST:**
- ELECTRICAL CONTROL BOX 208V/230V/460V, 60Hz W/120V TRANSFORMER.
 - SEPARATOR: eHTX-0090-V.
 - PUMP: 7.5 HP CENTRIFUGAL, 1750 rpm, 208V/230V/460V, 60Hz.
 - INLET/OUTLET PRESSURE GAUGES: 0-160 psi, GLYCERIN-FILLED.
 - PURGE EQUIPMENT: SRV-833.
 - STRAINER, SUCTION DIFFUSER.

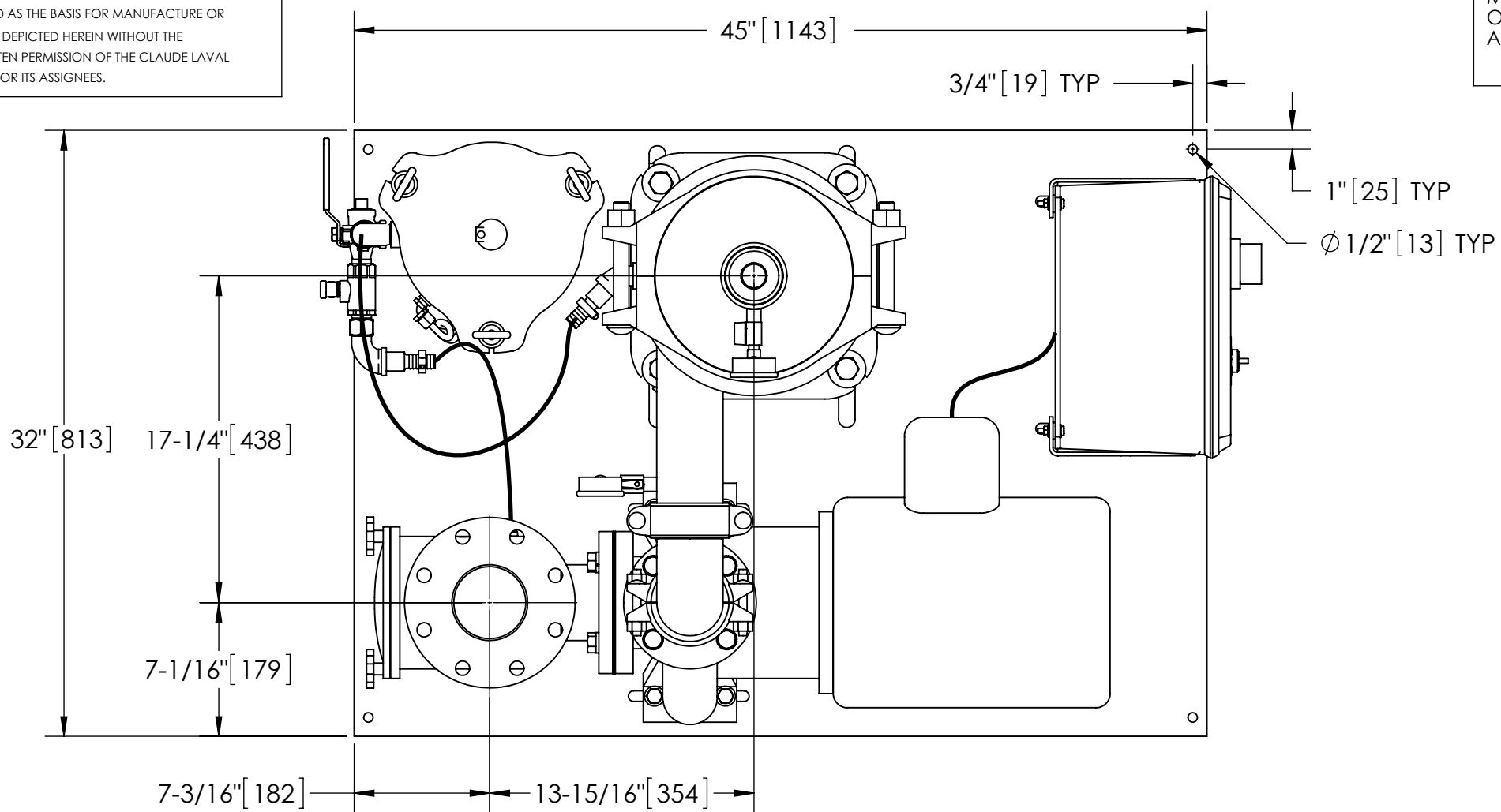

TOP VIEW

SUBMITTAL DRAWING

This drawing is submitted for spatial consideration only. Do not pre-plumb to these dimensions.

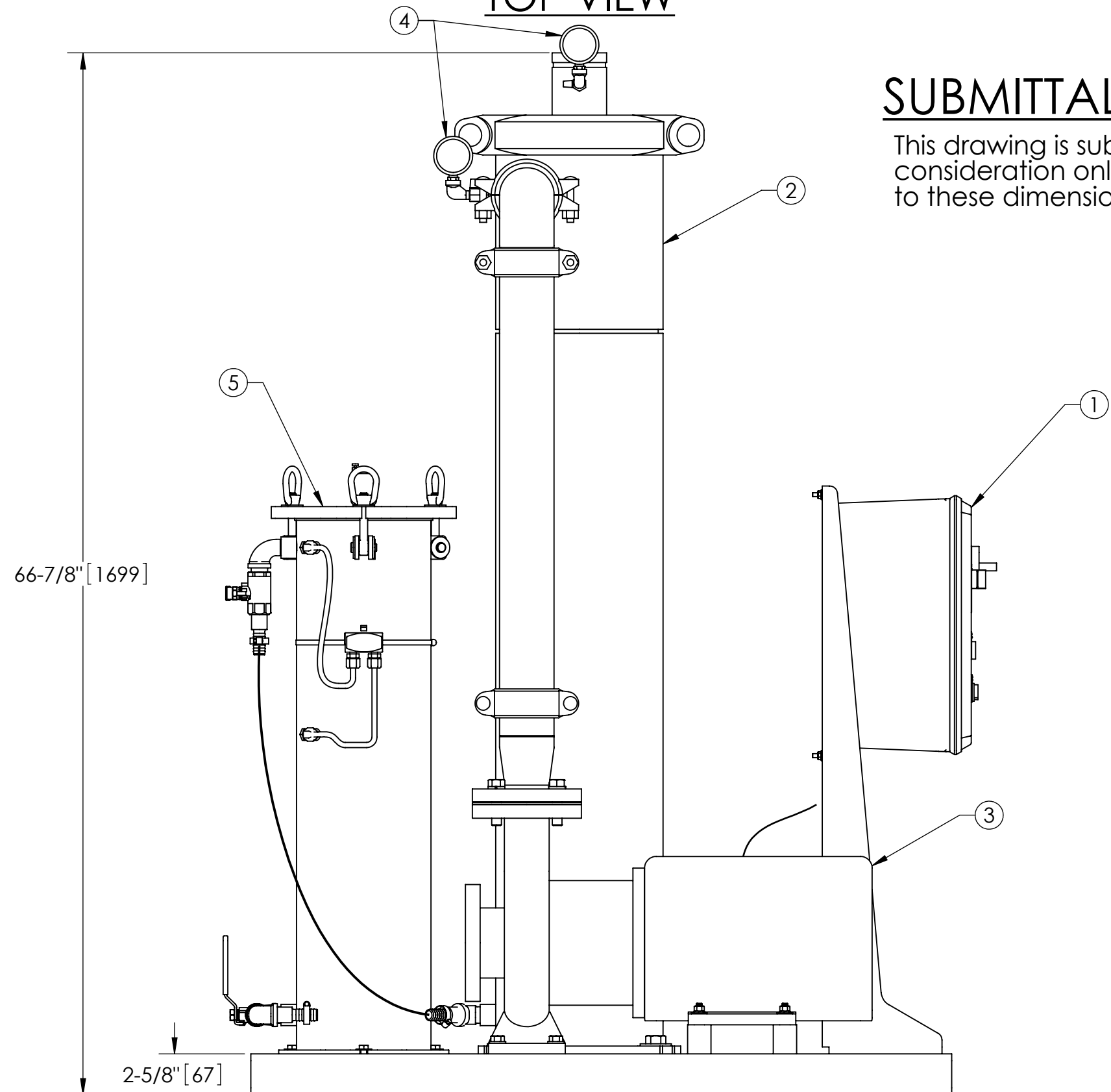

FRONT VIEW W/O STRAINER

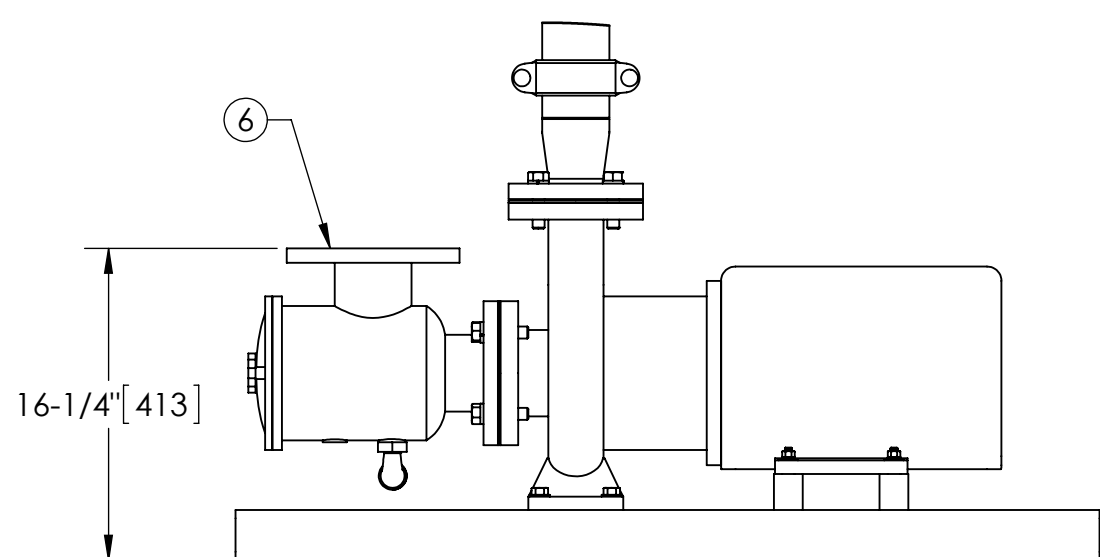

FRONT VIEW PUMP & STRAINER

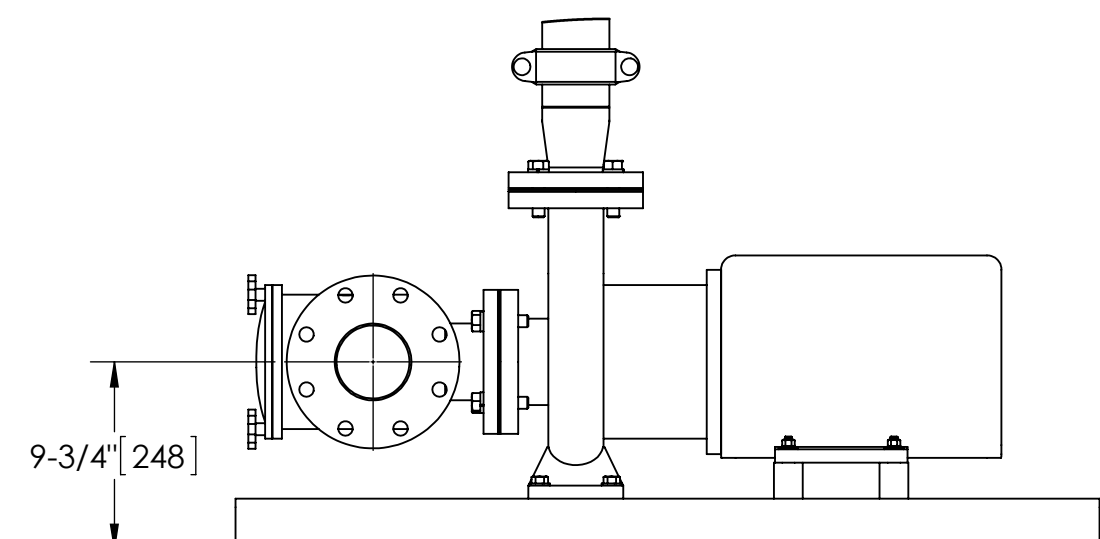

FRONT VIEW ROTATED STRAINER (OPTIONAL)

UNLESS OTHERWISE SPECIFIED: DIMENSIONS ARE IN: INCHES (mm) TOLERANCES ARE: FRACTIONS DECIMALS ANGLES ± 1/2" .XX ± .01 ± 1/4" .XXX ± .005 .XXXX ± .0005		ENGINEERED FOR: STANDARD		LAKOS CLAUDE LAVAL CORP. FRESNO, CALIFORNIA 93727 WWW.LAKOS.COM	
DO NOT SCALE DRAWING	APPROVALS	DATE	TITLE eTCX-0210-SRV, TC SYSTEM HI EFF SWEEPER eHTX-0090, 3/60/208, 230, 460V		
MATERIAL PER LAKOS SPEC	ENGR	-	SIZE C	MODEL NO.	DWG NO. 135140
FINISH AS ASSEMBLED	MFG	-	SCALE 1:8	EST. WT. 934 lb	REV. C
	WORK ORDER	QTY.	SHEET 1 OF 2		

DWG. NO. 135140 SH. REV. C