

EXCEPT AS OTHERWISE PROVIDED BY CONTRACT, THIS DRAWING AND SPECIFICATIONS SHALL NOT BE REPRODUCED, COPIED OR USED AS THE BASIS FOR MANUFACTURE OR SALE OF MATTER DEPICTED HEREIN WITHOUT THE EXPRESSED WRITTEN PERMISSION OF THE CLAUDE LAVAL CORPORATION, OR ITS ASSIGNEES.

NOTES:

1. INLET & OUTLET FLANGES ARE 8" 150# RF PER ANSI B16.5 REQUIRING 8X ϕ 3/4" BOLTS (BOLTS AND GASKETS NOT INCLUDED).
2. MAXIMUM PRESSURE: 100 psi (6.89 bar).
3. MAXIMUM TEMPERATURE: 400°F (204°C).
4. PRESSURE LOSS: 3-12 psi (.2-.8 bar) AT RATED FLOW.
5. RATED FLOW: 1450-2700 gpm (330-615 m³/hr).
6. APPROXIMATE DRY WEIGHT: 1373 lbs (623 kg).
7. FINISH: GLASS BLAST (EXTERIOR ONLY).
8. THREADED CONNECTIONS SEALED USING TEFLON PASTE SEALANT JOHN CRANE JC-30 OR EQUIVALENT.
9. GASKETS: SPIRAL WOUND, 304 SS W/PTFE FILLER.

THIS DRAWING HAS BEEN GENERATED AND IS MAINTAINED BY A CAD SYSTEM. CHANGES SHALL ONLY BE INCORPORATED AS DIRECTED BY AN APPROVED ENGINEERING CHANGE ORDER (ECO). PAPER COPIES ARE UNCONTROLLED.

REVISION HISTORY				
ZONE	REV	DESCRIPTION	DATE	APPROVED

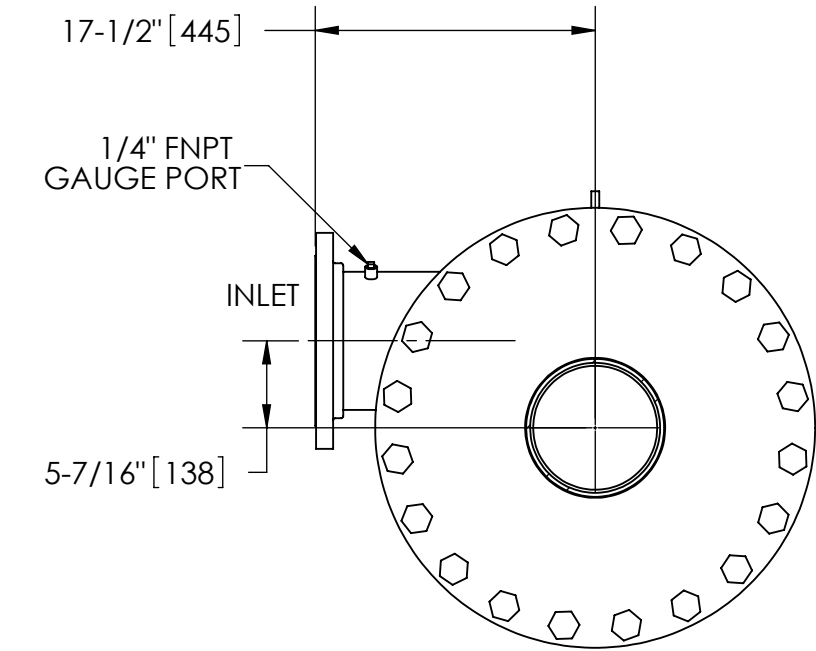
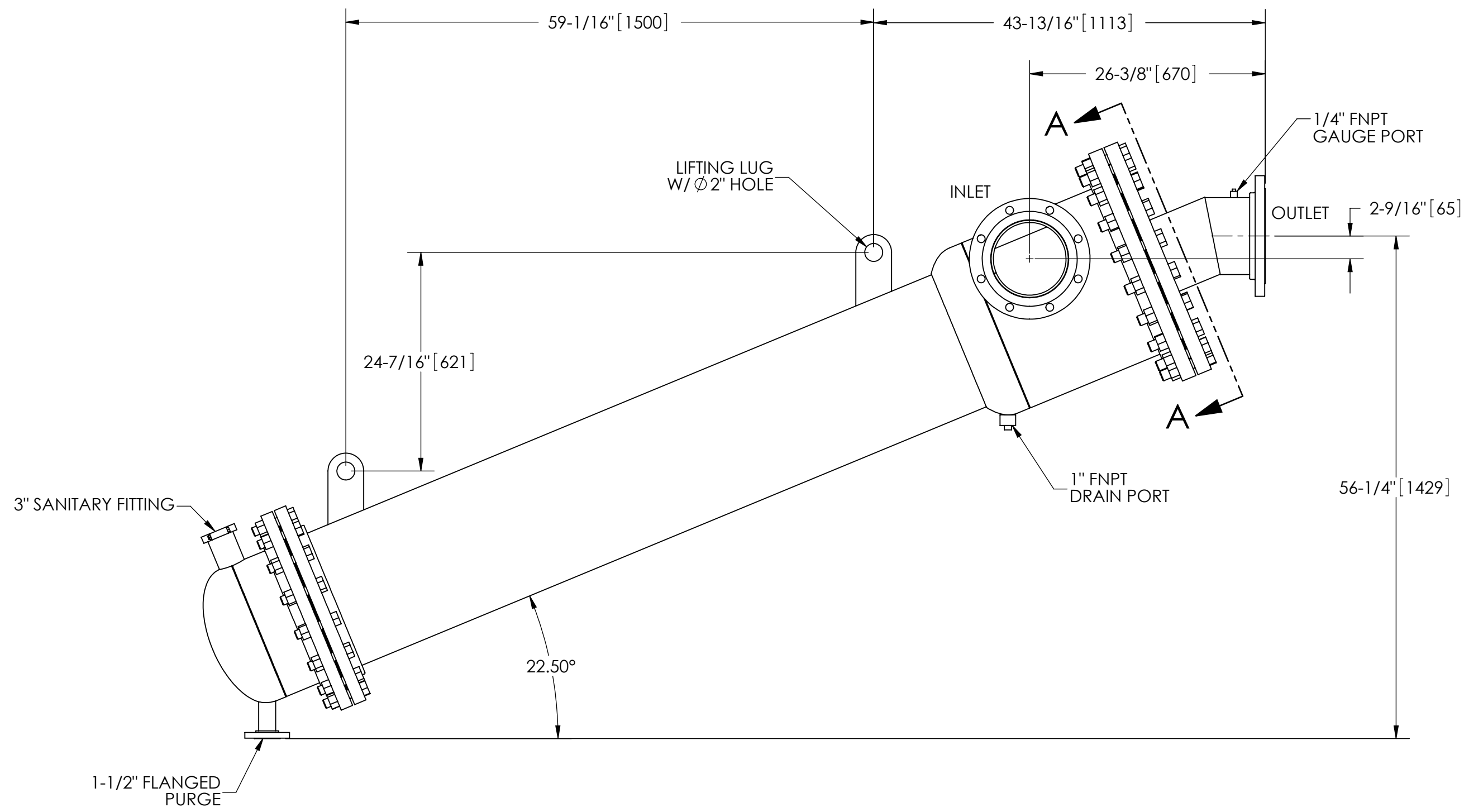

SECTION A-A

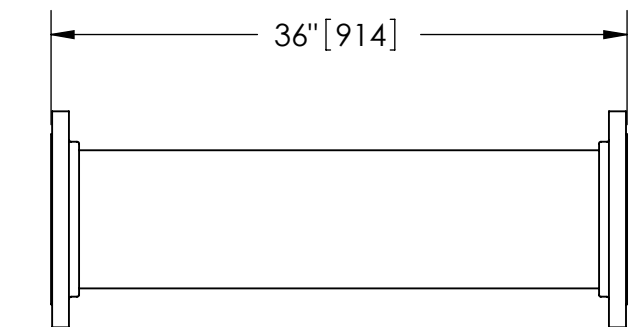

FLANGED SPOOL
 MODEL FS-08/S4 (AVAILABLE SEPARATELY)
 REQUIRED FOR REMOVAL OF TOP ASSEMBLY

SUBMITTAL DRAWING

This drawing is submitted for spatial consideration only. Do not pre-plumb to these dimensions.

UNLESS OTHERWISE SPECIFIED: DIMENSIONS ARE IN: INCHES [mm] TOLERANCES ARE:		ENGINEERED FOR: 304L SS		CLAUDE LAVAL CORP. FRESNO, CALIFORNIA 93727 WWW.LAKOS.COM		LAVAL UNDERGROUND SURVEYS		
FRACTIONS ± 1"	DECIMALS .XX ± .01 .XXX ± .005 .XXXX ± .0005	ANGLES ± 1/4°	APPROVALS	DATE	TITLE CSX-1450-HL/S4, SEPARATOR, 1450-2700 gpm, 304L SS			
DO NOT SCALE DRAWING			DRAWN AMF	11/4/11	SIZE C	MODEL NO.	DWG NO. 118198	REV. 01
MATERIAL TYPE 304L STAINLESS STEEL			ENGR -	-	SCALE 1:12	EST. WT. 1373 lb	SHEET 1 OF 1	
FINISH SEE NOTES			MFG -	-				
			WORK ORDER	QTY.				

DWG. NO. 118198
 SH 1
 REV. 01