

EXCEPT AS OTHERWISE PROVIDED BY CONTRACT, THIS DRAWING AND SPECIFICATIONS SHALL NOT BE REPRODUCED, COPIED OR USED AS THE BASIS FOR MANUFACTURE OR SALE OF MATTER DEPICTED HEREIN WITHOUT THE EXPRESSED WRITTEN PERMISSION OF THE CLAUDE LAVAL CORPORATION, OR ITS ASSIGNEES.

REVISIONS				
ZONE	REV	DESCRIPTION	DATE	APPROVED

THIS DRAWING HAS BEEN GENERATED AND IS MAINTAINED BY A CAD SYSTEM. CHANGES SHALL ONLY BE INCORPORATED AS DIRECTED BY AN APPROVED ENGINEERING CHANGE ORDER (ECO). PAPER COPIES ARE UNCONTROLLED.

SUBMITTAL DRAWING

This drawing is submitted for special consideration only. Do not pre-plumb to these dimensions. Certified drawings available upon request.

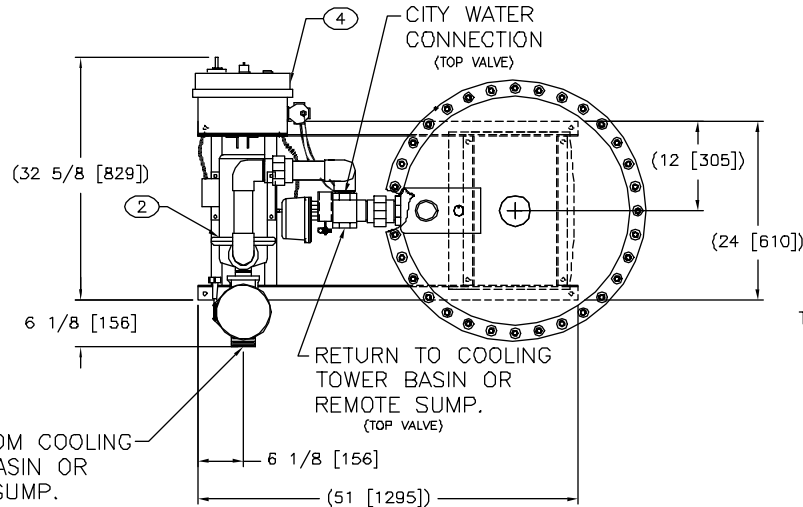

TOP VIEW

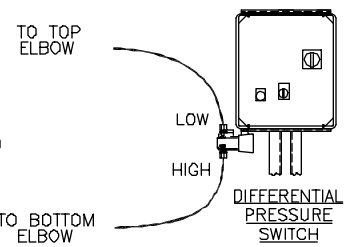

PRESSURE DIFFERENTIAL SETTINGS	
20" UNITS	= 13 PSI
24" UNITS	= 13 PSI
30" UNITS	= 16 PSI
TIMER SETTING	
ONE SHOT TIMER	- 180 SECS.

NOTES:

- INLET IS 2" PIPE SIZE (FNPT).
- OUTLET IS 2" PIPE SIZE (FNPT).
- BACKWASH IS 2" PIPE SIZE (FNPT).
- MAXIMUM PRESSURE: 50 psi. (345 kPa).
- MAXIMUM TEMPERATURE: 125°F (51.7°C).
- SPECIFIED MAXIMUM FLOWRATE OF 100 GPM (23 m³/hr).
- SPECIFIED MINIMUM BACKWASH FLOW RATE OF 74 GPM (17 m³/hr).
- POWER REQUIREMENT: 480V, 3PH, 60HZ.
- NEMA 4X MOTOR STARTER ENCLOSURE WITH SAFETY DISCONNECT, H.O.A. SWITCH, BACKWASH TIMER AND BACKWASH CYCLE TIMER.
- APPROXIMATE DRY WEIGHT: 725lbs (329 kg).
- MINIMUM PIPE SIZE AT FTS SYSTEM INLET IS 3" PIPE.
- FLOODED SUCTION REQUIRED.
- FINISH: AS ASSEMBLED.

COMPONENT LIST:

- MEDIA TANK: 30" DIAMETER FIBERGLASS REINFORCED POLYESTER FILTER.
- PUMP: 2 HP CENTRIFUGAL, STAINLESS STEEL, 3500 rpm.
- PLASTIC BASKET STRAINER.
- ELECTRICAL CONTROL BOX: 480V 60HZ W/115V TRANSFORMER.
- MEDIA: 10 MICRON AT 95% EFFICIENCY - STANDARD.
5 MICRON AT 90% EFFICIENCY - OPTIONAL.
- UNDERDRAIN: PVC CENTER MANIFOLD, ABS COLLECTOR HUB FOR 16 ABS COLLECTOR LATERALS.
- ELECTRIC ACTUATOR: 120 V ELECTRICALLY ACTUATED 3-WAY BALL VALVES
- OPEN RAIL, STAINLESS STEEL SKID.

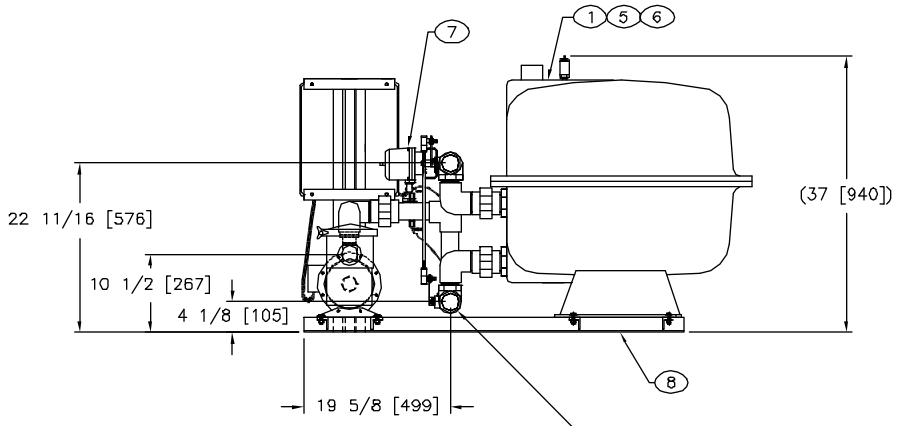

FRONT VIEW

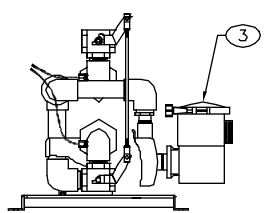

LEFT SIDE VIEW
TANK, ACTUATOR & ELECTRICAL GROUP NOT SHOWN FOR CLARITY

UNLESS OTHERWISE SPECIFIED: DIMENSIONS ARE IN INCHES (mm) TOLERANCES ARE: FRACTIONS DECIMALS ANGLES ± 1/2" ± .005 ± 1/4" DO NOT SCALE DRAWING	DESIGNED FOR: STANDARD	LAKOS CLAUDE LAVAL CORP. 1385 N. CLOVIS AVE. FRESNO, CALIFORNIA 93727	LAKOS UNIVERSITY SURETY
APPROVALS	DATE	TITLE	
DRAWN NAC	4/17/02	FTS-30-100-A-C, HT MEDIA SYSTEM	
REVIEWED		CITY BW, AUTO, FIBERGLASS 2 HP	
SEE PARTS LIST			
FINISH: AS ASSEMBLED	ENGR 4/26/02	SIZE C	MODEL NO. 119193
WORK ORDER	QTY.	SCALE 1" = 1'	EST. WGT. SHEET 1 OF 1

DWG. NO. 119193