

EXCEPT AS OTHERWISE PROVIDED BY CONTRACT, THIS DRAWING AND SPECIFICATIONS SHALL NOT BE REPRODUCED, COPIED OR USED AS THE BASIS FOR MANUFACTURE OR SALE OF WATER EQUIPMENT HEREIN WITHOUT THE EXPRESSED WRITTEN PERMISSION OF THE CLAUDE LAVAL CORPORATION, OR ITS ASSIGNEES.

NOTES:

1. INLET & OUTLET IS 2-1/2" MPT.
2. MAXIMUM PRESSURE: 150 psi. (1034 kPa).
3. MAXIMUM TEMPERATURE: 180°F (82.2°C).
4. PRESSURE LOSS: 5.0-12.0 psid AT RATED FLOW.
5. RATED FLOW: 95-155 gpm (21.5-35.0 m³/hr).
6. APPROXIMATE DRY WEIGHT: 55 lbs. (24.9 kg.).

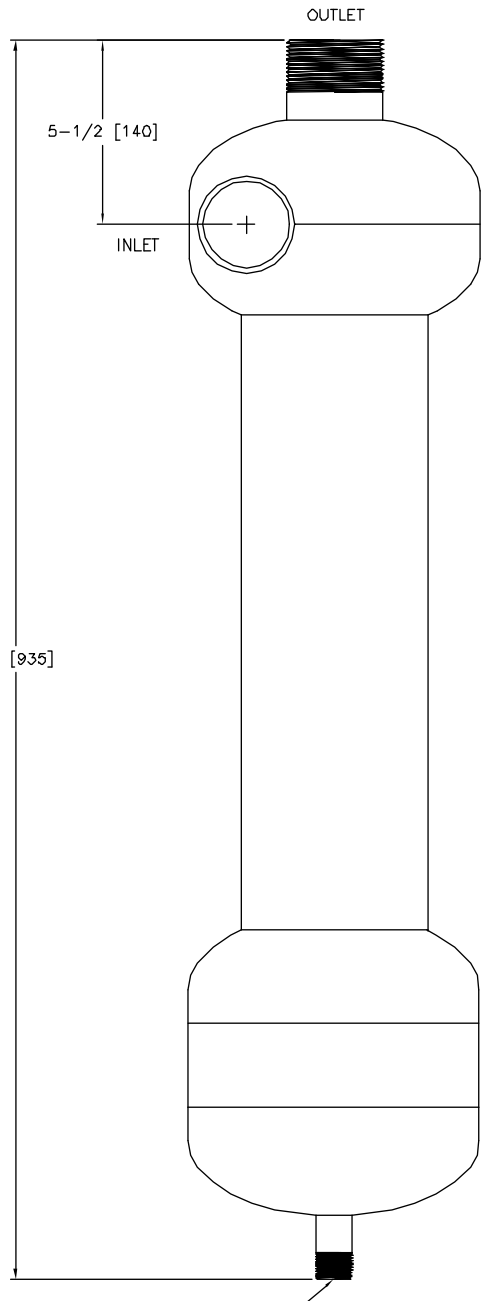

REVISIONS				
ZONE	REV	DESCRIPTION	DATE	APPROVED

THIS DRAWING HAS BEEN GENERATED AND IS MAINTAINED BY A CAD SYSTEM. CHANGES SHALL ONLY BE INCORPORATED AS DIRECTED BY AN APPROVED ENGINEERING CHANGE ORDER (ECO). PAPER COPIES ARE UNCONTROLLED.

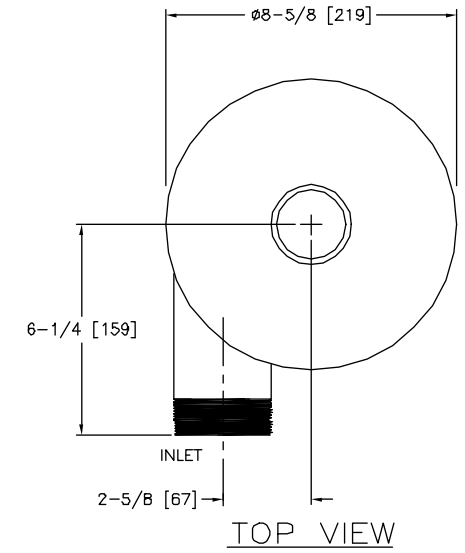

SUBMITTAL DRAWING

This drawing is submitted for special consideration only. Do not pre-plumb to these dimensions. Certified drawings available upon request.

<small>UNLESS OTHERWISE SPECIFIED: DIMENSIONS ARE IN INCHES (mm) TOLERANCES ARE: FRACTIONS DECIMALS ANGLES ±1/4 ±.01 ±1/4° ±1/8 ±.005 ±1/8° ±1/16 ±.0005 ±1/16° DO NOT SCALE DRAWING</small>	<small>ENGINEERED FOR:</small> STANDARD	<small>LAVAL</small> CLAUDE LAVAL CORP. 1365 N. CLOVIS AVE. FRESNO, CALIFORNIA 93727	
	<small>APPROVALS</small> DATE DRAWN R. JONES 8/16/96 REVIEWED <i>[Signature]</i> 8/5/00		