

EXCEPT AS OTHERWISE PROVIDED BY CONTRACT, THIS DRAWING AND SPECIFICATIONS SHALL NOT BE REPRODUCED, COPIED OR USED AS THE BASIS FOR MANUFACTURE OR SALE OF MATTER DEPICTED HEREIN WITHOUT THE EXPRESSED WRITTEN PERMISSION OF THE CLAUDE LAVAL CORPORATION, OR ITS ASSIGNEES.

REVISIONS				
ZONE	REV	DESCRIPTION	DATE	APPROVED
-	A	UPDATED FLOW RATES	7/2/03	NAC
-	B	NEW VALVES AN LAYOUT	11/7/03	NAC

THIS DRAWING HAS BEEN GENERATED AND IS MAINTAINED BY A CAD SYSTEM. CHANGES SHALL ONLY BE INCORPORATED AS DIRECTED BY AN APPROVED ENGINEERING CHANGE ORDER (ECO). PAPER COPIES ARE UNCONTROLLED.

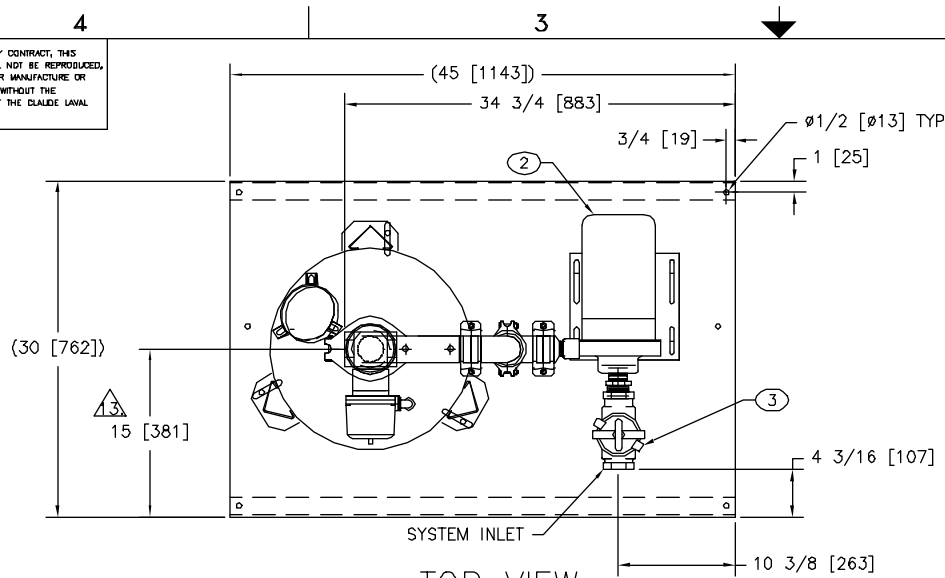

TOP VIEW

ELECTRICAL GROUP NOT SHOWN FOR CLARITY

NOTES:

1. INLET IS 1-1/2" (FNPT).
2. OUTLET IS 2" (GROOVED).
3. BACKWASH IS 2" (FNPT).
4. MAXIMUM PRESSURE: 100 psi (6.9 bar).
5. MAXIMUM TEMPERATURE: 100°F (37.8°C).
6. SPECIFIED MAXIMUM FLOWRATE OF 45 gpm (10 m³/hr).
7. SPECIFIED MINIMUM BACKWASH FLOW RATE OF 27 gpm (6 m³/hr).
8. POWER REQUIREMENT: 460V, 3PH, 60HZ
9. NEMA 4X MOTOR STARTER ENCLOSURE WITH SAFETY DISCONNECT, H.O.A. SWITCH, 24 HR BACKWASH TIMER AND BACKWASH CYCLE TIMER.
10. APPROXIMATE DRY WEIGHT: 517 lbs (235 kg).
11. MINIMUM PIPE SIZE TO STS SYSTEM INLET IS 2".
12. FLOODED SUCTION REQUIRED.
13. DIM APPLICABLE TO BOTH OUTLET & BACKWASH DRAIN.
14. FINISHED: AS ASSEMBLED

- ① MEDIA TANK: 18" DIAMETER STAINLESS STEEL FILTER.
- ② PUMP: 1 HP CENTRIFUGAL, CAST IRON, TEFC, 3500 rpm.
- ③ STRAINER: CAST IRON BASKET STRAINER.
- ④ ELECTRICAL CONTROL BDY: 460V 60HZ W/115V TRANSFORMER.
- ⑤ MEDIA: 10 MICRON AT 95% EFFICIENCY - STANDARD.
5 MICRON AT 90% EFFICIENCY - OPTIONAL.
- ⑥ UNDERDRAIN: 5/40 PVC HEADER, PVC INTERNALLY SLOTTED WELL SCREEN.
- ⑦ INLET/OUTLET PRESSURE GAUGES: 0-100 PSI, GLYCERIN-FILLED.

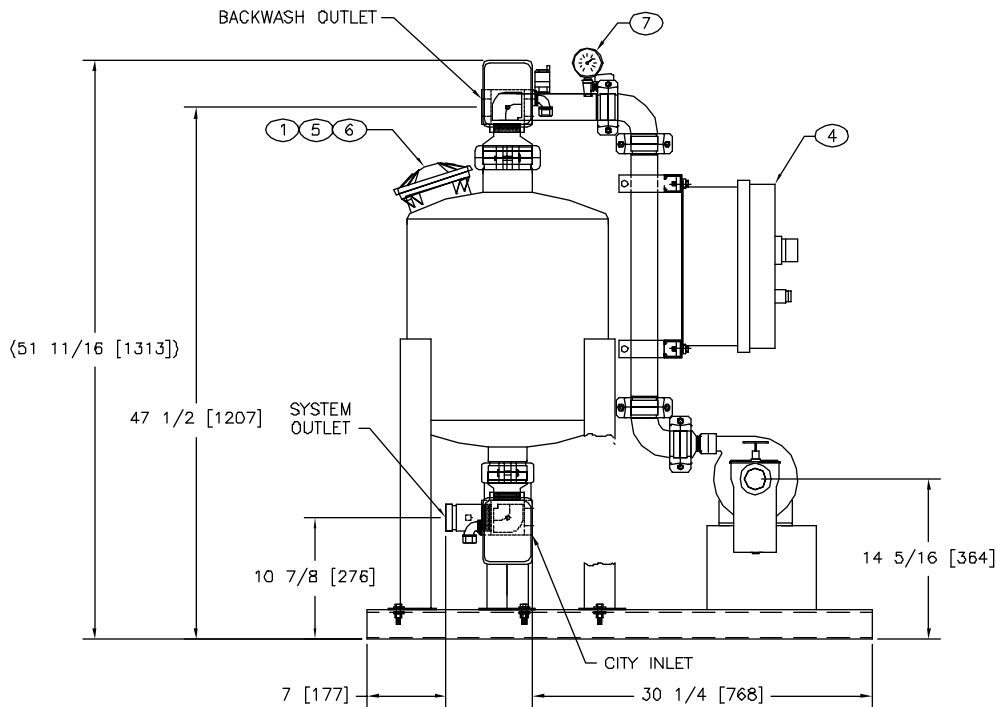

FRONT VIEW

SUBMITTAL DRAWING

This drawing is submitted for spatial consideration only. Do not pre-plumb to these dimensions.

UNLESS OTHERWISE SPECIFIED: DIMENSIONS ARE IN INCHES (mm) TOLERANCES ARE: FRACTIONS DECIMALS ANGLES ± 1/2" ± .005 ± 1/4" DO NOT SCALE DRAWING	DESIGNED FOR: STANDARD	LAKOS	CLAUDE LAVAL CORP. 1385 N. CLOVIS AVE. FRESNO, CALIFORNIA 93727	LAKOS UNDRERDRAIN SURETY
	APPROVALS	DATE	TITLE	
MATERIAL SEE LAKOS SPEC	DRAWN NAC	4/8/02	STS-18-045-A-C, SS MEDIA SYSTEM CITY BW, AUTO, 460V 60HZ	
FINISH AS ASSEMBLED	REVIEWED ENR	12/8/03	SIZE C	MODEL NO. 117975
	WORK ORDER	QTY.	SCALE 1/8"	DWG. NO. 117975
				SHEET 1 OF 1

DWG. NO. 117975

A