

EXCEPT AS OTHERWISE PROVIDED BY CONTRACT, THIS DRAWING AND SPECIFICATIONS SHALL NOT BE REPRODUCED, COPIED OR USED AS THE BASIS FOR MANUFACTURE OR SALE OF MATTER DEPICTED HEREIN WITHOUT THE EXPRESSED WRITTEN PERMISSION OF THE CLAUDE LAVAL CORPORATION, OR ITS ASSIGNEES.

REVISION HISTORY				
ZONE	REV	DESCRIPTION	DATE	APPROVED

THIS DRAWING HAS BEEN GENERATED AND IS MAINTAINED BY A CAD SYSTEM. CHANGES SHALL ONLY BE INCORPORATED AS DIRECTED BY AN APPROVED ENGINEERING CHANGE ORDER (ECO). PAPER COPIES ARE UNCONTROLLED.

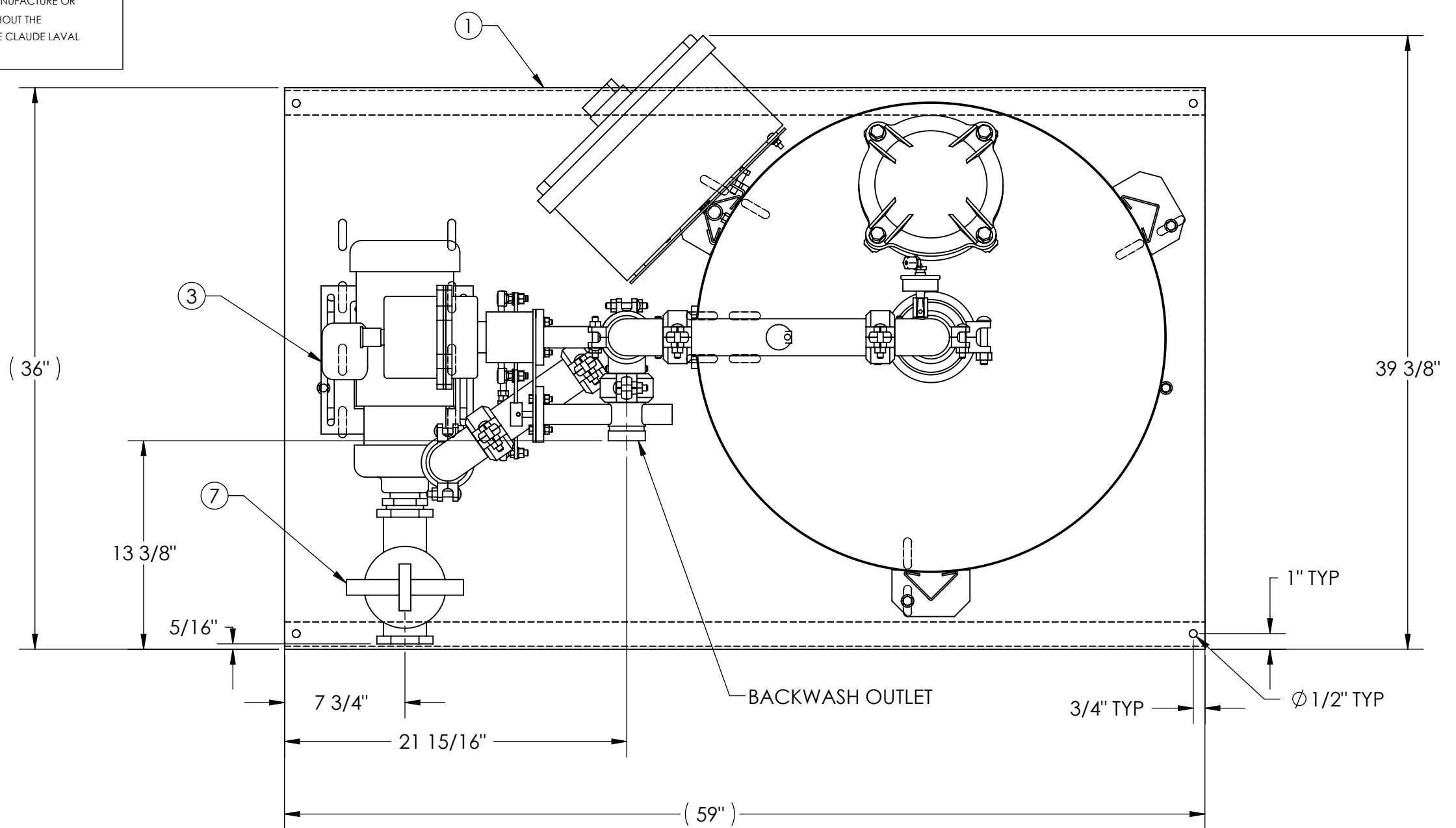

NOTES:

- INLET IS 2" PIPE (NPT).
- OUTLET IS 2" PIPE (GROOVED).
- BACKWASH IS 2" PIPE (GROOVED).
- MAXIMUM PRESSURE: 100 psi (6.9 bar).
- MAXIMUM TEMPERATURE: 100°F (37.8°C).
- SPECIFIED MAXIMUM FLOWRATE OF 110 gpm (25 m³/hr).
- SPECIFIED MINIMUM BACKWASH FLOWRATE OF 73 gpm (17 m³/hr).
- FINISH: AS ASSEMBLED.
- POWER REQUIREMENT: 460V, 3PH, 60Hz.
- NEMA 4X MOTOR STARTER ENCLOSURE WITH SAFETY DISCONNECT, H.O.A. SWITCH, 24 HR BACKWASH TIMER, AND BACKWASH CYCLE TIMER.
- APPROXIMATE DRY WEIGHT (INCLUDING 500 lbs SAND): 1088 lbs (494 kg).
- MINIMUM PIPE SIZE TO STS SYSTEM IS 2-1/2" PIPE.
- FLOODED SUCTION REQUIRED.

COMPONENT LIST:

- ELECTRICAL CONTROL BOX 460V 60Hz W/120V TRANSFORMER.
- MEDIA TANK: 30" DIAMETER STAINLESS STEEL FILTER.
- PUMP: 2 HP CENTRIFUGAL, 3500 rpm, TEFC, 460V, 60Hz, CAST IRON.
- INLET/OUTLET PRESSURE GAUGES: 0-100 psi, GLYCERIN-FILLED.
- MEDIA: 10 MICRON AT 95% EFFICIENCY - STANDARD
5 MICRON AT 90% EFFICIENCY - OPTIONAL
- UNDERDRAIN: S/40 PVC HEADER, PVC INTERNALLY SLOTTED WELL SCREEN.
- BASKET STRAINER, CAST IRON.

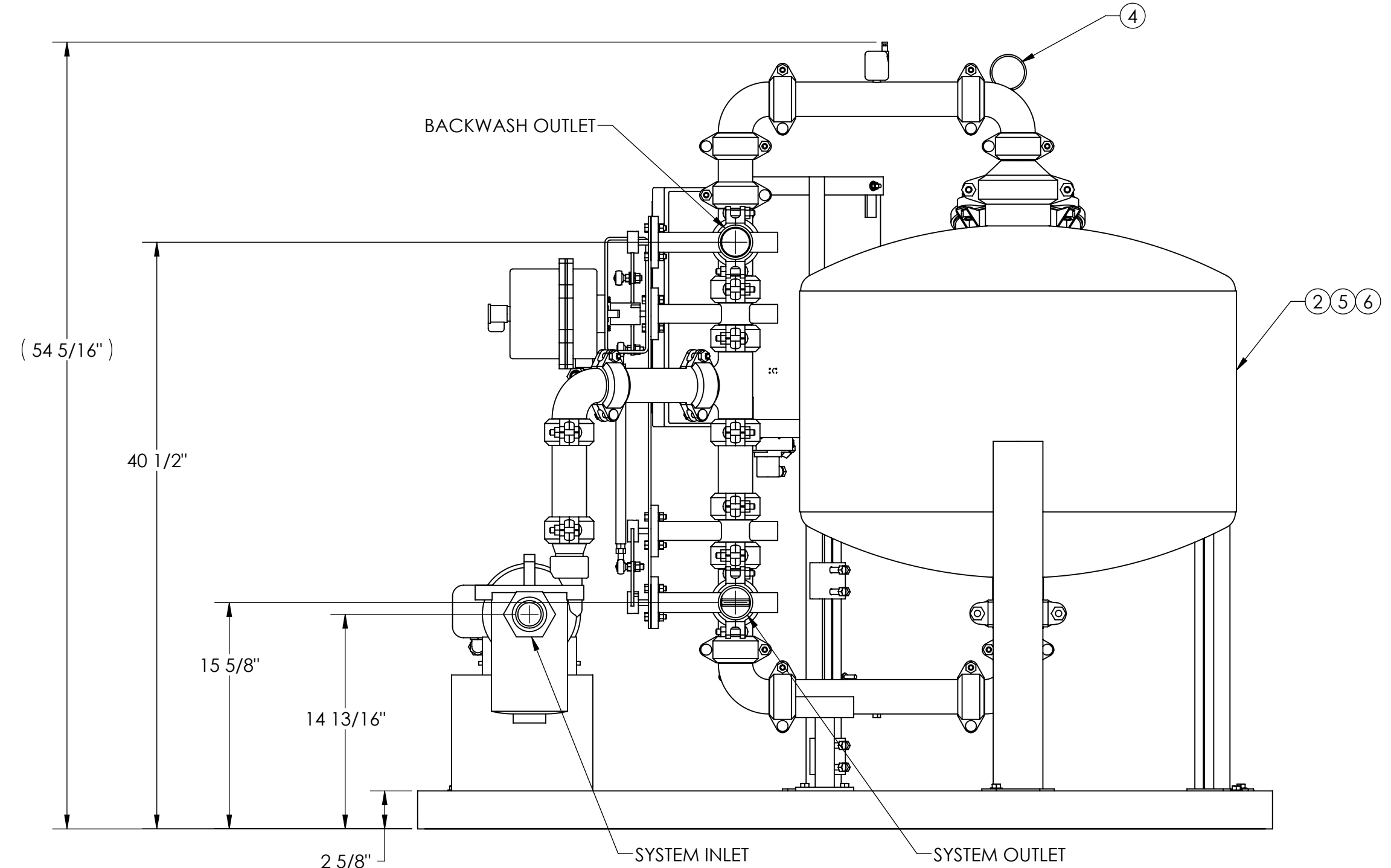

SUBMITTAL DRAWING

This drawing is submitted for spatial consideration only. Do not pre-plumb to these dimensions.

UNLESS OTHERWISE SPECIFIED: DIMENSIONS ARE IN: INCHES (mm) TOLERANCES ARE: FRACTIONS DECIMALS ANGLES ± 1/2" .XX ± .01 ± 1/4" .XXX ± .005 .XXXX ± .0005		ENGINEERED FOR: STANDARD		CLAUDE LAVAL CORP. FRESNO, CALIFORNIA 93727 WWW.LAKOS.COM		LAVAL UNDERGROUND SURVEYS		
DO NOT SCALE DRAWING		APPROVALS	DATE	TITLE				
MATERIAL		DRAWN	2/3/06	STS-30-110-A-S, SS MEDIA SYSTEM, SYSTEM BW, AUTO, 460V 60HZ				
FINISH		ENGR	-	SIZE		MODEL NO.	DWG NO.	REV.
AS ASSEMBLED		MFG	-	C			117978	E
		WORK ORDER	-	SCALE		EST. WT.	SHEET	
				1:8		588 lb	1 OF 1	

DWG. NO. 117978 SHEET 1 REV. E