

EXCEPT AS OTHERWISE PROVIDED BY CONTRACT, THIS DRAWING AND SPECIFICATIONS SHALL NOT BE REPRODUCED, COPIED OR USED AS THE BASIS FOR MANUFACTURE OR SALE OF MATTER DEPICTED HEREIN WITHOUT THE EXPRESSED WRITTEN PERMISSION OF THE CLAUDE LAVAL CORPORATION, OR ITS ASSIGNEES.

REVISION HISTORY				
ZONE	REV	DESCRIPTION	DATE	APPROVED

THIS DRAWING HAS BEEN GENERATED AND IS MAINTAINED BY A CAD SYSTEM. CHANGES SHALL ONLY BE INCORPORATED AS DIRECTED BY AN APPROVED ENGINEERING CHANGE ORDER (ECO). PAPER COPIES ARE UNCONTROLLED.

**NOTES:**

1. INLET IS 3" PIPE (GROOVED).
2. OUTLET IS 2-1/2" PIPE (GROOVED).
3. PURGE OUTLET IS 3/4" PIPE.
4. MAXIMUM PRESSURE: 150 psi (10.3 bar).
5. MAXIMUM TEMPERATURE: 100°F (37.8°C).
6. SPECIFIED FLOWRATE OF 0145 gpm (33 m<sup>3</sup>/hr).
7. FINISH: AS ASSEMBLED.
8. POWER REQUIREMENT: 460V, 3PH, 60Hz.
9. NEMA 4X MOTOR STARTER ENCLOSURE WITH SAFETY DISCONNECT AND H.O.A. SWITCH.
10. APPROXIMATE DRY WEIGHT: 610 lbs (277 kg).
11. INLET/OUTLET VALVE KIT, MODEL TCV-0145 RECOMMENDED.
12. MINIMUM PIPE TO TB SYSTEM IS 4" PIPE.
13. FLOODED SUCTION REQUIRED.

**COMPONENT LIST:**

- ① ELECTRICAL CONTROL BOX 460V 60Hz W/120V TRANSFORMER.
- ② SEPARATOR: HTX-0085-TC.
- ③ PUMP: 3 HP CENTRIFUGAL, 1750 rpm, 460V, 60Hz.
- ④ INLET/OUTLET PRESSURE GAUGES: 0-100 psi, GLYCERIN-FILLED.
- ⑤ PURGE EQUIPMENT: SRV-816.
- ⑥ DIFFERENTIAL PRESSURE INDICATOR: (AVAILABLE WITH DRY DRY CONTACT-MODEL DHE-15-S. ORDER SEPARATELY).

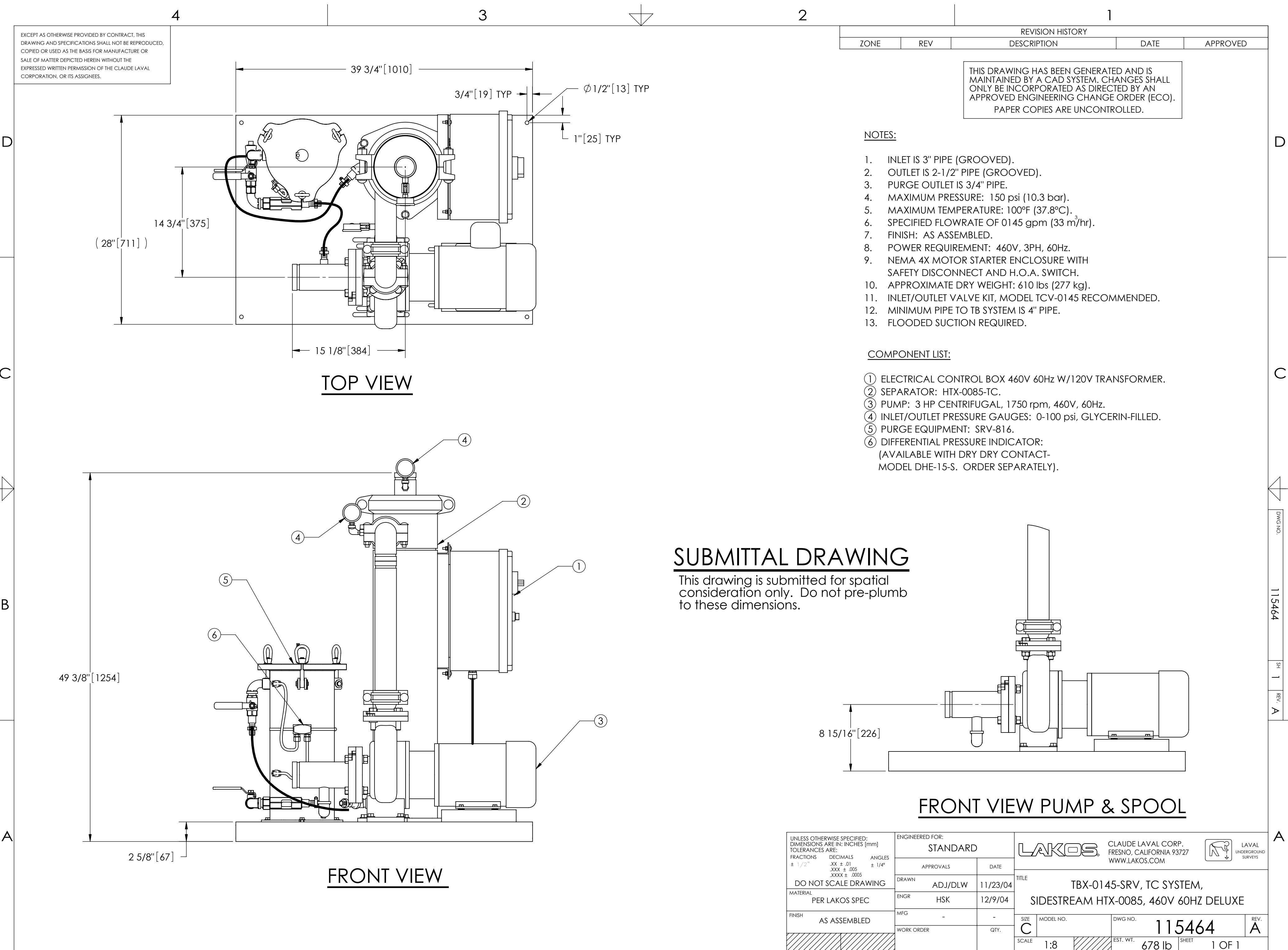

**SUBMITTAL DRAWING**  
 This drawing is submitted for spatial consideration only. Do not pre-plumb to these dimensions.

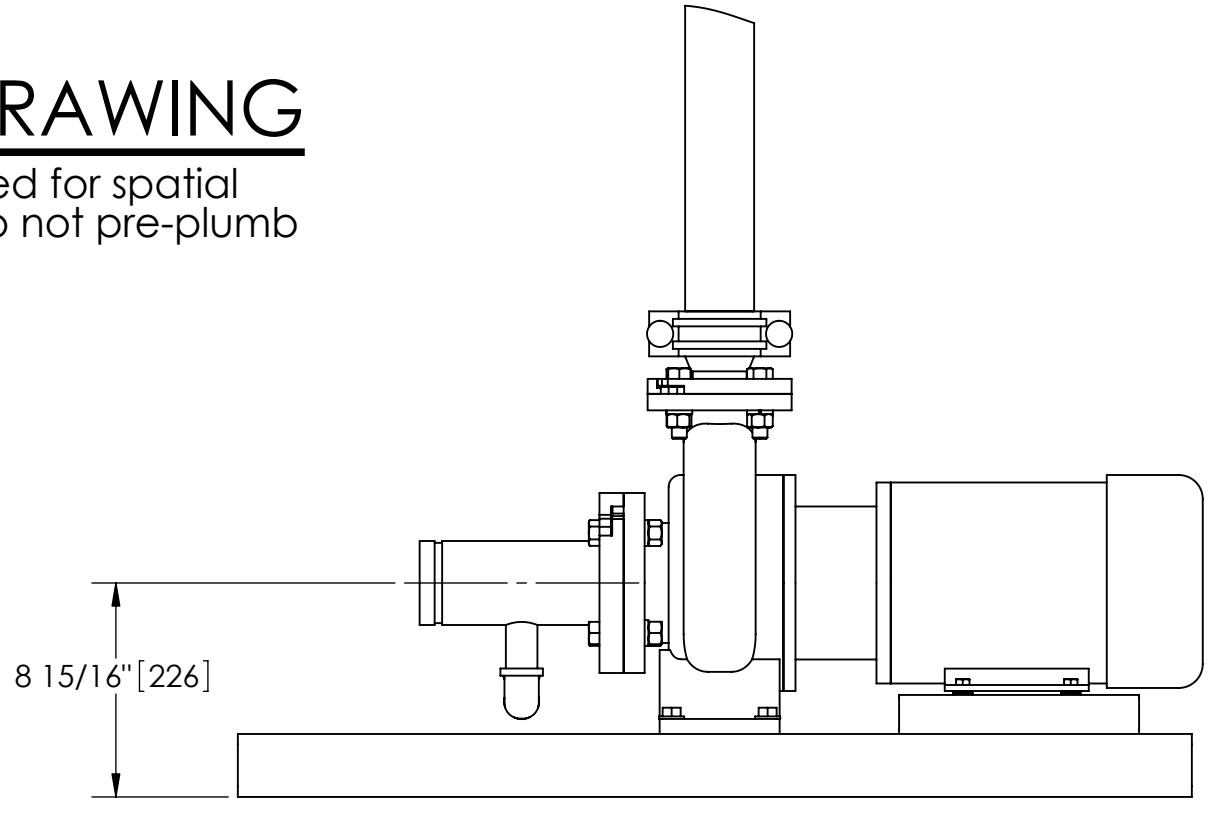

**FRONT VIEW PUMP & SPOOL**

<small>UNLESS OTHERWISE SPECIFIED:          DIMENSIONS ARE IN: INCHES (mm)          TOLERANCES ARE:          FRACTIONS DECIMALS ANGLES  <math>\pm 1/2"</math> .XX <math>\pm .01</math> <math>\pm 1/4^\circ</math>          .XXX <math>\pm .005</math>          .XXXX <math>\pm .0005</math></small>	ENGINEERED FOR: <b>STANDARD</b>		<b>LAKOS</b> CLAUDE LAVAL CORP. FRESNO, CALIFORNIA 93727 WWW.LAKOS.COM			
	APPROVALS	DATE	TITLE			
	DO NOT SCALE DRAWING	DRAWN ADJ/DLW	11/23/04	TBX-0145-SRV, TC SYSTEM, SIDESTREAM HTX-0085, 460V 60HZ DELUXE		
	MATERIAL PER LAKOS SPEC	ENGR HSK	12/9/04	SIZE C	MODEL NO.	DWG NO. 115464
FINISH AS ASSEMBLED	MFG -	-	SCALE 1:8	EST. WT. 678 lb	SHEET 1 OF 1	