

EXCEPT AS OTHERWISE PROVIDED BY CONTRACT, THIS DRAWING AND SPECIFICATIONS SHALL NOT BE REPRODUCED, COPIED OR USED AS THE BASIS FOR MANUFACTURE OR SALE OF MATTER DEPICTED HEREIN WITHOUT THE EXPRESSED WRITTEN PERMISSION OF THE CLAUDE LAVAL CORPORATION, OR ITS ASSIGNEES.

REVISION HISTORY				
ZONE	REV	DESCRIPTION	DATE	APPROVED
	A	REMOVED SMITH-BLAIR CPLG	2/11/00	SGF
	B	CONVERTED TO GROUPS	5/17/00	SDF

THIS DRAWING HAS BEEN GENERATED AND IS MAINTAINED BY A CAD SYSTEM. CHANGES SHALL ONLY BE INCORPORATED AS DIRECTED BY AN APPROVED ENGINEERING CHANGE ORDER (ECO). PAPER COPIES ARE UNCONTROLLED.

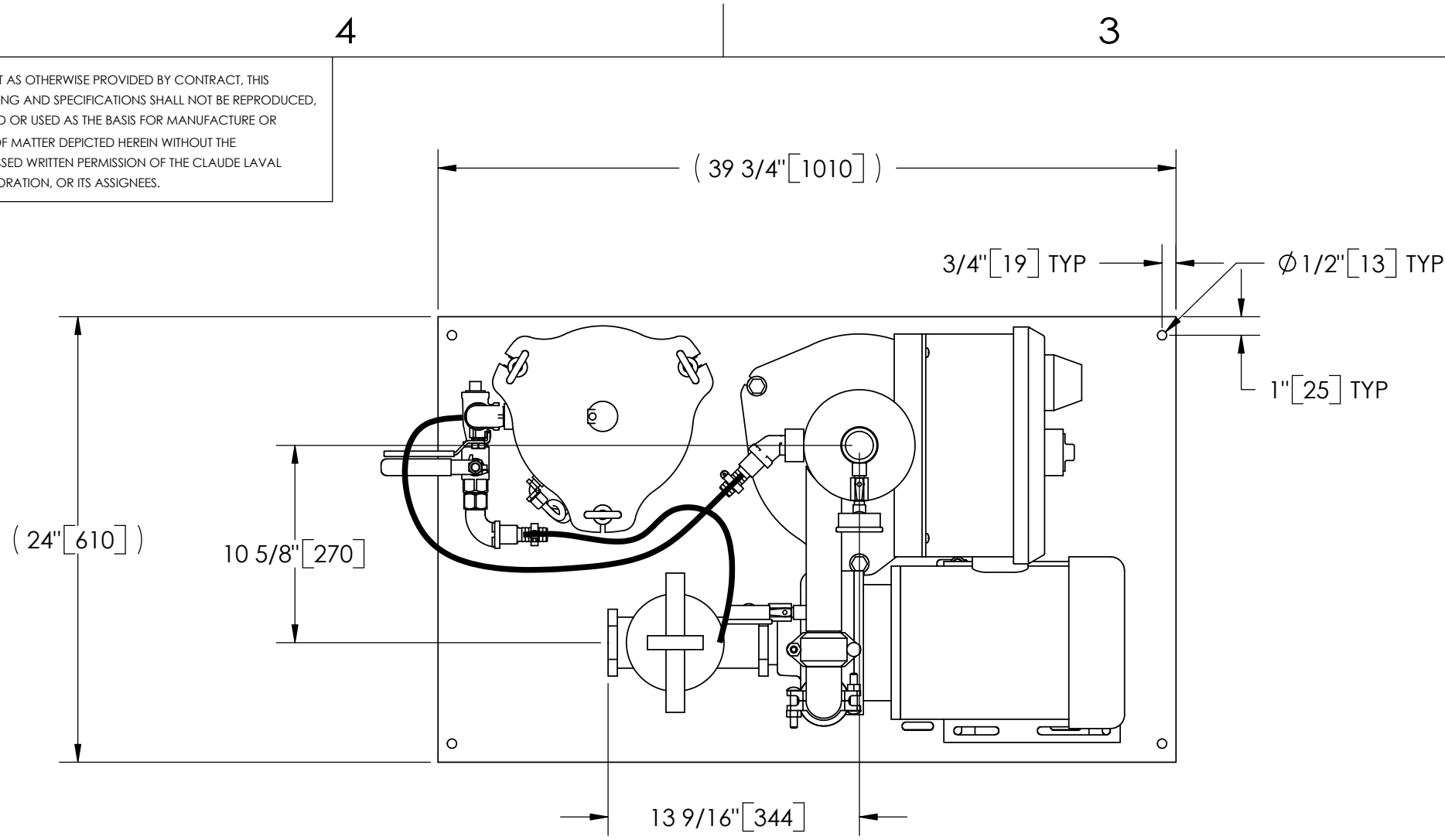

**TOP VIEW**

**NOTES:**

1. INLET IS 2" PIPE ( NPT).
2. OUTLET IS 1-1/2" PIPE (GROOVED).
3. PURGE OUTLET IS 3/4" PIPE.
4. MAXIMUM PRESSURE: 150 psi (10.3 bar).
5. MAXIMUM TEMPERATURE: 100°F (37.8°C).
6. SPECIFIED FLOWRATE OF 65 gpm (15 m<sup>3</sup>/hr).
7. FINISH: AS ASSEMBLED.
8. POWER REQUIREMENT: 460V, 3PH, 60Hz.
9. NEMA 4X MOTOR STARTER ENCLOSURE WITH SAFETY DISCONNECT AND H.O.A. SWITCH.
10. APPROXIMATE DRY WEIGHT: 337 lbs (153 kg).
11. INLET/OUTLET VALVE KIT, MODEL TCV-0065 RECOMMENDED.
12. MINIMUM PIPE FROM TOWER BASIN TO TC SYSTEM IS 2-1/2" PIPE.
13. FLOODED SUCTION REQUIRED.

**COMPONENT LIST:**

- ① ELECTRICAL CONTROL BOX 460V 60Hz W/120V TRANSFORMER.
- ② SEPARATOR: ILB-0150-TC.
- ③ PUMP: 3 HP CENTRIFUGAL, 3500 rpm, 460V, 60Hz.
- ④ INLET/OUTLET PRESSURE GAUGES: 0-100 psi, GLYCERIN-FILLED.
- ⑤ PURGE EQUIPMENT: SRV-816.
- ⑥ DIFFERENTIAL PRESSURE INDICATOR: (AVAILABLE WITH DRY DRY CONTACT-MODEL DHE-15-S. ORDER SEPARATELY).
- ⑦ BASKET STRAINER

**SUBMITTAL DRAWING**

This drawing is submitted for spatial consideration only. Do not pre-plumb to these dimensions.

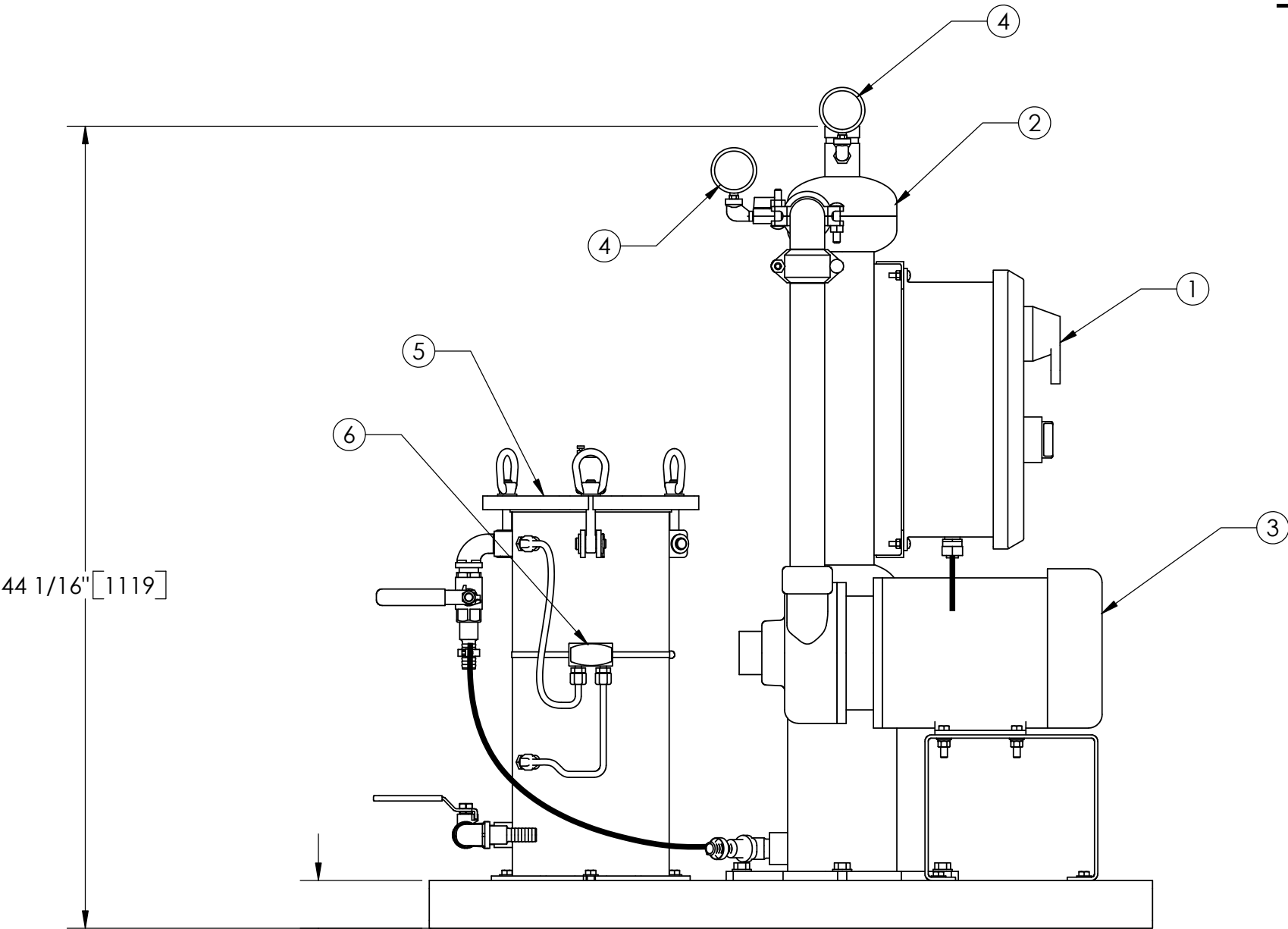

**FRONT VIEW W/O STRAINER**

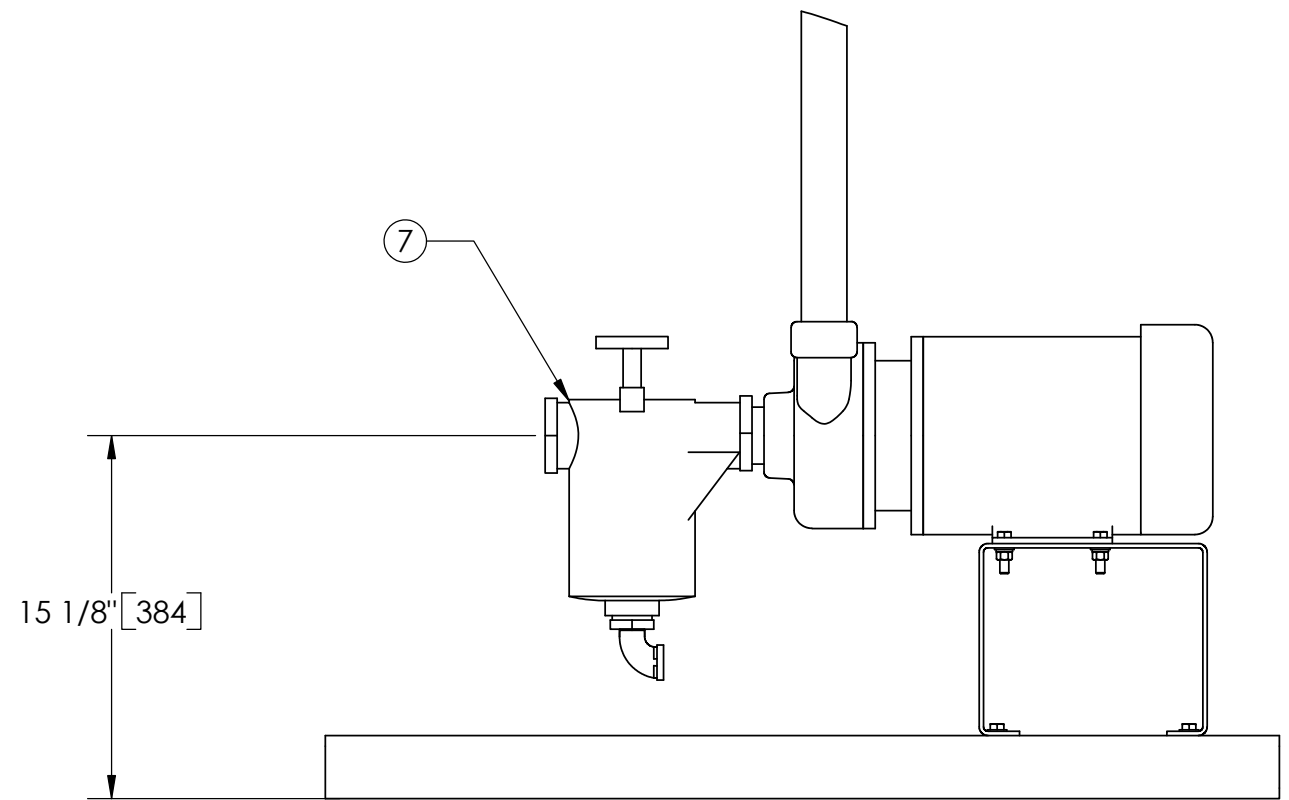

**FRONT VIEW PUMP & STRAINER**

<small>UNLESS OTHERWISE SPECIFIED: DIMENSIONS ARE IN: INCHES (mm) TOLERANCES ARE:</small> <small>FRACTIONS    DECIMALS    ANGLES</small> <small>± 1/2"        .XX ± .01        ± 1/4°</small> <small>                 .XXX ± .005        ± 1/8"</small> <small>                 .XXXX ± .0005</small>	ENGINEERED FOR:		<b>LAKOS</b> CLAUDE LAVAL CORP. FRESNO, CALIFORNIA 93727 WWW.LAKOS.COM			<small>LAVAL UNDERGROUND SURVEYS</small>	
	STANDARD						
	DO NOT SCALE DRAWING	APPROVALS	DATE	TITLE			
	MATERIAL	ENGR	DATE	TCI-0065-SRV, TC SYSTEM, SWEEPER ILB-0150, 460V 60HZ STD			
FINISH	MFG	-	SCALE	MODEL NO.	DWG NO.	REV.	
AS ASSEMBLED	WORK ORDER	QTY.	1:8		115416	B	
			EST. WT.	SHEET	1 OF 1		
			337 lb	1			

DWG NO. 115416 SH 1 REV. B