

EXCEPT AS OTHERWISE PROVIDED BY CONTRACT, THIS DRAWING AND SPECIFICATIONS SHALL NOT BE REPRODUCED, COPIED OR USED AS THE BASIS FOR MANUFACTURE OR SALE OF MATTER DEPICTED HEREIN WITHOUT THE EXPRESSED WRITTEN PERMISSION OF THE CLAUDE LAVAL CORPORATION, OR ITS ASSIGNEES.

THIS DRAWING HAS BEEN GENERATED AND IS MAINTAINED BY A CAD SYSTEM. CHANGES SHALL ONLY BE INCORPORATED AS DIRECTED BY AN APPROVED ENGINEERING CHANGE ORDER (ECO). PAPER COPIES ARE UNCONTROLLED.

REVISION HISTORY				
ZONE	REV	DESCRIPTION	DATE	APPROVED
-	A	REMOVED SMITH-BLAIR CPLG	2/22/00	SGF
-	B	CHANGED TO GROUPS	6/20/00	GMB

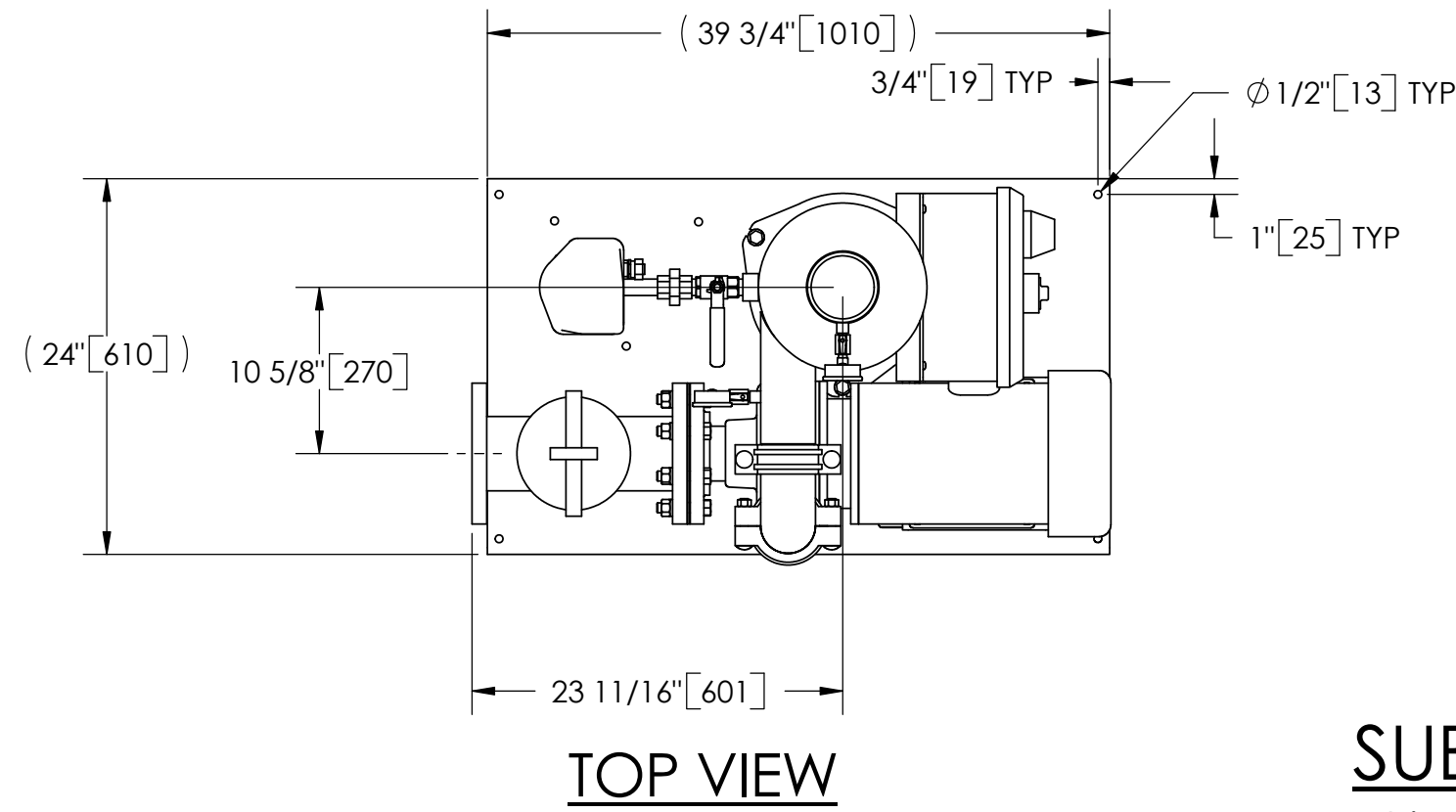

TOP VIEW

SUBMITTAL DRAWING

This drawing is submitted for spatial consideration only. Do not pre-plumb to these dimensions.

NOTES:

1. INLET IS 4" PIPE (125# ANSI FLANGED).
2. OUTLET IS 4" PIPE (GROOVED).
3. PURGE OUTLET IS 3/4" PIPE.
4. MAXIMUM PRESSURE: 150 psi (10.3 bar).
5. MAXIMUM TEMPERATURE: 100°F (37.8°C).
6. SPECIFIED FLOWRATE OF 280 gpm (64 m³/hr).
7. FINISH: AS ASSEMBLED.
8. POWER REQUIREMENT: 460V, 3PH, 60Hz.
9. NEMA 4X MOTOR STARTER ENCLOSURE WITH SAFETY DISCONNECT AND H.O.A. SWITCH.
10. APPROXIMATE DRY WEIGHT: 554 lbs (251 kg).
11. INLET/OUTLET VALVE KIT, MODEL TCV-0280 RECOMMENDED.
12. MINIMUM PIPE FROM TOWER BASIN TO TC SYSTEM IS 6" PIPE.
13. FLOODED SUCTION REQUIRED.

COMPONENT LIST:

- ① ELECTRICAL CONTROL BOX 460V 60Hz W/120V TRANSFORMER.
- ② SEPARATOR: ILB-0350-TC.
- ③ PUMP: 10 HP CENTRIFUGAL, 3500 rpm, 460V, 60Hz.
- ④ INLET/OUTLET PRESSURE GAUGES: 0-100 psi, GLYCERIN-FILLED.
- ⑤ PURGE EQUIPMENT: CMBV-07-120V.
- ⑥ BASKET STRAINER.

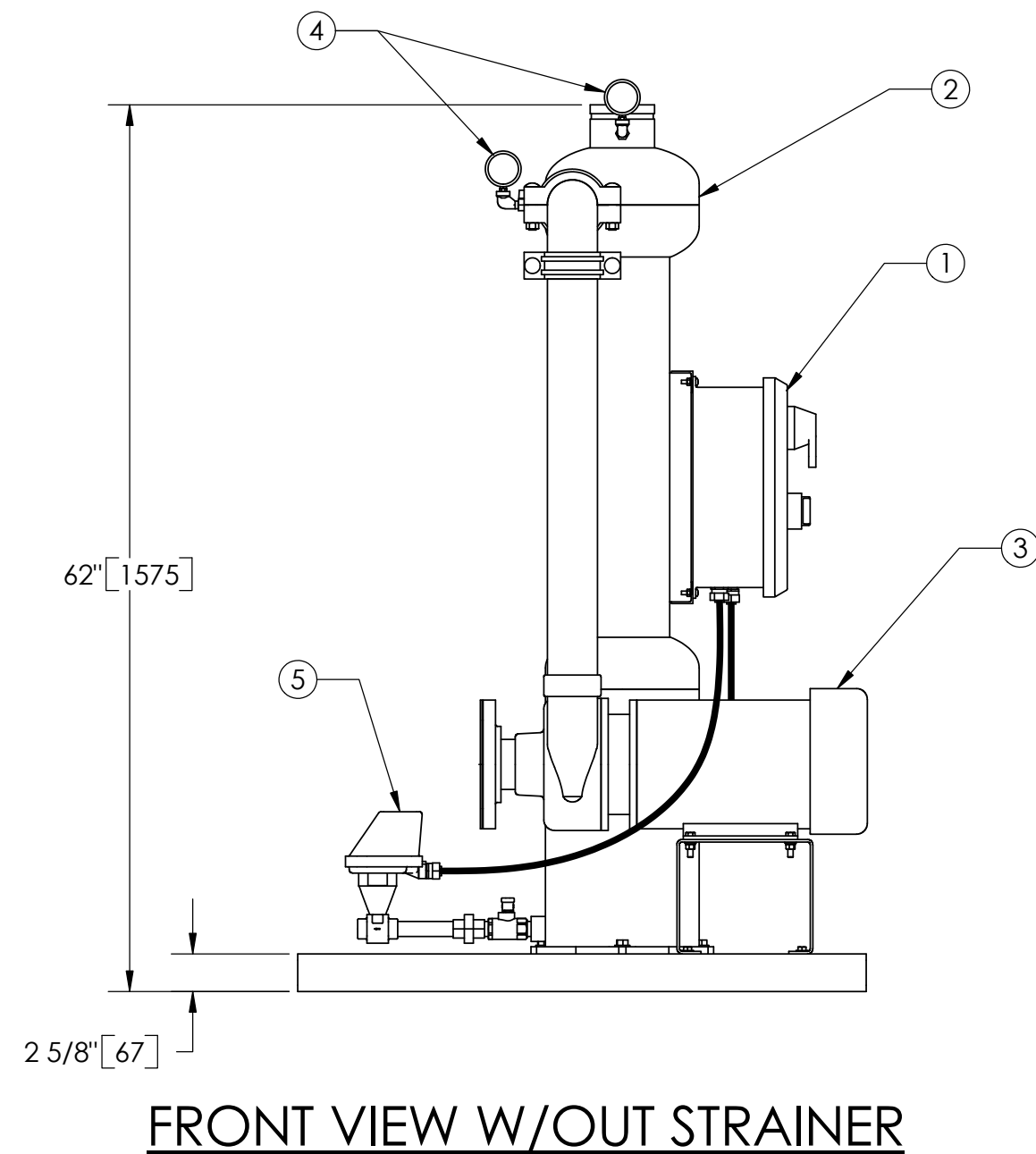

FRONT VIEW W/OUT STRAINER

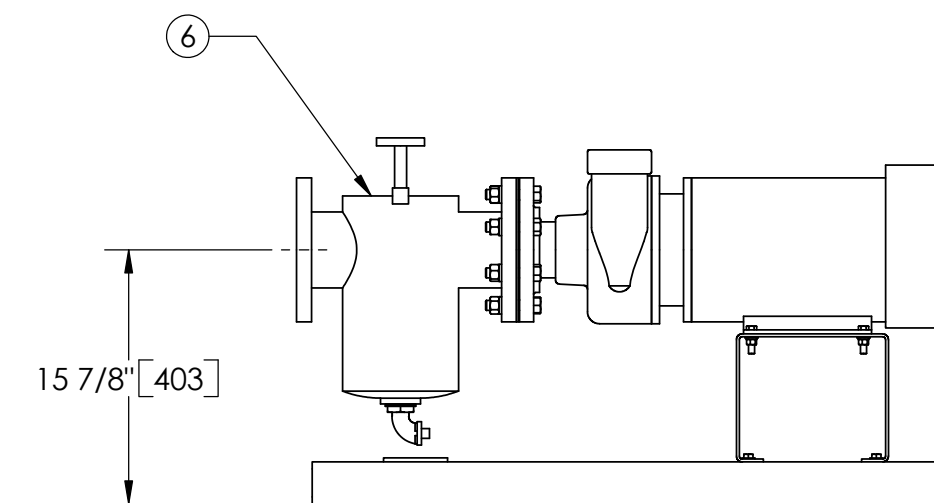

FRONT VIEW W/STRAINER

UNLESS OTHERWISE SPECIFIED: DIMENSIONS ARE IN: INCHES (mm) TOLERANCES ARE: FRACTIONS DECIMALS ANGLES ± 1/2" .XX ± .01 ± 1/4° .XXX ± .005 .XXXX ± .0005	ENGINEERED FOR: STANDARD	LAKOS CLAUDE LAVAL CORP. FRESNO, CALIFORNIA 93727 WWW.LAKOS.COM		LAKOS UNDERGROUND SURVEYS		
	APPROVALS	DATE	TITLE			
DO NOT SCALE DRAWING	DRAWN DLW	5/5/05	TCI-0280-CMBV, TC SYSTEM, SWEEPER ILB-0350, 460V 60HZ STD			
MATERIAL PER LAKOS SPEC	ENGR HSK	9/8/05				
FINISH AS ASSEMBLED	MFG -	-	SIZE C	MODEL NO.	DWG NO. 115438	REV. B
	WORK ORDER	QTY.	SCALE 1:12	EST. WT. 554 lb	SHEET 1 OF 1	

DWG NO. 115438 SHEET 1 REV. B