

EXCEPT AS OTHERWISE PROVIDED BY CONTRACT, THIS DRAWING AND SPECIFICATIONS SHALL NOT BE REPRODUCED, COPIED OR USED AS THE BASIS FOR MANUFACTURE OR SALE OF MATTER DEPICTED HEREIN WITHOUT THE EXPRESSED WRITTEN PERMISSION OF THE CLAUDE LAVAL CORPORATION, OR ITS ASSIGNEES.

REVISION HISTORY				
ZONE	REV	DESCRIPTION	DATE	APPROVED

THIS DRAWING HAS BEEN GENERATED AND IS MAINTAINED BY A CAD SYSTEM. CHANGES SHALL ONLY BE INCORPORATED AS DIRECTED BY AN APPROVED ENGINEERING CHANGE ORDER (ECO). PAPER COPIES ARE UNCONTROLLED.

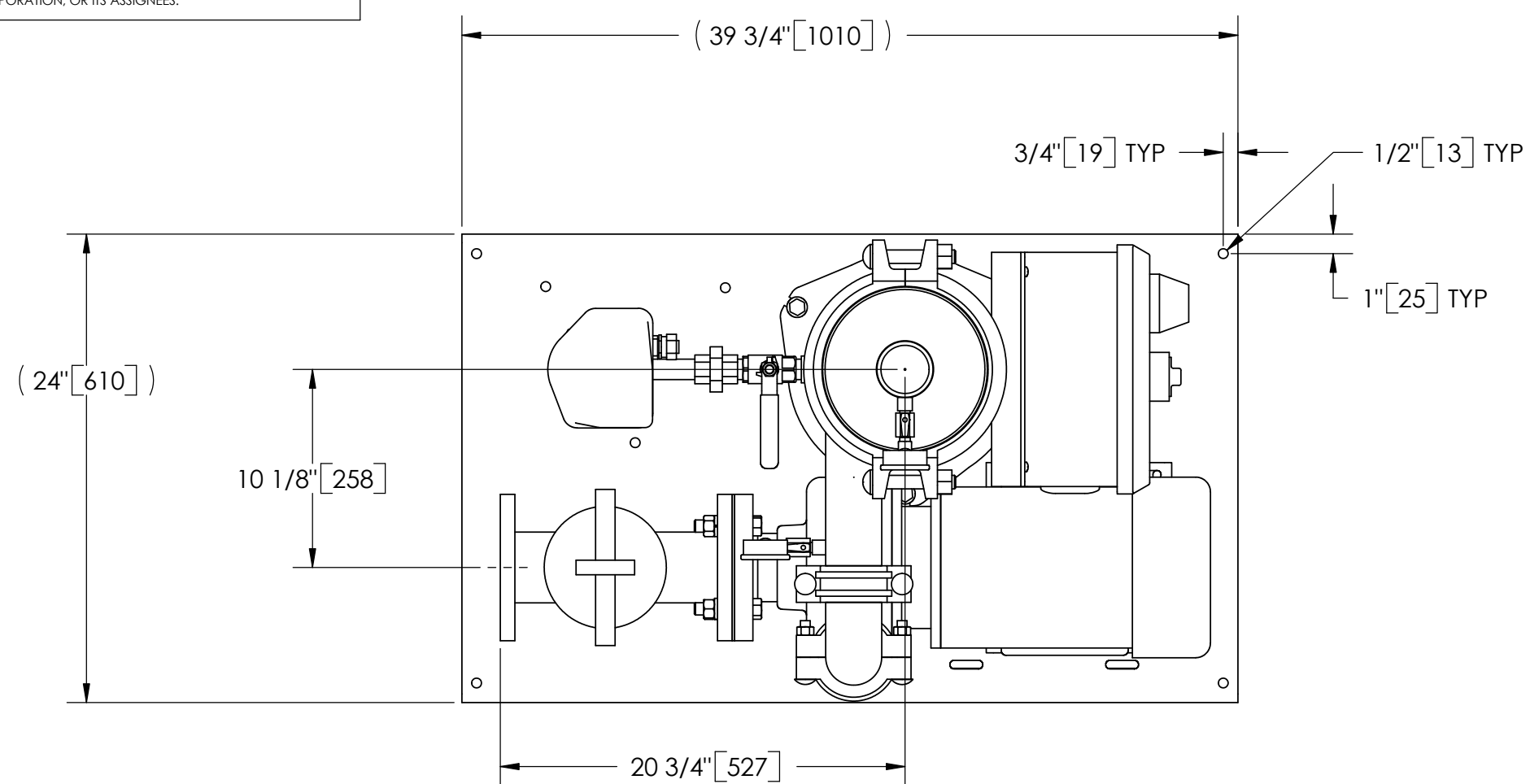

TOP VIEW

NOTES:

1. INLET IS 3" PIPE (125# ANSI FLANGED).
2. OUTLET IS 2-1/2" PIPE (GROOVED).
3. PURGE OUTLET IS 3/4" PIPE.
4. MAXIMUM PRESSURE: 150 psi (10.3 bar).
5. MAXIMUM TEMPERATURE: 100°F (37.8°C).
6. SPECIFIED FLOWRATE OF 145 gpm (33 m³/hr).
7. FINISH: AS ASSEMBLED.
8. POWER REQUIREMENT: 460V, 3PH, 60Hz.
9. NEMA 4X MOTOR STARTER ENCLOSURE WITH SAFETY DISCONNECT AND H.O.A. SWITCH.
10. APPROXIMATE DRY WEIGHT: 556 lbs (252 kg).
11. INLET/OUTLET VALVE KIT, MODEL TCV-0145 RECOMMENDED.
12. MINIMUM PIPE FROM TOWER BASIN TO TC SYSTEM IS 4" PIPE.
13. FLOODED SUCTION REQUIRED.

COMPONENT LIST:

- ① ELECTRICAL CONTROL BOX 460V 60Hz W/120V TRANSFORMER.
- ② SEPARATOR: HTX-0085.
- ③ PUMP: 5HP CENTRIFUGAL, 3500 rpm, 460V, 60Hz.
- ④ INLET/OUTLET PRESSURE GAUGES: 0-100 psi, GLYCERIN-FILLED.
- ⑤ PURGE EQUIPMENT: CMBV.
- ⑥ BASKET STRAINER.

SUBMITTAL DRAWING

This drawing is submitted for spatial consideration only. Do not pre-plumb to these dimensions.

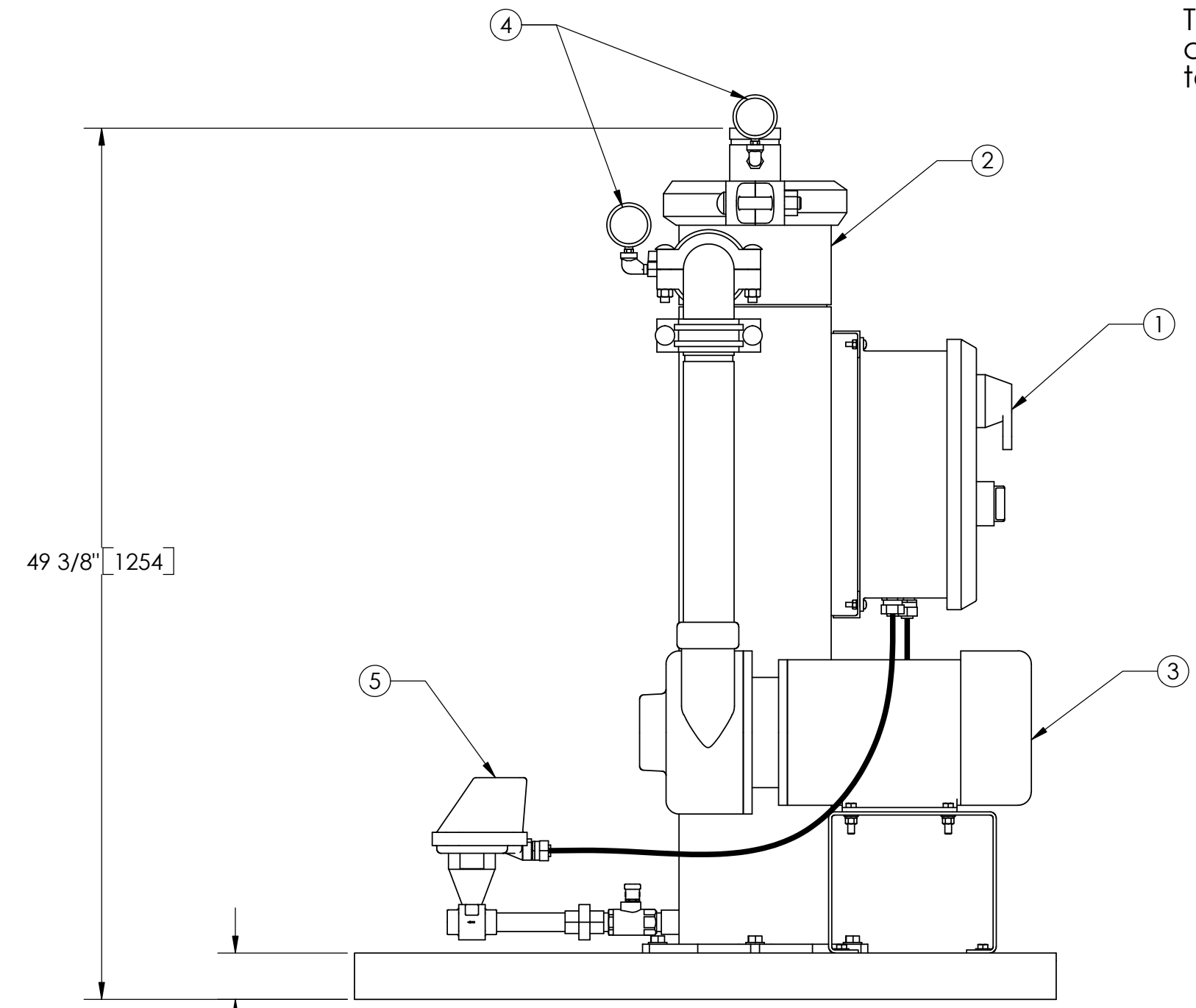

FRONT VIEW W/O STRAINER

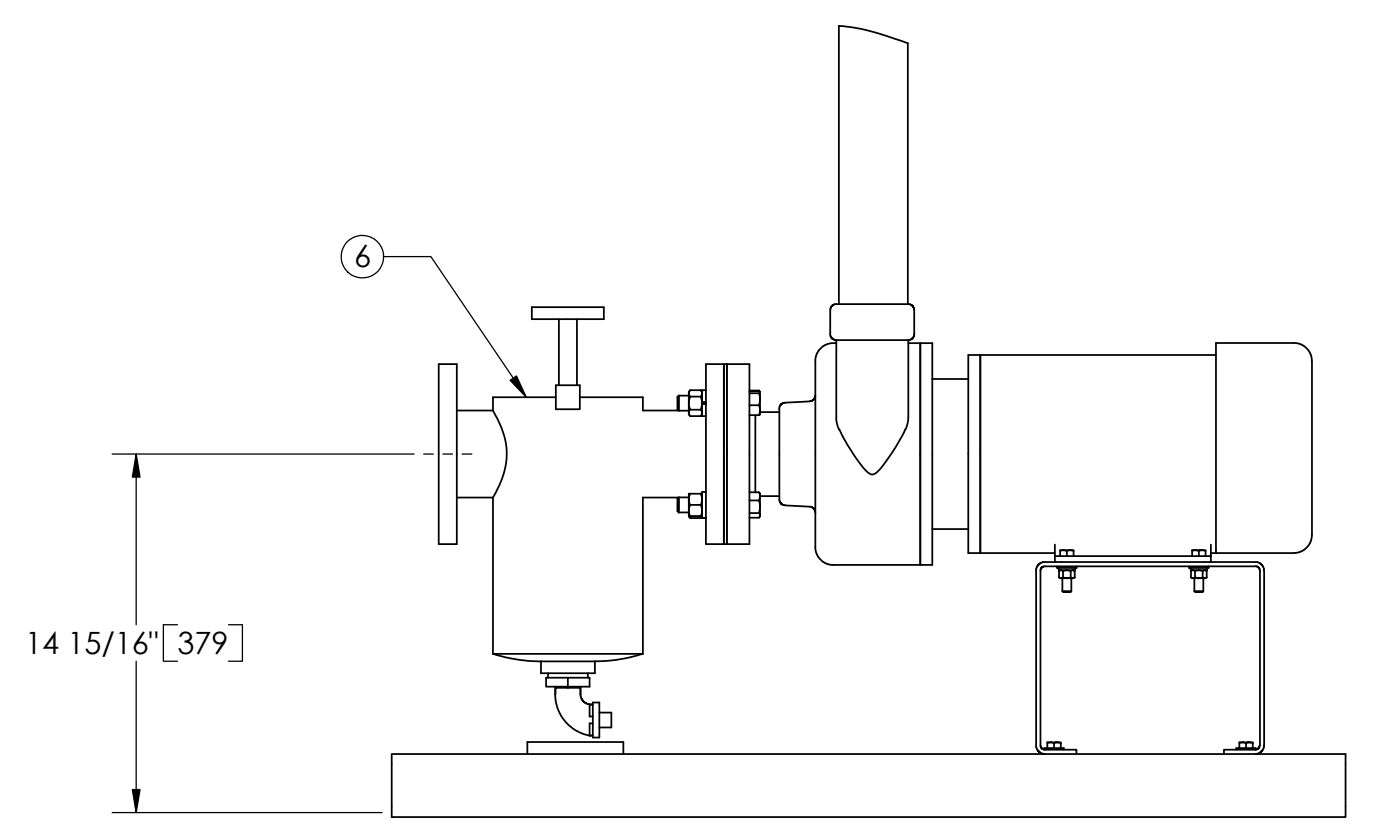

FRONT VIEW PUMP & STRAINER

UNLESS OTHERWISE SPECIFIED: DIMENSIONS ARE IN: INCHES (mm) TOLERANCES ARE: FRACTIONS DECIMALS ANGLES ± 1/2" .XX ± .01 ± 1/4" XXX ± .005 XXXX ± .0005	ENGINEERED FOR: STANDARD		CLAUDE LAVAL CORP. FRESNO, CALIFORNIA 93727 WWW.LAKOS.COM	LAVAL UNDERGROUND SURVEYS
	APPROVALS	DATE		
DO NOT SCALE DRAWING	DRAWN KFB/DLW	1/3/05	TITLE TCX-0145-CMBV, TC SYSTEM, SWEEPER HTX-0085, 460V 60HZ DELUXE	
MATERIAL SEE PARTS LIST	ENGR HSK	1/13/05		
FINISH AS ASSEMBLED	MFG -	-	SIZE C	MODEL NO.
	WORK ORDER	QTY.	DWG NO. 115445	REV. 01
			SCALE 1:8	EST. WT. 556 lb
			SHEET 1 OF 1	

DWG NO. 115445 SHEET 1 REV. 01