

EXCEPT AS OTHERWISE PROVIDED BY CONTRACT, THIS DRAWING AND SPECIFICATIONS SHALL NOT BE REPRODUCED, COPIED OR USED AS THE BASIS FOR MANUFACTURE OR SALE OF MATTER DEPICTED HEREIN WITHOUT THE EXPRESSED WRITTEN PERMISSION OF THE CLAUDE LAVAL CORPORATION, OR ITS ASSIGNEES.

THIS DRAWING HAS BEEN GENERATED AND IS MAINTAINED BY A CAD SYSTEM. CHANGES SHALL ONLY BE INCORPORATED AS DIRECTED BY AN APPROVED ENGINEERING CHANGE ORDER (ECO). PAPER COPIES ARE UNCONTROLLED.

REVISION HISTORY				
ZONE	REV	DESCRIPTION	DATE	APPROVED

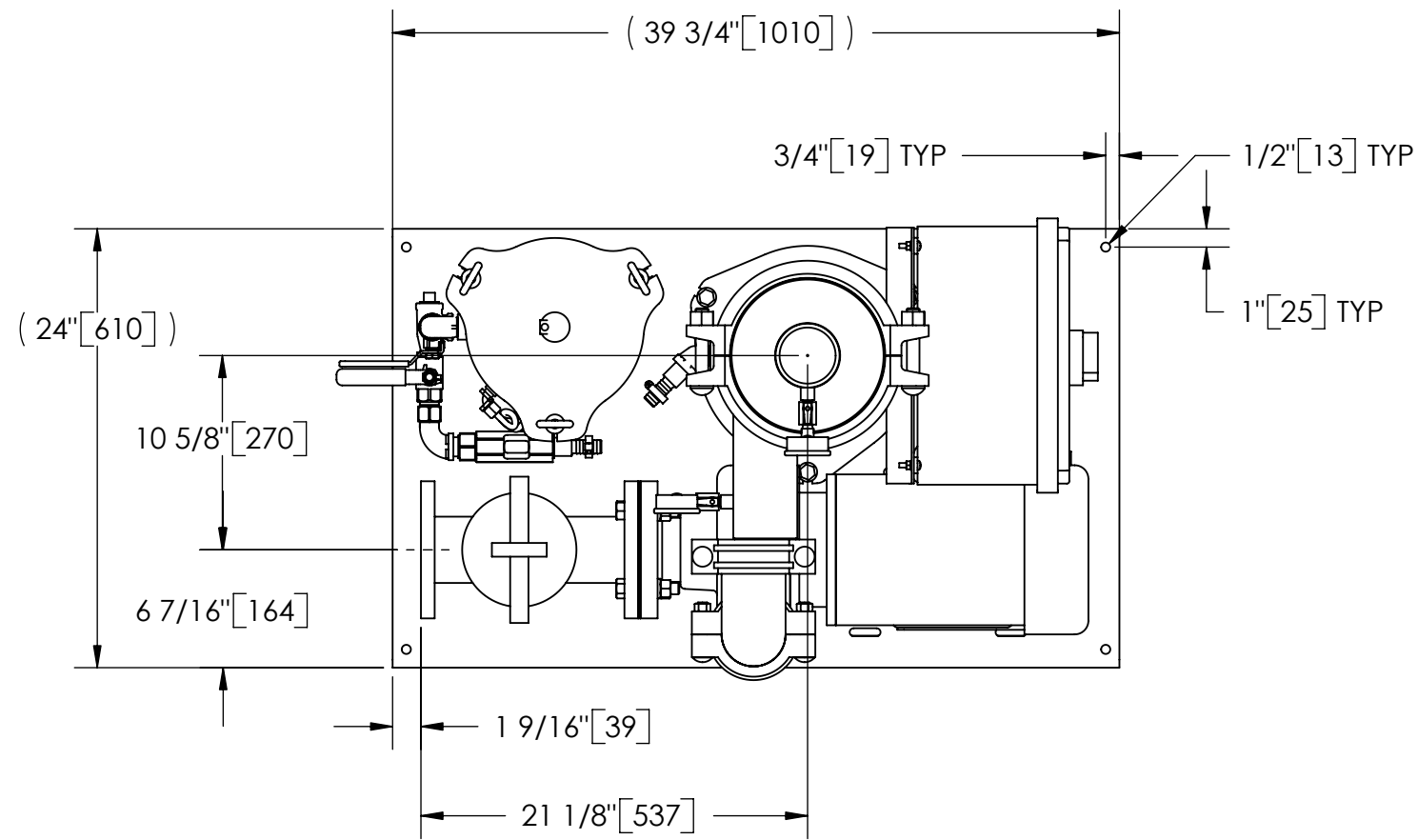

TOP VIEW

NOTES:

1. INLET IS 3" PIPE (125# ANSI FLANGED).
2. OUTLET IS 3" PIPE (GROOVED).
3. PURGE OUTLET IS 3/4" PIPE.
4. MAXIMUM PRESSURE: 150 psi (10.3 bar).
5. MAXIMUM TEMPERATURE: 100°F (37.8°C).
6. SPECIFIED FLOWRATE OF 200 gpm (45 m<sup>3</sup>/hr).
7. FINISH: AS ASSEMBLED.
8. POWER REQUIREMENT: 460V, 3PH, 60Hz.
9. NEMA 4X MOTOR STARTER ENCLOSURE WITH SAFETY DISCONNECT AND H.O.A. SWITCH.
10. APPROXIMATE DRY WEIGHT: 662 lbs (300 kg).
11. INLET/OUTLET VALVE KIT, MODEL TCV-0200 RECOMMENDED.
12. MINIMUM PIPE FROM TOWER BASIN TO TC SYSTEM IS 4" PIPE.
13. FLOODED SUCTION REQUIRED.

COMPONENT LIST:

- ① ELECTRICAL CONTROL BOX 460V 60Hz W/120V TRANSFORMER.
- ② SEPARATOR: HTX-0130-TC.
- ③ PUMP: 7-1/2 HP CENTRIFUGAL, 3500 rpm, 460V, 60Hz.
- ④ INLET/OUTLET PRESSURE GAUGES: 0-100 psi, GLYCERIN-FILLED.
- ⑤ PURGE EQUIPMENT: SRV-816.
- ⑥ DIFFERENTIAL PRESSURE INDICATOR: (AVAILABLE WITH DRY DRY CONTACT-MODEL DHE-15-S. ORDER SEPARATELY).
- ⑦ BASKET STRAINER.

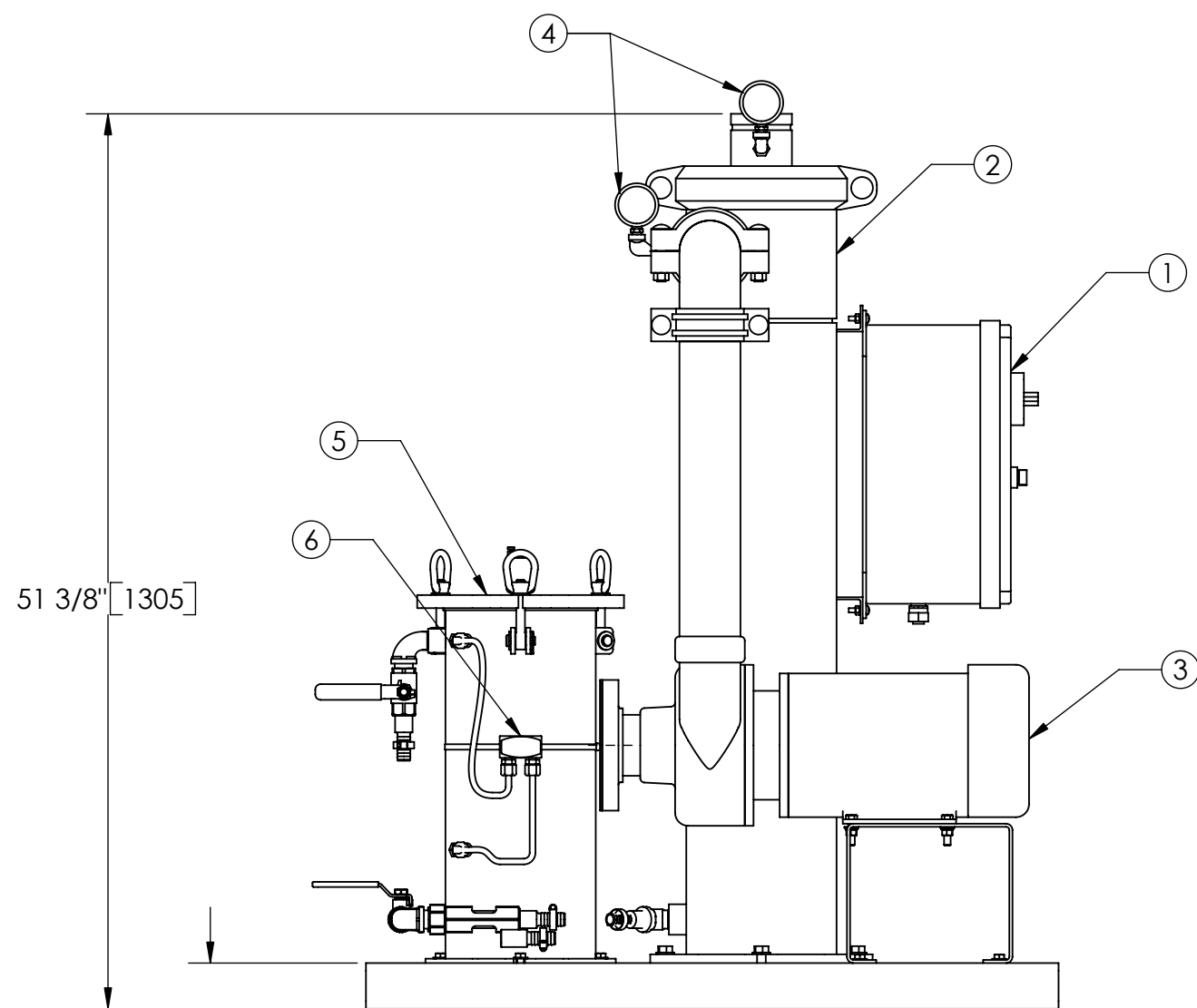

FRONT VIEW W/OUT STRAINER

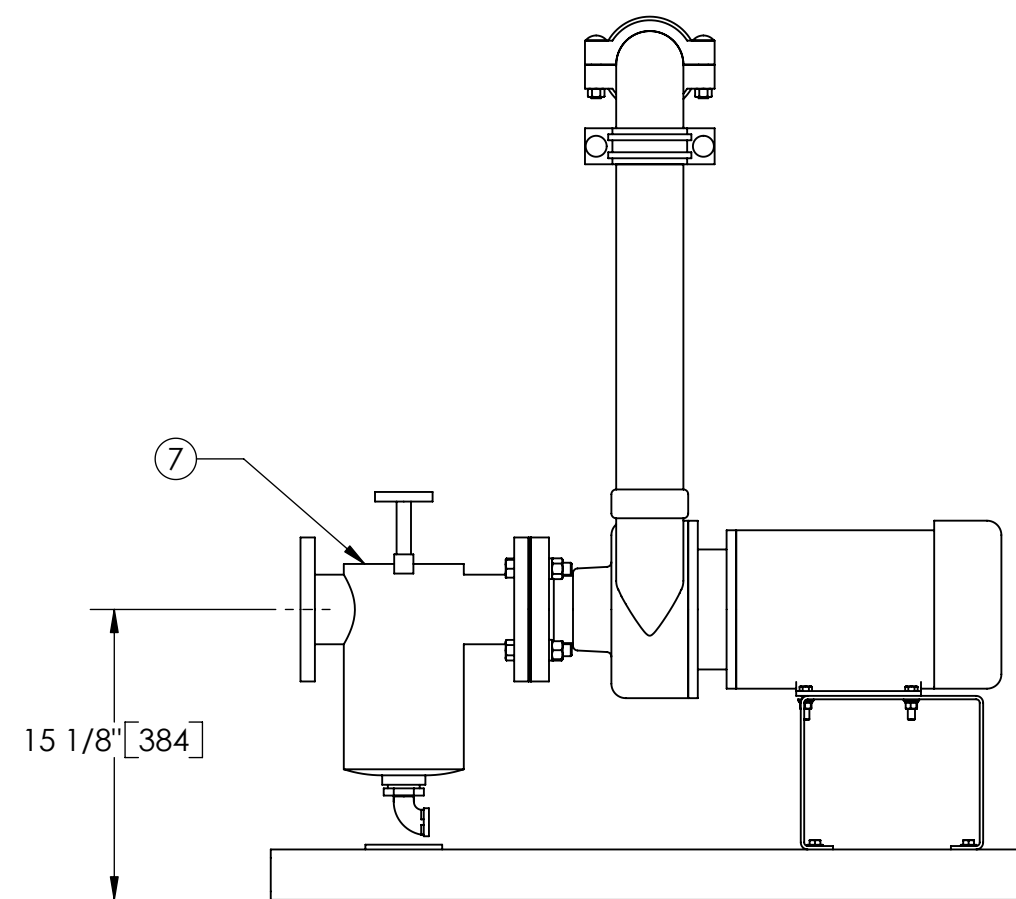

FRONT VIEW W/STRAINER

SUBMITTAL DRAWING

This drawing is submitted for spatial consideration only. Do not pre-plumb to these dimensions.

UNLESS OTHERWISE SPECIFIED: DIMENSIONS ARE IN: INCHES [mm] TOLERANCES ARE: FRACTIONS    DECIMALS    ANGLES ± 1/2"        .XX ± .01        ± 1/4° .XXX ± .005 .XXXX ± .0005			ENGINEERED FOR: <b>STANDARD</b>		CLAUDE LAVAL CORP. FRESNO, CALIFORNIA 93727 WWW.LAKOS.COM		LAVAL UNDERGROUND SURVEYS	
DO NOT SCALE DRAWING			APPROVALS	DATE	TITLE			
MATERIAL PER LAKOS SPEC			DRAWN GMB/HSK	7/21/05	TCX-0200-SRV, TC SYSTEM SWEEPER HTX-0130, 460V 60HZ DELUXE			
FINISH AS ASSEMBLED			ENGR HSK		SIZE C	MODEL NO.	DWG NO. <b>115428</b>	REV. C
			WORK ORDER	QTY.	SCALE 1:12	EST. WT. 662 lb	SHEET 1 OF 1	

DWG. NO. 115428