

EXCEPT AS OTHERWISE PROVIDED BY CONTRACT, THIS DRAWING AND SPECIFICATIONS SHALL NOT BE REPRODUCED, COPIED OR USED AS THE BASIS FOR MANUFACTURE OR SALE OF MATTER DEPICTED HEREIN WITHOUT THE EXPRESSED WRITTEN PERMISSION OF THE CLAUDE LAVAL CORPORATION, OR ITS ASSIGNEES.

THIS DRAWING HAS BEEN GENERATED AND IS MAINTAINED BY A CAD SYSTEM. CHANGES SHALL ONLY BE INCORPORATED AS DIRECTED BY AN APPROVED ENGINEERING CHANGE ORDER (ECO). PAPER COPIES ARE UNCONTROLLED.

| REVISION HISTORY | | | | |
|------------------|-----|-----------------------------------|---------|----------|
| ZONE | REV | DESCRIPTION | DATE | APPROVED |
| - | A | REMOVED ELBOW AND UPDATED DRAWING | 2/18/03 | NAC |

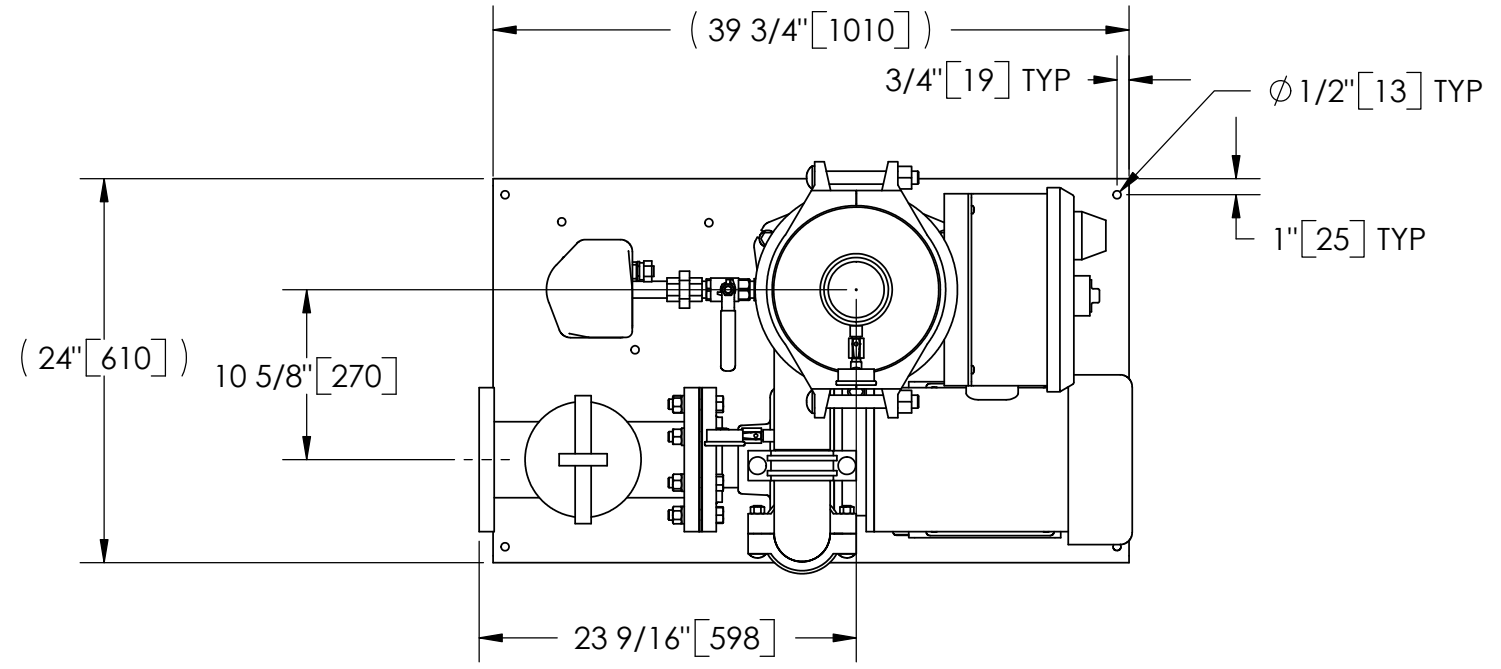

TOP VIEW

SUBMITTAL DRAWING

This drawing is submitted for spatial consideration only. Do not pre-plumb to these dimensions.

NOTES:

1. INLET IS 4" PIPE (125# ANSI FLANGED).
2. OUTLET IS 4" PIPE (GROOVED).
3. PURGE OUTLET IS 3/4" PIPE.
4. MAXIMUM PRESSURE: 150 psi (10.3 bar).
5. MAXIMUM TEMPERATURE: 100°F (37.8°C).
6. SPECIFIED FLOWRATE OF 280 gpm (64 m³/hr).
7. FINISH: AS ASSEMBLED.
8. POWER REQUIREMENT: 460V, 3PH, 60Hz.
9. NEMA 4X MOTOR STARTER ENCLOSURE WITH SAFETY DISCONNECT AND H.O.A. SWITCH.
10. APPROXIMATE DRY WEIGHT: 728 lbs (330 kg).
11. INLET/OUTLET VALVE KIT, MODEL TCV-0280 RECOMMENDED.
12. MINIMUM PIPE FROM TOWER BASIN TO TC SYSTEM IS 6" PIPE.
13. FLOODED SUCTION REQUIRED.

COMPONENT LIST:

- ① ELECTRICAL CONTROL BOX 460V 60Hz W/115V TRANSFORMER.
- ② SEPARATOR: HTX-0200-TC.
- ③ PUMP: 10 HP CENTRIFUGAL, 3500 rpm, 460V, 60Hz.
- ④ INLET/OUTLET PRESSURE GAUGES: 0-100 psi, GLYCERIN-FILLED.
- ⑤ PURGE EQUIPMENT: CMBV-07-120V.
- ⑥ BASKET STRAINER.

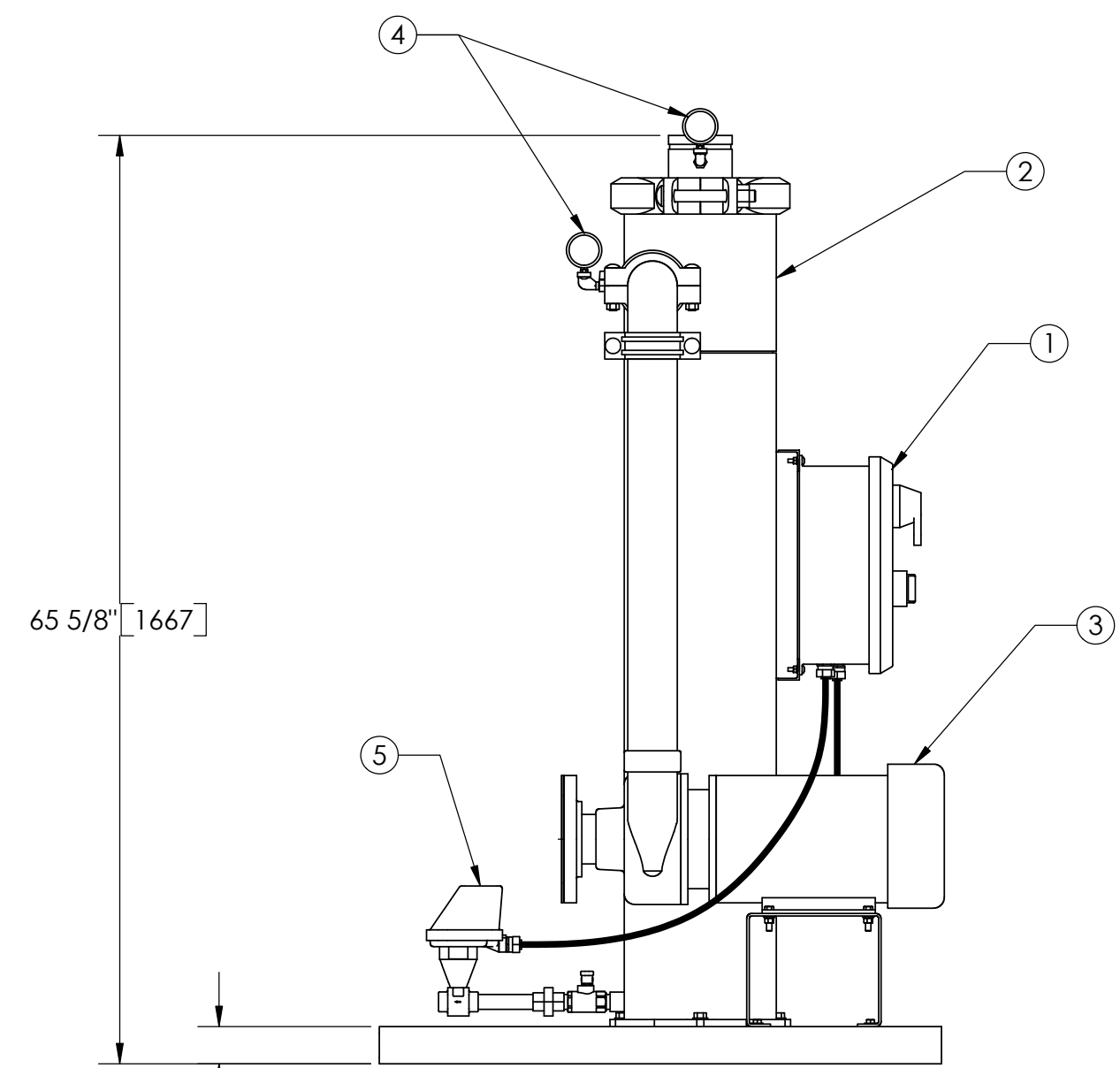

FRONT VIEW W/OUT STRAINER

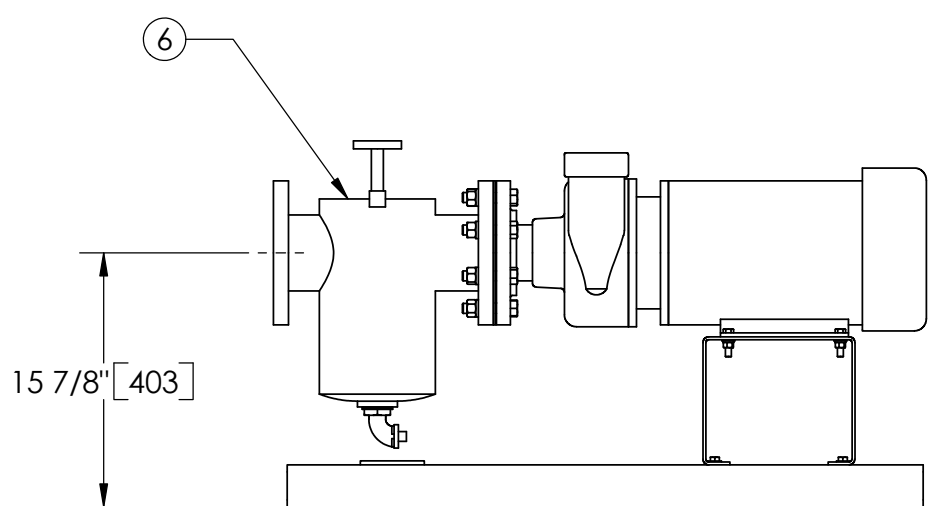

FRONT VIEW W/STRAINER

| | | | | | | | |
|--|------------------------------------|-----------|---------------|--|---|--|-----------|
| <small>UNLESS OTHERWISE SPECIFIED: DIMENSIONS ARE IN: INCHES [mm] TOLERANCES ARE: FRACTIONS DECIMALS ANGLES ± 1/2" .XX ± .01 ± 1/4" .XXX ± .005 .XXXX ± .0005</small> | ENGINEERED FOR: STANDARD | | | <small>CLAUDE LAVAL CORP. FRESNO, CALIFORNIA 93727 WWW.LAKOS.COM</small> | | | |
| | DO NOT SCALE DRAWING | APPROVALS | | DATE | TITLE | | |
| | MATERIAL PER LAKOS SPEC | ENGR | | 9/8/05 | TCX-0280-CMBV, TC SYSTEM, SWEEPER HTX-0200, 460V 60HZ DELUXE | | |
| | FINISH AS ASSEMBLED | MFG | | - | SIZE C | | MODEL NO. |
| | WORK ORDER | | SCALE 1:12 | EST. WT. 728 lb | SHEET 1 OF 1 | | |

DWG NO. 115447 SHEET 1 REV. A