

Application Bulletin

LAKOS Filters Brine Water in Salt Dome Mining Application

Application:	Salt Dome Mining in Beaumont, Texas
System Identification:	LAKOS Super Separators (Three Stage JPX System)
Solids:	Sand
Liquid:	Brine Water
Problem/Challenge:	To effectively remove sand from brine water, which is a by-product of mining. After the sand is removed the brine water will be reinjected into disposal wells.

Problem: PB Energy in Beaumont, Texas is preparing a cavern in a salt dome so it can be used to store natural gas. Removing the salt results in a heavy brine water mixed with sand. The sand must be removed prior to reinjecting the brine water into disposal wells so those wells do not clog, thereby creating the need for drilling more wells than needed.

Solution: The LAKOS solution is three LAKOS Super Separator units. Each unit combines three LAKOS JPX Separators into a combined filtration system, (9 LAKOS Separators total) and is used to separate sand from the brine water. They are installed into the system at the full stream rate of 800 - 5000 US gallons per minute (182-1136 m³/hr) and 80 psi (5.52 bar). See photo on next page. Each LAKOS Separator is equipped with a pneumatic pinch valve that is set to purge the removed sand at set times into a concrete purge holding pit. The pits are cleaned out later as needed.

Other possible solutions which were rejected in favor of the LAKOS Super Separators include:

- Screens were considered, but their typical high maintenance would increase labor costs. Separators can operate for long periods without needing any maintenance.

(Continued on reverse)

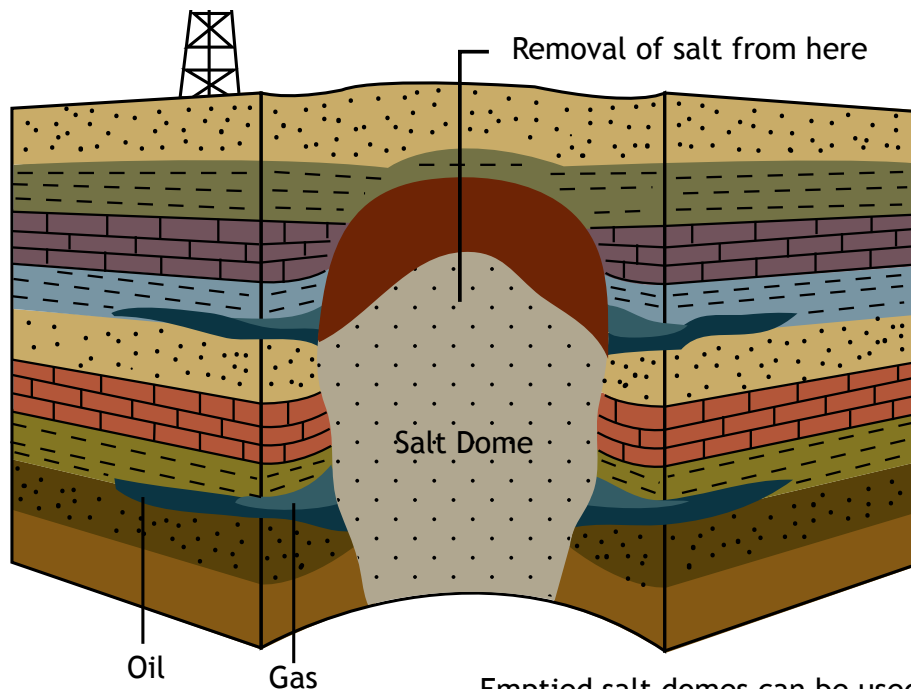

Emptied salt domes can be used to store natural gas, etc.



- Settling ponds were used in the past, in which the sand eventually sank to the bottom. But they took up a lot of land space, they sometimes overflowed and often made a mess.

Since installing the LAKOS Super Separator system, the entire system is running without routine maintenance. The end-users greatly appreciate the positive impact that it is making on their system -- efficiency and cost effectiveness.

Above: Three (3) LAKOS Super Separators in series (JPX models)
 Below: Piping diagram and illustration of purge pit disposal area

PIPING DIAGRAM OF PURGE PIT DISPOSAL AREA

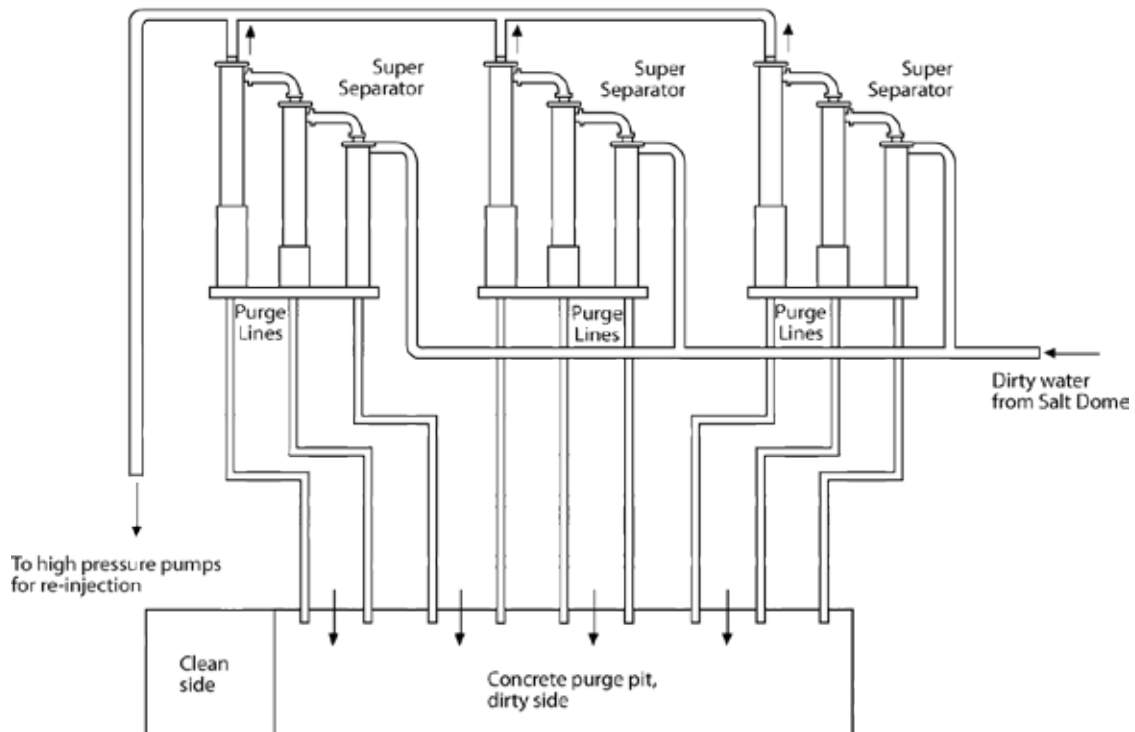

CLAUDE LAVAL CORPORATION

Not connected with The DeLaval Separator Company

1365 N. Clovis Avenue • Fresno, California 93727 USA

Telephone: (559) 255-1601 • Fax: (559) 255-8093

Toll-Free: (800) 344-7205 (USA, Canada & Mexico)

www.lakos.com • E-mail: info@lakos.com