

# SST Series Sand Media Filtration Systems

## Installation and Operation Instructions

**THIS MANUAL TO BE LEFT WITH THE END-USER**



LAKOS SST Systems are available with an optional skid mount assembly. Consult factory for details.

### TABLE OF CONTENTS

Recommended Accessories .....	Page 2	Assembling The Components .....	7
Introduction .....	3	Automatic Controller Configuration .....	8
Basics of Operation .....	4	Start-Up Procedures .....	9
General Specifications .....	5	Periodic/Mid-Season Maintenance .....	9
Materials of Construction .....	5	Seasonal Shutdown Procedures .....	10
Media Sand Options .....	6	Backwash Repair Recommendations .....	11
Site Preparations .....	6	Troubleshooting .....	13
Pre-Installation Checklist .....	6	APPENDIX	
Filter System Installation .....	7	Kits and Spare Parts Listing, Form LS-695	

## Before You Begin....

**CAUTION:** Water sources vary and may contain impurities that can adversely affect a filter system. Minerals, biological microbes and other impurities must be identified and addressed by each user on a case-by-case basis. Adhere to seasonal shutdown recommendations to minimize problems. Contact your irrigation system dealer for additional information and further recommendations.

**CAUTION:** It is common to inject chemicals and/or liquid fertilizers into a drip/micro irrigation system. Such injection is recommended after the filter system to minimize potential deterioration and/or damage to the filter tanks and/or other filter system components.

### Recommended Accessories

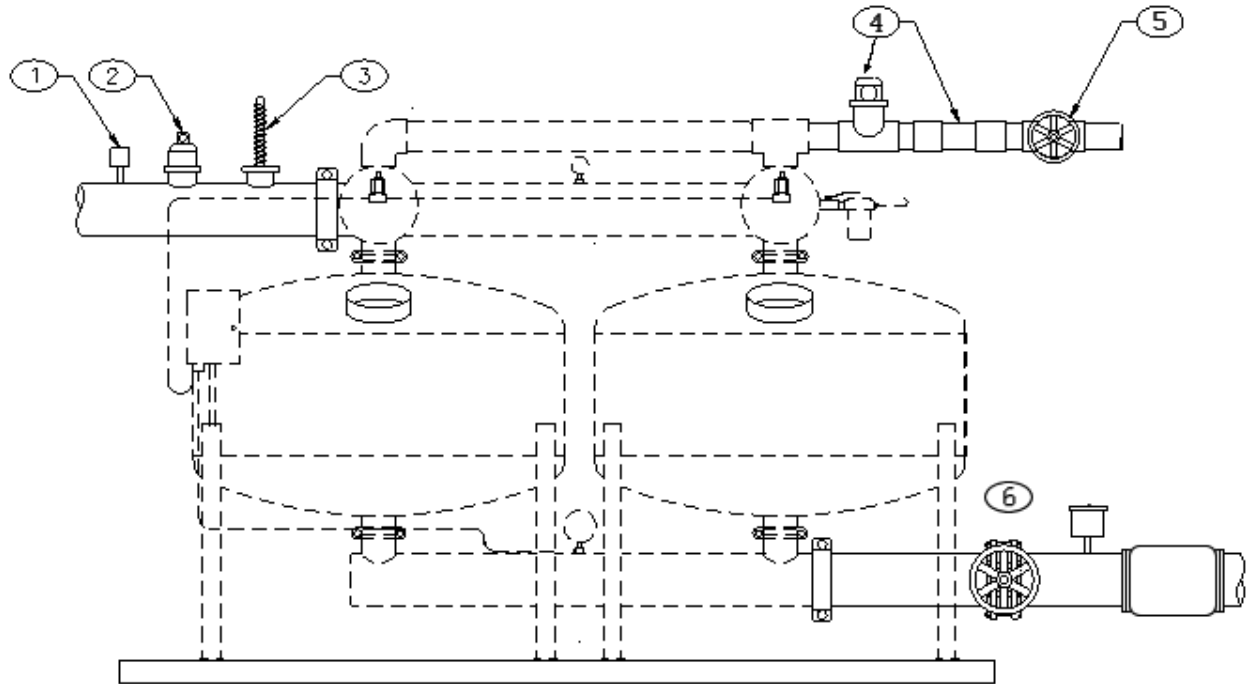

The following items are **NOT** included with your LAKOS SST Filter System. Consider the need and use your judgement for adding to your system.

- 1. High pressure shut-off switch**  
Installed on inlet, pre-set at maximum operating pressure of the filter system.
- 2. Air vents**  
Should be installed at highest points in the manifolds to bleed trapped air from the system.
- 3. Pressure relief vents**  
These will protect the filter system from excess spikes in pressure or water hammer.
- 4. Backwash sightglass/view-tube** (available as an option from LAKOS)  
Provides visual verification that backwash is in progress and operating at proper flow rate.
- 5. Backwash line throttling valve**  
This valve helps ensure the proper backwash flow is maintained. See Start-Up Procedures, page 10.
- 6. Pressure-Sustaining valve**  
Either manual or automatic valve to ensure adequate flow during backwash. Restricts downstream flow to direct necessary flow/pressure for backwashing.

**For Additional Kits and Spare Parts:  
Refer to the stapled literature set # LS-695 for SST Sand Media Kits**

## Introduction

LAKOS Systems set the industry standards for operating performance and efficiency. Please read this manual carefully to ensure the best performance possible for your system. This manual contains information regarding assembly, start-up, seasonal shut-down, maintenance and troubleshooting. Keep this document for future use and reference. Should you have any questions or concerns, contact your LAKOS representative for further assistance.

LAKOS Sand Media Filtration Systems are designed for use with drip/micro irrigation systems to keep unwanted particle matter out of the irrigation system. Media filtration is recommended when the contaminants are lightweight in nature, such as algae, organics, silt, etc. For heavy sand particles, which may not backwash during normal operation, consider a LAKOS Sand Separator as a pre-filter to prevent excess accumulation of sand particles on the sand media.

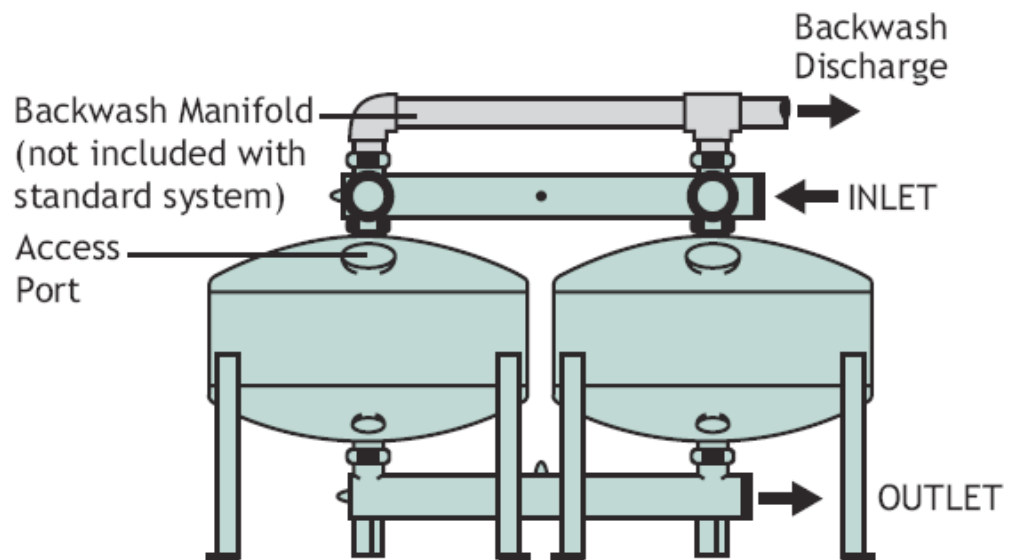

The exclusive LAKOS Underdrain provides that only one grade of media sand is required. No need for a coarse gravel pack, since the LAKOS Underdrain is a full-coverage pattern, enabling backwash water to immediately flow upward from the underdrain to uniformly and completely flush the entire media bed depth and surface area.

LAKOS Underdrain

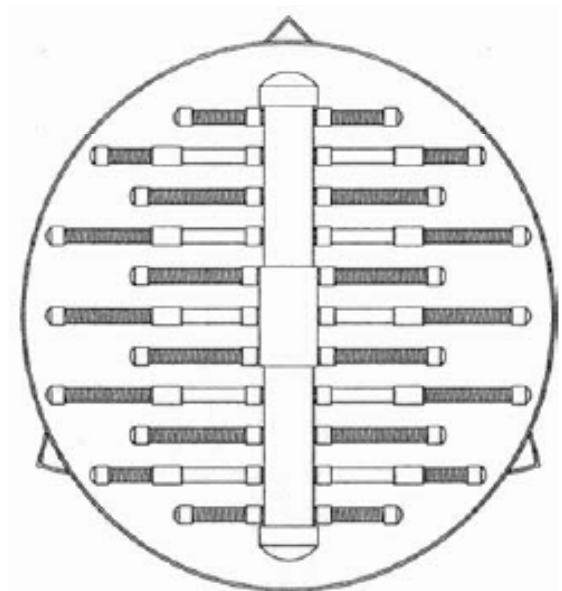

## Basics of Operation

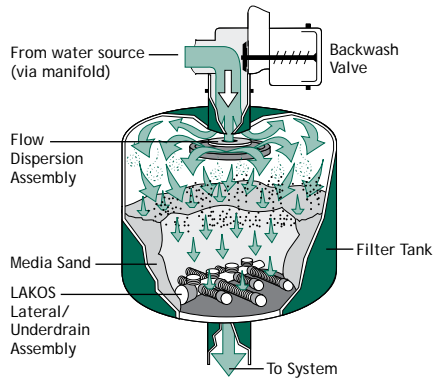

### The Filtering Process

The filtering process engages the use of a specified sand media to trap foreign matter on the surface layer, allowing filtered water to percolate through the sand media and LAKOS internal v-slotted lateral assembly, discharging at the bottom of each tank to the outlet manifold.

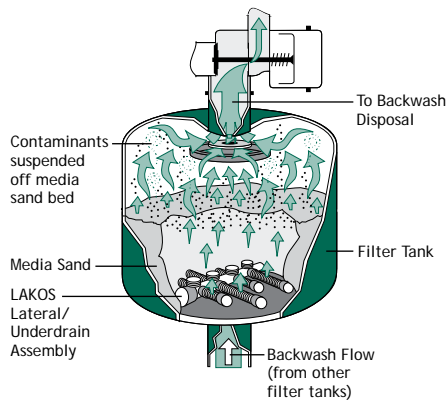

### The Backwash Cycle

The backwash cycle flushes trapped debris from the sand media and out of the filter tanks. Each tank in a LAKOS System is flushed individually for maximum agitation of the sand media. Triggered by pressure differential, by elapsed time or manually, each tank's backwash valve is alternately activated into the backwash mode, which simultaneously interrupts inlet flow to that particular tank. Overall system pressure then directs partial system flow back into and through the tank's lateral assembly.

Flow continues for a prescribed period of time (typically one minute), suspending the foreign matter and carrying it out through the tank's top port (normal inlet) and out through the backwash valve and piping. The backwash valve then returns to its original position and restores the now "clean" filter tank to normal service.

*NOTE: The LAKOS automatic controller provides a variable time delay between stations to avoid overlapping backwash cycles and maximize backwash efficiency.*



## General Specifications

Model *	Flow Range*		Recommended Backwash Flow Rate Per Tank		Media Sand Requirement (complete system)		Maximum Filter Tank Pressure		Minimum Backwash Line
	U.S. gpm	m <sup>3</sup> /hr.	U.S. gpm	m <sup>3</sup> /hr.	lbs.	kg	psi	bar	Size
SST-1503-2 A/I	44-60	10-14	18	4.1	300	181	100	7.0	3-inch
SST-1803-2 A/I	60-90	14-20	27	6.1	500	227	100	7.0	3-inch
SST-1803-3 A/I	95-135	22-31	27	6.1	750	340	100	7.0	3-inch
SST-2403-2 A/I	112-160	25-36	47	10.7	900	408	100	7.0	3-inch
SST-2404-3 A/I	165-235	37-53	47	10.7	1350	612	100	7.0	3-inch
SST-3004-2 A/I	180-250	41-57	74	16.8	1000	454	100	7.0	3-inch
SST-3004-3 A/I	270-375	62-86	74	16.8	1500	680	100	7.0	3-inch
SST-3006-3 A/I	270-375	62-86	74	16.8	1500	680	100	7.0	3-inch
SST-3604-2 A/I	260-350	59-80	106	24.1	1800	816	100	7.0	3-inch
SST-3606-2 A/I	260-350	59-80	106	24.1	1800	816	100	5.6	3-inch
SST-3606-3 A/I	375-525	86-120	106	24.1	2700	1225	100	5.6	3-inch
SST-4806-2 A/I	440-625	100-142	188	42.7	2600	1179	80	5.6	4-inch
SST-4806-3 A/I	650-940	148-213	188	42.7	3900	1769	80	5.6	4-inch
SST-4808-4 A/C	845-1240	192-282	188	42.7	5200	2358	80	5.6	4-inch
SST-4808-4 A/I	845-1240	192-282	188	42.7	5200	2358	80	5.6	4-inch
SST-4810-5 A/C	1050-1550	238-352	188	42.7	6500	2948	80	5.6	4-inch
SST-4810-5 A/I	1050-1550	238-352	188	42.7	6500	2948	80	5.6	4-inch
SST-4810-6 A/C	1270-1870	288-425	188	42.7	7800	3538	80	5.6	4-inch
SST-4810-6 A/H	1270-1870	288-425	188	42.7	7800	3538	80	5.6	4-inch
SST-4810-6 A/U	1270-1870	288-425	188	42.7	7800	3538	80	5.6	4-inch
SST-4810-7 A/C	1540-2185	350-495	188	42.7	9100	4128	80	5.6	4-inch
SST-4810-7 A/H	1540-2185	350-495	188	42.7	9100	4128	80	5.6	4-inch
SST-4810-8 A/H	1760-2495	400-565	188	42.7	10400	4717	80	5.6	4-inch
SST-4812-8 A/H	1760-2495	400-565	188	42.7	10400	4717	80	5.6	4-inch
SST-4812-9 A/H	1980-2810	450-640	188	42.7	11700	5307	80	5.6	4-inch
SST-4812-10 A/H	2200-3120	500-710	188	42.7	13000	5897	80	5.6	4-inch

Note: Recommended operating pressure range for proper actuation of LAKOS Backwash Valve is 20-80 psi (1.4 - 5.5 bar).  
**The stated flow range is based on a filtration range of 18-25 gpm/ft.<sup>2</sup> (49-61 m<sup>3</sup>/hr/m<sup>2</sup>). Select a larger model if the water has an above-average quantity of particulate or organics.**

## Materials of Construction

**Filter Tanks:** 304L certified stainless steel; with 8 inch size, epoxy-coated steel bolt-on top inspection port and 4-inch size lower-dome sand clean-out port & PVC plastic plug. 14 gauge wall thickness.

**Manifolds:** 304L stainless steel, grooved-end connections. 14 gauge wall Thickness.

**Backwash Valves:** Cast steel body with epoxy coated internals. Rear-entry feature for inspection/ replacement of plunger diaphragm. Stainless steel shaft & guide bushing (3-inch valve: PVC guide bushing). Stainless steel disc with vulcanized rubber to seal the backwash port.

**Controller:** Alex-tronix brand. Solid-state timing. Available in standard 110 volt AC or 220 volt AC, solar panel or 12-volt DC battery power options. Note: Two-station controllers (F2) are housed in a plastic unit. All other models are in steel housings.

(continued on next page)

LAKOS Underdrain

**LAKOS Underdrain:** The design of this pattern (see drawing on page 3 and photo at right) results in a uniform flow-through and backwash characteristic to most efficiently filter the water and backwash each filter tank. Only one grade of media sand is required; no need for a coarse gravel pack around the underdrain.

**The Header material** is schedule 40 PVC, with plastic wedgewire screen material as the open area component; minimum 135 psi (9.3) collapse strength. Open slotting is internally v-slotted (narrow on the exterior surface, wider on the interior surface – providing a nozzle effect to more effectively introduce water into the tank during backwashing. Open slot size is 0.010 inch in the slotted material. Overall, the open area of the LAKOS underdrain is approximately four times greater than the inlet/outlet size of the filter tank, providing no pressure loss through the filter (without sand). When sand is added to the filter tanks, a clean sand operating pressure loss of 1-2 psi is to be expected (assuming media sands of #12 – #20 size).

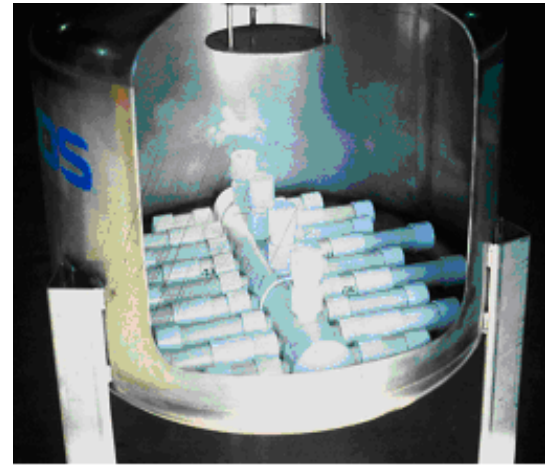

## Media Sand Options

Required media sand is not included with standard systems, but is available from LAKOS. Only one grade of sand media is necessary with any LAKOS system -- no coarse gravel base layer is required. The following sand grades are typically chosen for drip/micro irrigation purposes:

Media Grade	Sand Size Specifications
#20 Crushed Silica	200-250 mesh; 75 micron size
#16 Crushed Silica	150-200 mesh; 105 micron size
#12 Crushed Silica	130-140 mesh; 150 micron size

## Site Preparations

A level concrete pad is recommended for placement of the LAKOS SST System. Position the pad and the filter system for the most efficient placement of piping from the pump to the irrigation system and the backwash line. Minimize the number of elbows and changes in elevation to and from the filter system.

All electrical work and components should meet all applicable codes. Protect all wires and electrical components from moisture.

## Pre-Installation Checklist

- Inventory that all parts are included with the system. See Page 2 for Recommended Accessories.
- Check inside each filter tank to be sure no foreign objects or debris are present in the tanks. Verify that the underdrain is in place securely with no damage. Be sure the lower-dome clean-out port is securely tightened.
- Check all grooved-end connections for any damage that could hinder proper assembly.

## Filter System Installation

Align the filter tanks for easy access to the top access and lower-dome clean-out ports; consider the placement of the manifolds and other components. Attach the backwash valves to each tank securely with couplings, using proper lubricant on the gaskets. Be sure that valves are installed with proper connection to the tanks.

Attach the inlet, outlet and backwash manifolds with grooved-end couplings. Note: Backwash line is not provided by LAKOS.

**IMPORTANT:** The common practice of injecting fertilizers or chemicals should be piped into the system line *downstream of the filter system*. Some chemicals can be aggressive and harm or compromise the components of your filter system, reducing the life of your filter system.

Using the top access port, add the proper volume of media sand to each tank (refer to the Specification chart on page 5). It is recommended that media sand be added slowly and with some water in the tank to better insure that the sand properly beds both below and around the underdrain. Proper volume of sand will fill each tank to approximately 2/3 level.

## Assembling The Components

The following diagrams illustrate the proper assembly of the various parts of your LAKOS Filter System. Note that setting up an automatic system requires a longer setup and configuration time.

With either system, use proper care with the barbed tubing fittings to avoid damage/leaking problems. NOTE: Kit Assembly detail can be found in the LS-695 Spare Parts Listing.

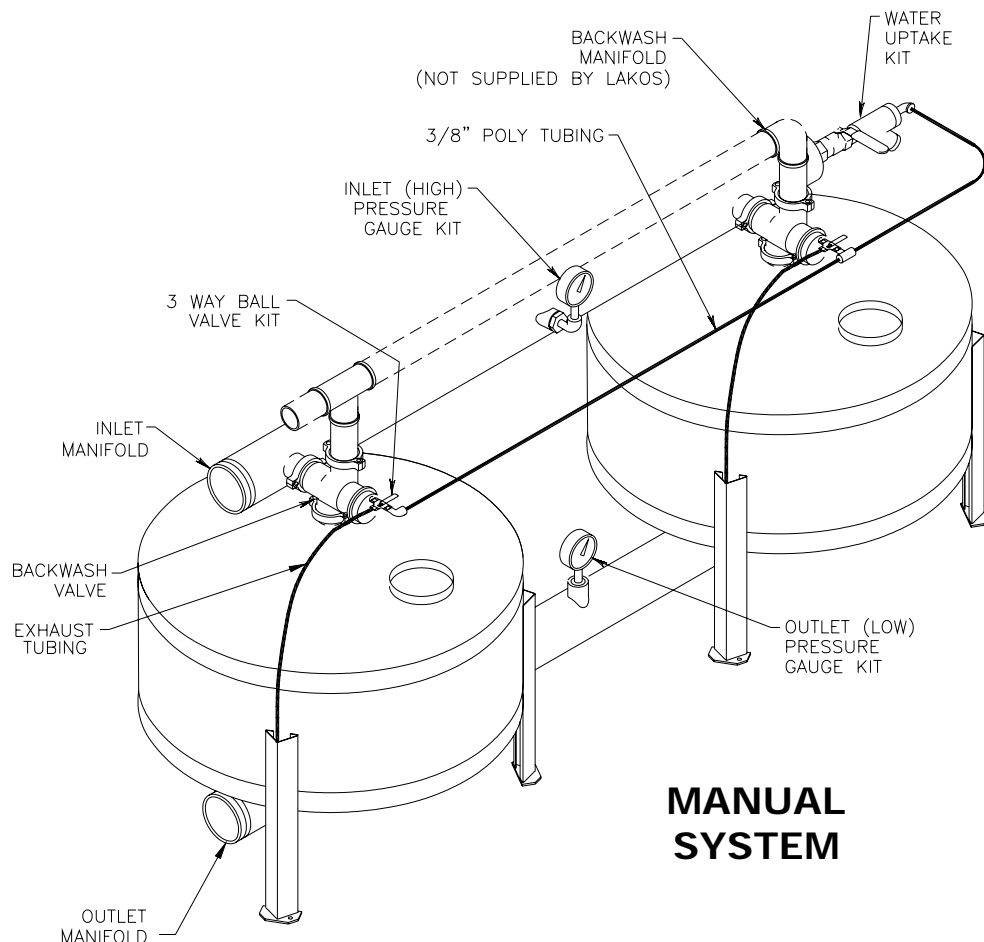

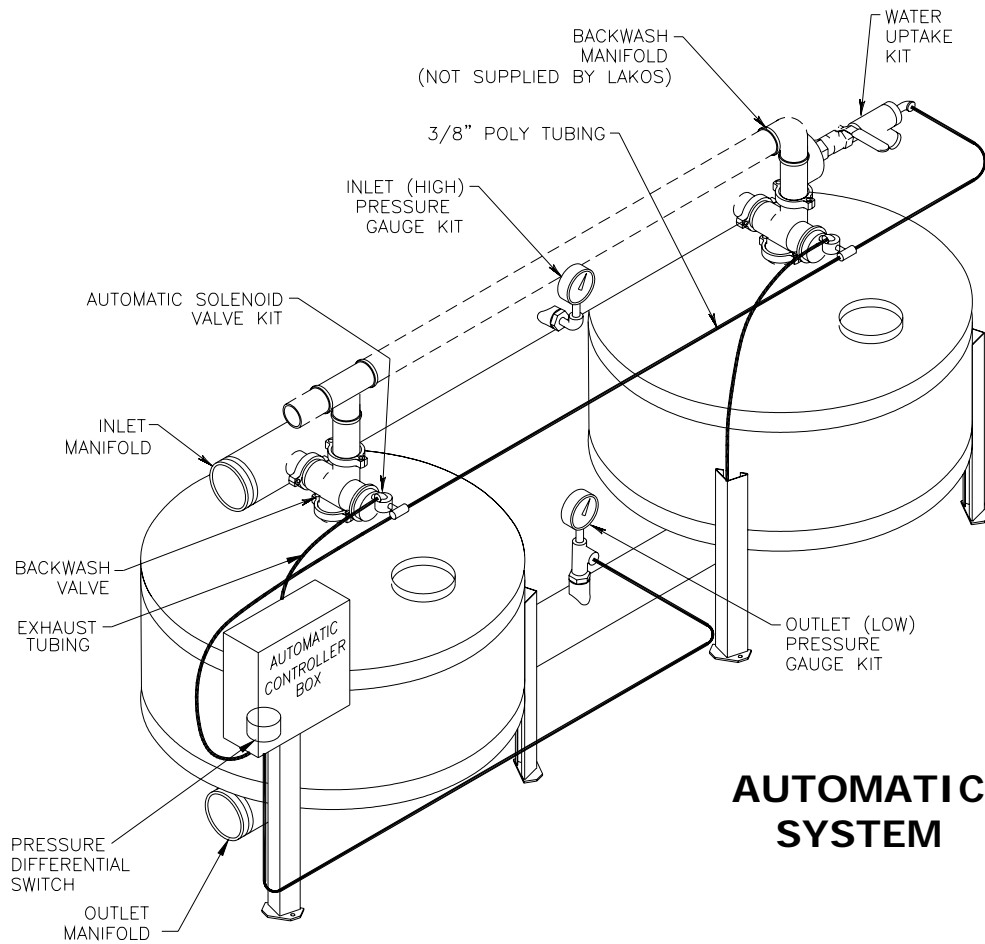

## Automatic Controller Configuration

For automatic systems only.

Follow all instructions included with the controller for proper installation and set-up. Note that the following settings must be verified before operating this controller. Each of these settings can be found on the backside of the inner control panel.

- **Output Voltage**

Select AC if 24 VAC solenoids are used on your backwash valves.

Select DC/DCL if your solenoids are either 12 VDC or 12 VDC Latching.

**IMPORTANT:** Do not mix the type of solenoids in your system. All solenoids must be the same type (24VAC, 12VDC or 12VDC Latching).

- **Number of Filters**

Properly switch ON the number of tanks in your system.

- **LATCH**

*If you are using 12 VDC Latching Solenoids*, locate the LATCH switch just below the filter tank selector switches. While controller is in idle, this switch must be moved to the right.

- **Backwash Counter**

Located on the upper left-hand corner of the panel is the reset switch to set the read-out to 000. Press button for one second to reset.

## Main Controller Panel Settings

The following functions on the main controller panel must also be set properly:

- **PERIODIC Flush Time**

This setting insures that the filter system will experience a backwash cycle as set, regardless of the pressure differential setting. In other words, if the contaminant build-up on the filter media does not cause a backwash cycle before this setting, the Periodic timer will initiate a full backwash cycle of all tanks. This prevents troublesome debris, such as fine silt or caking algae, from becoming too difficult to remove via normal backwashing. The recommended Periodic setting is 24 hours; set for more frequent intervals for more problematic contaminants.

- **FLUSH Duration**

Set the desired duration of your backwash cycle per tank. Typical setting is 90-120 seconds, but longer duration is recommended if the backwash flow does not run clear for about 10-15 seconds at the end of each tank's backwash cycle.

- **DWELL Time**

Each backwash valve needs time to open and close. Dwell time provides time for one backwash valve to close and the system to normalize before the next backwash valve opens in the backwash cycle. This setting is dependent on system pressure and the age of the backwash valve, but a range of 10 to 25 seconds is recommended.

- **Pressure Differential Switch**

The Automatic Controller includes a Pressure Differential Switch that must be set for proper operation. This device measures the line pressure difference between the inlet and outlet manifolds on your media filter system. When the pre-set pressure differential is reached, the PD switch will automatically initiate a full backwash cycle of all filter tanks, one tank at a time. Access this switch by opening the inner panel of the controller. Your LAKOS Filter System operates effectively with a pressure differential setting of 6-7 psi. Other settings could result in excessive backwashing or inadequate backwashing, either wasting water or clogging your media sand with too much contaminant material. NOTE: When pressure differential triggers a backwash sequence, the Periodic Flush Time (see above) is reset.

## Start-Up Procedures

- 1 Start the system pump or open the system valve that supplies water through the filter system. Allow time for water to fill the filter tanks and air to bleed out of the system. A minimum of 20 psi is required for system pressure in order to actuate backwash valves.
- 2 Media sand will require at least one initial backwash cycle (or more) before actual operation. Initiate the manual backwash of each filter tank, *one tank at a time*. To do so, turn the manual button on the automatic solenoid (or move the manual 3-way valve on the back of the backwash valve). Give the valve about 10-15 seconds to fully activate. The throttling valve on the backwash manifold (see Recommended Accessories, page 2) should be fully open at this time.
- 3 Once the flow through the backwash manifold becomes constant, the backwash water should be fairly dirty in appearance; this is especially true when starting-up a new system or new media sand has been added. At this time, slowly close the throttling valve to reduce backwash flow until only a trace of media sand is present in the backwash flow (about a small handful of media sand in the palm of your hand during a 2-minute backwash cycle is about right). Set the throttling valve to this position. Allow about two minutes for this initial backwash cycle. Manually adjust the solenoid (or move the 3-way valve for manual systems) to stop the backwash cycle for that filter tank.

**NOTE:** The manual adjustment for each solenoid should be OFF for normal operation. ON is the manual override.

- 4 Initiate a backwash cycle for each of the remaining filter tanks in the filter system, as noted above. No need to adjust the throttling valve again. If backwash water is not running fairly clear after this initial backwashing, repeat the backwashing cycle for all filter tanks. It is not unusual to run through three or more backwash cycles to initially clean new media sand.
- 5 During this initial operation and backwashing cycling, inspect the filter system and connections for any leaks. Adjust the throttling valve only if system flow or pressure changes. If inadequate backwash flow is observed, it may be necessary to install a valve on the system flow line downstream of the filter system to help divert the necessary flow to the backwash cycle. For an automatic system, this downstream valve will need to be adjusted electronically to coincide with each backwash cycle.

## Periodic/Mid-Season Maintenance

During an operating season, inspection should be performed regularly. How often you inspect and maintain your filter system can determine how long your filter system will last.

- 1 Shut off the system pump and disconnect power to the automatic controller. Open the upper inspection ports of each filter tank and inspect media sand for quantity and quality. Loss of sand suggests excessive backwashing. The presence of contaminants or slime suggests inadequate backwashing. Refer to Start-up Procedures on page 9 for backwash adjustments.
- 2 Via the automatic controller, initiate a manual backwash cycle by pressing the manual button for one second. Each filter tank should backwash as programmed. Note the dwell time and backwash duration.
- 3 Inspect all tubing & componentry for proper connections and any damage.
- 4 Check the y-strainer on the water uptake kit; clean internal screen if necessary.
- 5 Check the pressure gauges for expected readings.

## Seasonal Shutdown Procedures

LAKOS recommends that all SST tanks be shut down when not in active use for long periods of time. To do this:

- 1 Perform a long and somewhat aggressive backwash cycle for all filter tanks in the system, backwashing each tank for at least two minutes and opening the backwash throttling valve a bit more than normal operation.  
**CAUTION:** If any chemicals are introduced to the irrigation system at shutdown, it should be downstream of the filter system. If upstream, flush clean water through the filter system before shutting down the filter system at season's end.
- 2 Shut down the system pump and disconnect power to the automatic controller (if applicable). Open each tank and inspect for sand quantity and quality. If additional or new sand is needed, make note to add the necessary sand prior to start-up before next season.  
**CAUTION:** The presence of slime anywhere inside the tanks or excessive contaminants throughout the sand media suggests the need to replace all media sand. Remove all sand from the media tanks at this time, but do not introduce new sand until just prior to start-up for next season.

- 3 Drain the filter system completely of all water. It is best to open a coupling connection on outlet manifold of the filter system to ensure that all water is drained from the lowest point of the filter system.
- 4 All systems: Clean the y-strainer on the water uptake kit.
5. For optimum life expectancy, lubricate the internal shaft of each LAKOS Backwash Valve. Remove the solenoid (automatic systems only) or manual 3-way valve (manual systems only) from the back connection of the backwash valve body. Remove the system backwash line to gain access to the backwash outlet of the valves. Inject air into the back port of each backwash valve (about 20-25 psi) in order to push the internal shaft of the backwash valve into the backwashing position. This exposes the internal shaft to access via the backwash outlet. Maintain this position and apply lubricant onto the shaft. Release the air pressure and allow the lubricated shaft to recede into the body of the backwash valve, lubricating the internal o-rings. Re-attach the solenoids or 3-way valves and backwash line.

## **Backwash Valve Repair Recommendations**

### **REMOVE THE BACKWASH VALVE FROM THE SYSTEM**

1. Begin by removing the back cover from the valve. This will eliminate the need to remove the solenoid, conduit & wiring.
2. Inspect the rubber diaphragm covering the piston. The “smooth and shiny” side of this diaphragm should be facing the back cover of the valve; the cloth-like rough surface should be wrapped around the piston. Check for tears, wear or any holes in this part. Replace if necessary.
3. Loosen and remove the three grooved couplings to release the valve body from the tank and inlet/backwash manifolds.

### **INSPECT / REPLACE THE DISC**

1. Locate (from the backwash opening of the valve body) the 7/16-inch machined portion of the backwash valve’s shaft. Secure that shaft with a wrench to prevent it from rotating.
2. Using the appropriate ratchet with extension, enter the valve body from the inlet opening and loosen the end nut. Disc is removed via the valve’s outlet (to the filter tank).
3. Inspect the rubber on the disc. If it is worn, torn or deformed, it should be replaced.

### **REMOVE THE SHAFT**

This procedure will likely damage the diaphragm. Be prepared to replace the diaphragm.

1. Grasp the piston and pull it straight out of the back of the valve body. The shaft will follow.
2. Inspect the piston for damage of the epoxy coating. If any nicks or scratches are noted, replace the piston.
3. To remove the shaft from the piston, first secure the center section of the shaft (where machined) with a 7/16-inch wrench to prevent rotation. Using a 5/32-inch allen wrench, loosen and remove the pan-head screw located on the face of the piston.
4. Remove the spring. The spring should have a tension of approximately 60 to 70 foot-pounds of pressure. Normal life expectancy is 5 to 7 years. Replacement during maintenance may be more cost-effective than trying to overextend the life of this part.
5. Remove the two o-rings on the shaft (these should be replaced whenever servicing the valve) and inspect the shaft for any rough surfaces. Replace if evident.
6. Wipe all re-usable parts with a clean cloth.

## RE-ASSEMBLING THE SHAFT

1. Be sure that the shaft is clean and free of any debris in the groove. Carefully slide the o-ring onto the shaft and into the groove. Apply a small amount of petroleum jelly to lubricate the o-ring.
2. Clean the inside of the stainless steel bushing.
3. Attach the shaft to the piston, using an allen wrench.
4. Place the spring over the shaft, allowing it to rest on the inside of the piston.
5. Guide the threaded end of the shaft through the bushing, using extra care when the o-ring enters the bushing.
6. Test the movement of the shaft in the bushing. It should glide smoothly, not allowing the o-ring to slip out of its groove. If the o-ring does move, apply more petroleum jelly to the o-ring and shaft.

## RE-ATTACHING THE DISC

1. *L-0801-A Valve*: Position the stainless steel insert on the bevelled side of the disc against the flat surface inside the inlet of the valve body.
2. *L-0801-B Valve*: Position the stainless steel insert and rubber guard plate against the flat surface inside the inlet of the valve body.
3. Slide the shaft assembly from the backside of the valve body, through the backwash outlet chamber and toward the backwash valve's inlet. Attach the shaft to the disc, securing the shaft with a 7/16-inch wrench and tightening the lock nut onto the disc.
4. Apply pressure to the piston and again check the shaft for smooth travel through the bushing.

## RE-ATTACHING THE DIAPHRAGM

1. The diaphragm is marked to identify the "pressure side", which should be the side facing the rear of the valve (exposed to the solenoid). Avoid wrinkling or pinching the diaphragm between the piston and the valve body.
2. At this point, re-install the backwash valve onto the filter tank and manifolds, using the grooved-end couplings.
3. Align the holes on the lip of the diaphragm with the holes on the backwash valve body.
4. Place the backwash valve's back cover into position, being careful to keep the lip of the diaphragm flat against the valve body (creating a gasket between the valve body and back cover). The solenoid should be in the top (12 o'clock) position.
5. Insert the bolts, slide on the lock-washers and secure the nuts to firmly re-attach the back cover to the backwash valve.

# Troubleshooting

PROBLEM	POSSIBLE CAUSES	SOLUTIONS
Poor Filtration	<ul style="list-style-type: none"> <li>● Excessive flow through filters, causing “coning” of media sand and/or forcing contaminants through filter outlet.</li> <li>● Air in tank(s) may cause disruption of the media sand bed.</li> <li>● Incorrect media sand.</li> <li>● Excessively high pressure differential before backwashing, which forces contaminants through filter bed.</li> <li>● Insufficient volume of media in filter, which allows contaminants to pass through the system.</li> </ul>	<ol style="list-style-type: none"> <li>1. Reduce flow rate or add extra filter tank(s). See page 5 for flow recommendations.</li> <li>2. Bleed off trapped air in system.</li> <li>3. Replace with proper media sand. Consult your LAKOS representative.</li> <li>4. Backwash more often at lower differential pressure.</li> <li>5. Add proper sand media to tank(s) to specified level.</li> </ol>
Consistently High Pressure Differential	<ul style="list-style-type: none"> <li>● Excessive contaminant load restricts flow through the filters and prevents sufficient flow for backwashing.</li> <li>● Insufficient backwash flow.</li> <li>● Inadequate media sand volume, which may minimize coverage of backwash flow across filter bed, creating dead spots of accumulated contaminants.</li> </ul>	<ol style="list-style-type: none"> <li>1. Drain tank(s) and remove hand-hole access ports. Carefully skim away any excess or caked contaminants from the media sand bed’s surface. Return tank(s) to normal service and backwash system.</li> <li>2. Readjust backwash or partially close field valve.</li> <li>3. Follow #1 and add sand media as necessary.</li> </ol>
Increasing Frequency of Backwash Cycle	<ul style="list-style-type: none"> <li>● Backwash flow or duration is not adequate to flush filter tanks of all contaminants.</li> <li>● Insufficient sand volume.</li> <li>● Increased concentration of contaminants in water supply.</li> </ul>	<ol style="list-style-type: none"> <li>1. Adjust backwash flow or duration.</li> <li>2. Add media sand to achieve proper volume.</li> <li>3. Adjust backwash frequency or reduce pressure differential setting to achieve more frequent backwash cycles.</li> </ol>
Automatic Backwash Fails to Cycle	<ul style="list-style-type: none"> <li>● Controller power may be off or circuit breaker tripped.</li> <li>● Improper setting of differential switch.</li> <li>● Solenoid(s) malfunctioning.</li> <li>● Loss of sufficient pressure to actuate valve(s).</li> </ul>	<ol style="list-style-type: none"> <li>1. Be sure wiring is connected correctly. Reset circuit breaker. Turn on power. Controller may be faulty and need replacement.</li> <li>2. Adjust as necessary. Typical is 6-7 psi.</li> <li>3. Check connections, clean ports and check for the sound of the solenoid actuating. Replace solenoid if necessary.</li> <li>4. Check filter screen on water uptake kit and hydraulic lines for clogs or breaks/leaks. Replace as necessary.</li> </ol>

# Troubleshooting

PROBLEM	POSSIBLE CAUSES	SOLUTIONS
Media Sand Appears Down-stream	<ul style="list-style-type: none"> <li>● Incorrect media sand (i.e. too fine and too small)</li> <li>● Broken, damaged, or missing lateral.</li> </ul>	<ol style="list-style-type: none"> <li>1. Replace media with proper sized media.</li> <li>2. Repair or replace laterals of the underdrain.</li> </ol>
Backwash Valve Leaks	<ul style="list-style-type: none"> <li>● Obstruction in the valve seat.</li> <li>● Rubber seating disc is worn or damaged.</li> <li>● Diaphragm damaged (Leaking from bleed port hole located on the piston chamber).</li> </ul>	<ol style="list-style-type: none"> <li>1. Remove the obstruction.</li> <li>2. Replace seat disc.</li> <li>3. Replace diaphragm.</li> </ol>
Water Hammer	<ul style="list-style-type: none"> <li>● Air in tanks.</li> <li>● Long backwash line causing vacuum.</li> </ul>	<ol style="list-style-type: none"> <li>1. Bleed off trapped air in system. Air vent on system may be required.</li> <li>2. Install vacuum breaker on backwash line.</li> </ol>



# APPENDIX

## Kits and Spare Parts Listing

On the stapled set LS-695  
for SST Sand Media Kits

### **CLAUDE LAVAL CORPORATION**

1365 North Clovis Avenue  
Fresno, California 93727 USA  
Telephone: (559) 255-1601 Fax: (559) 255-8093  
Toll-free: (800) 344-7205 (USA, Canada & Mexico)  
Email: [info@lakos.com](mailto:info@lakos.com)

[www.LAKOS.com](http://www.LAKOS.com)

# **LAKOS**