

EXCEPT AS OTHERWISE PROVIDED BY CONTRACT, THIS DRAWING AND SPECIFICATIONS SHALL NOT BE REPRODUCED, COPIED OR USED AS THE BASIS FOR MANUFACTURE OR SALE OF MATTER DEPICTED HEREIN WITHOUT THE EXPRESSED WRITTEN PERMISSION OF THE CLAUDE LAVAL CORPORATION, OR ITS ASSIGNEES.

NOTES:

1. INLET & OUTLET ARE 20" GROOVED PIPE.
2. MAXIMUM PRESSURE: 150 psi (10.3 bar).
3. MAXIMUM TEMPERATURE: 180°F (82.2°C).
4. PRESSURE LOSS: 3-12 psid (.2-.8 bar) AT RATED FLOW.
5. RATED FLOW: 6700-12750 gpm (1520-2895 m³/hr).
6. APPROXIMATE DRY WEIGHT: 5744 lbs (2605 kg).
7. FINISH: LAKOS BLACK (EXTERIOR ONLY).

REVISION HISTORY				
ZONE	REV	DESCRIPTION	DATE	APPROVED

THIS DRAWING HAS BEEN GENERATED AND IS MAINTAINED BY A CAD SYSTEM. CHANGES SHALL ONLY BE INCORPORATED AS DIRECTED BY AN APPROVED ENGINEERING CHANGE ORDER (ECO). PAPER COPIES ARE UNCONTROLLED.

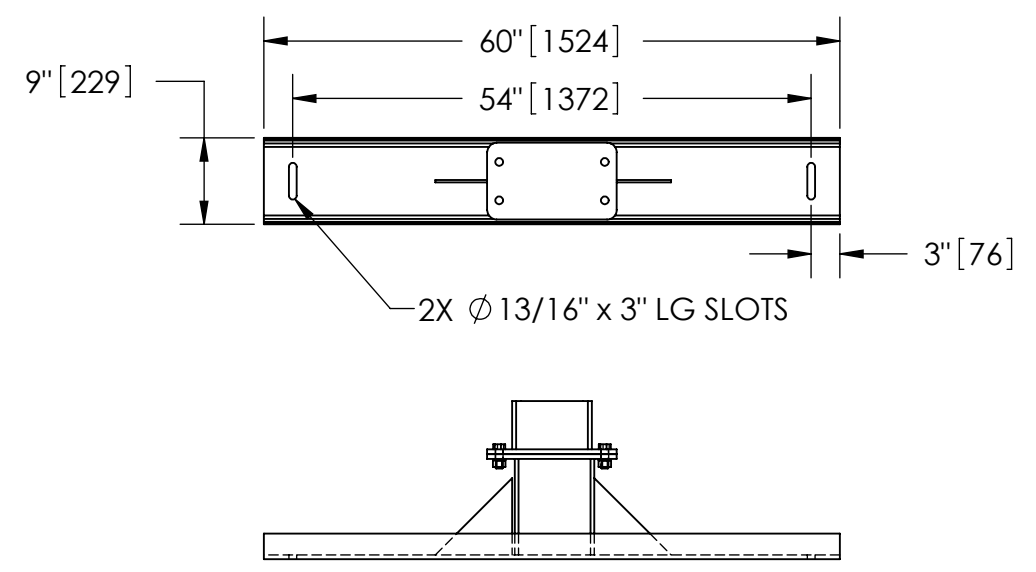

SECTION B-B

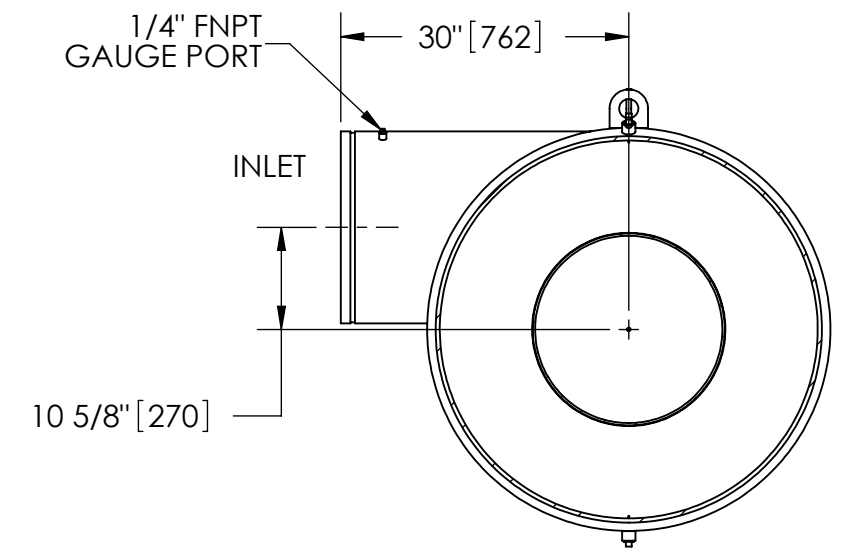

SECTION A-A

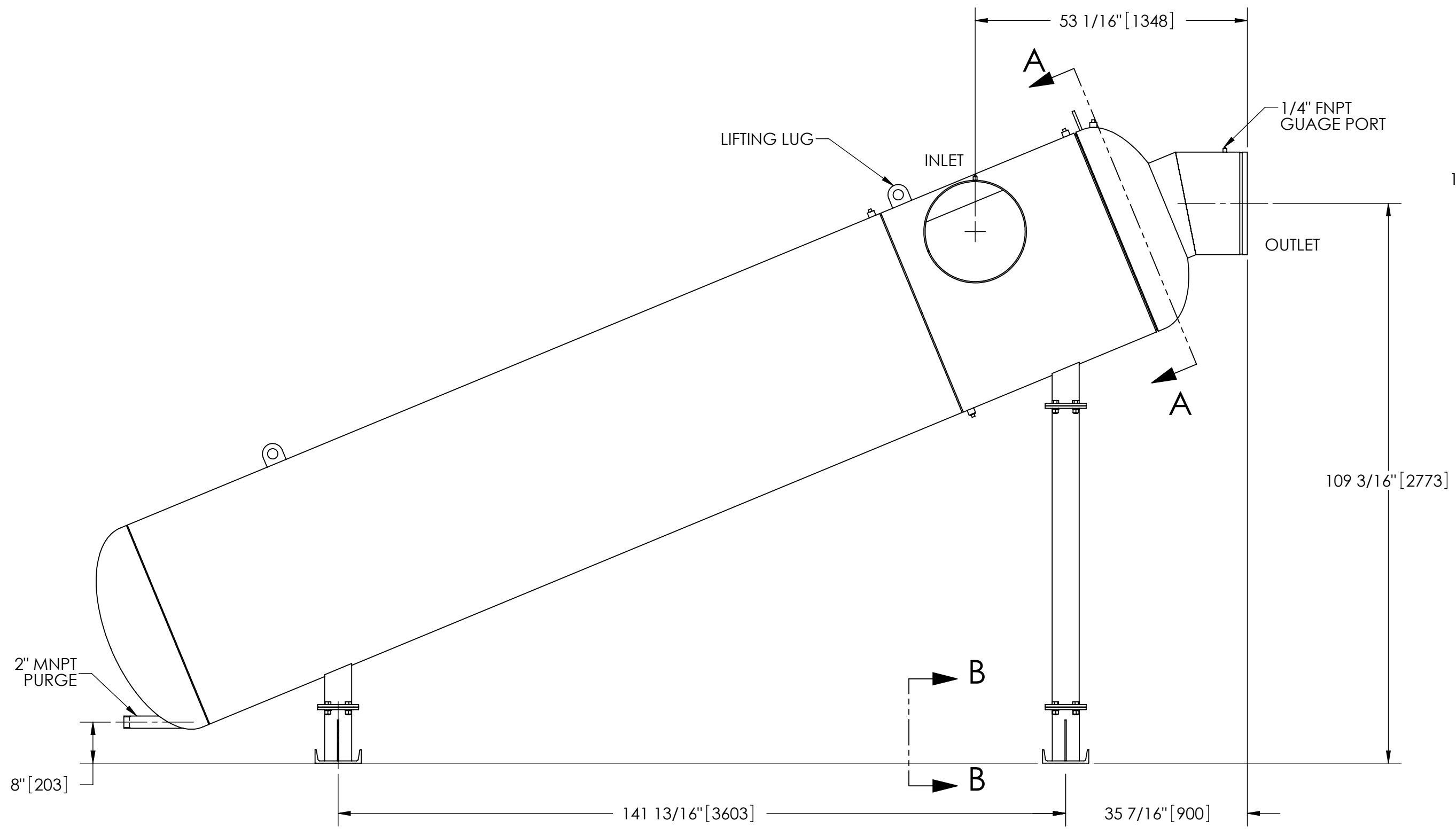

SUBMITTAL DRAWING

This drawing is submitted for spatial consideration only. Do not pre-plumb to these dimensions.

UNLESS OTHERWISE SPECIFIED: DIMENSIONS ARE IN: INCHES [mm] TOLERANCES ARE: FRACTIONS DECIMALS ANGLES ± 1/4" .XX ± .01 ± 1/4° .XXX ± .005 .XXXX ± .0005		ENGINEERED FOR: STANDARD		CLAUDE LAVAL CORP. FRESNO, CALIFORNIA 93727 WWW.LAKOS.COM		LAVAL UNDERGROUND SURVEYS	
DO NOT SCALE DRAWING		APPROVALS	DATE	TITLE			
MATERIAL: CLASS P-1 MILD CARBON STEEL		DRAWN: DLW	1/26/06	HTH-6700-L, SEPARATOR, 6700-12750 gpm, CARBON STEEL			
FINISH: LAKOS BLACK		ENGR: β	1/30/06	SIZE: C	MODEL NO.	DWG NO. 115305	REV. B
		WORK ORDER	QTY.	SCALE: 1:20	EST. WT. 5744 lb	SHEET 1 OF 1	

DWG. NO. 115305 SH 1 REV. B