

EXCEPT AS OTHERWISE PROVIDED BY CONTRACT, THIS DRAWING AND SPECIFICATIONS SHALL NOT BE REPRODUCED, COPIED OR USED AS THE BASIS FOR MANUFACTURE OR SALE OF MATTER DEPICTED HEREIN WITHOUT THE EXPRESSED WRITTEN PERMISSION OF THE CLAUDE LAVAL CORPORATION, OR ITS ASSIGNEES.

NOTES:

1. INLET & OUTLET ARE 16" (406 mm) GROOVED PIPE.
2. MAXIMUM PRESSURE: 150 psi (10.3 bar).
3. MAXIMUM TEMPERATURE: 180°F (82.2°C).
4. PRESSURE LOSS: 3-12 psid (.2-.8 bar) AT RATED FLOW.
5. RATED FLOW: 3500-6800 gpm (795-1545 m<sup>3</sup>/hr).
6. APPROXIMATE DRY WEIGHT: 2946 lbs (1336 kg).
7. FINISH: LAKOS BLACK (EXTERIOR ONLY).

REVISION HISTORY				
ZONE	REV	DESCRIPTION	DATE	APPROVED

THIS DRAWING HAS BEEN GENERATED AND IS MAINTAINED BY A CAD SYSTEM. CHANGES SHALL ONLY BE INCORPORATED AS DIRECTED BY AN APPROVED ENGINEERING CHANGE ORDER (ECO). PAPER COPIES ARE UNCONTROLLED.

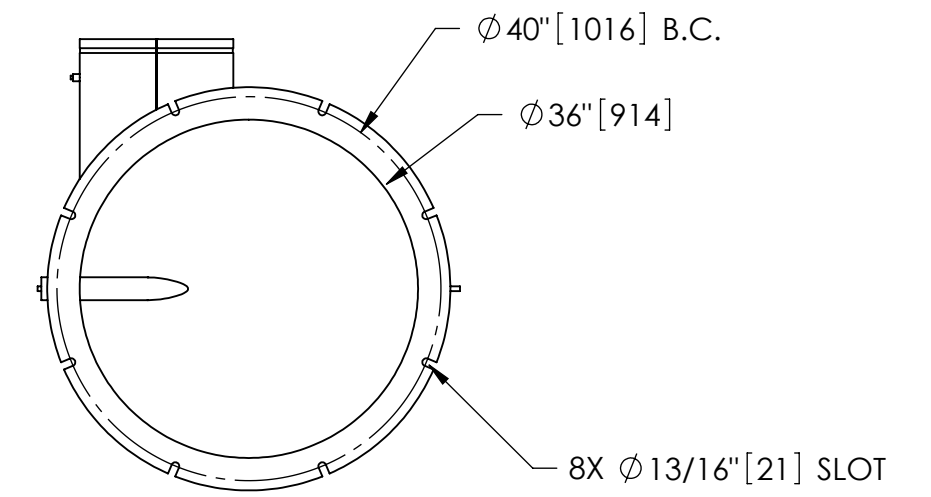
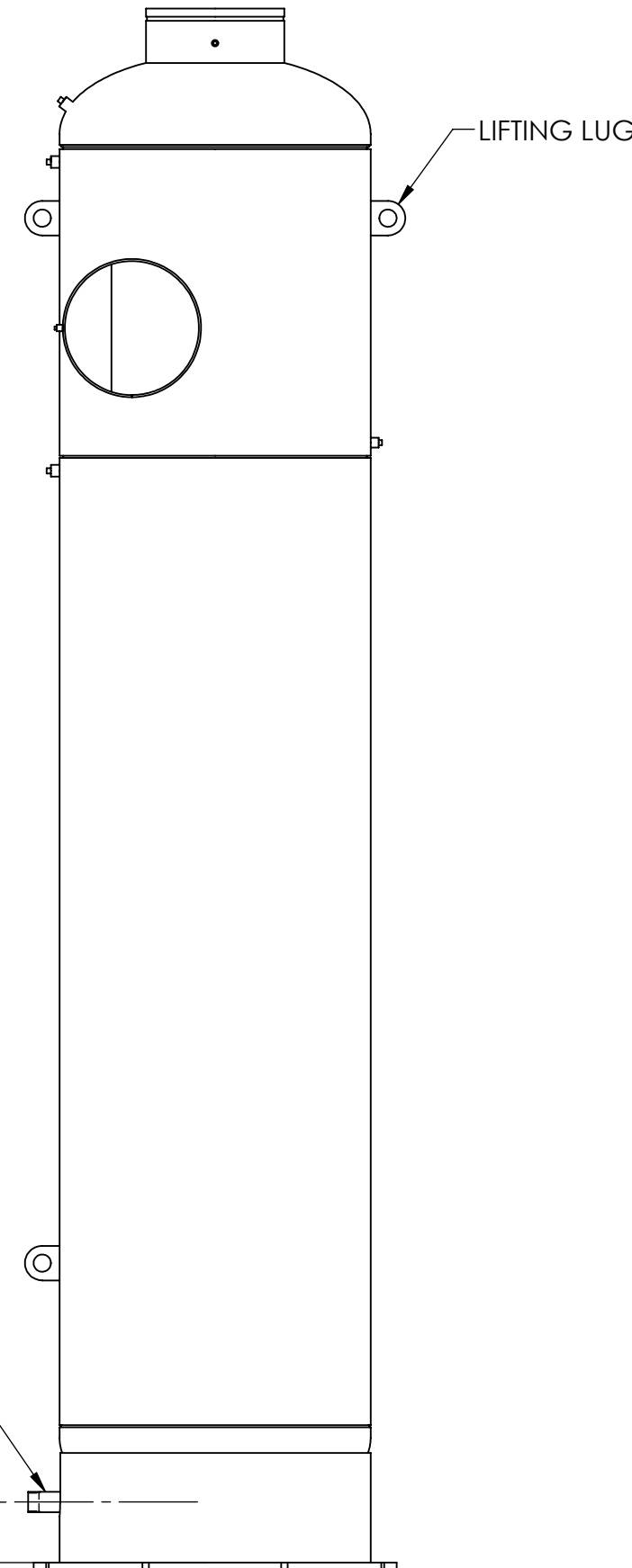
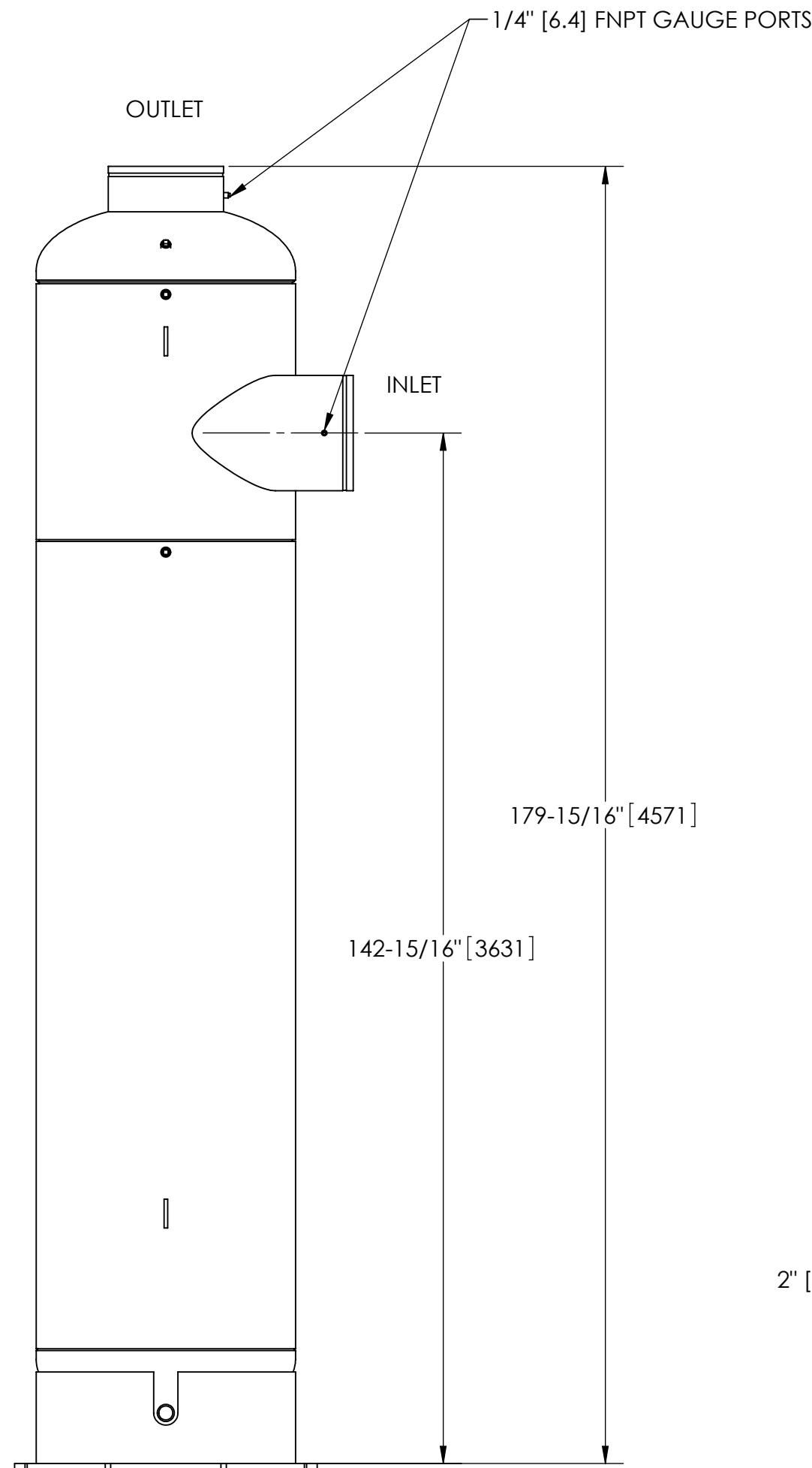
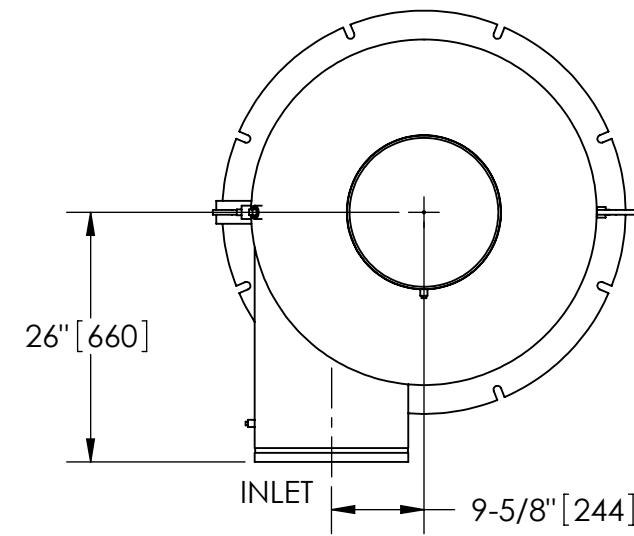

**BOTTOM VIEW**

**SUBMITTAL DRAWING**

This drawing is submitted for spatial consideration only. Do not pre-plumb to these dimensions.

UNLESS OTHERWISE SPECIFIED: DIMENSIONS ARE IN: INCHES (mm) TOLERANCES ARE: FRACTIONS    DECIMALS    ANGLES ± 1/4"    .XX ± .01    ± 1/4° .XXX ± .005 .XXXX ± .0005		ENGINEERED FOR: <b>STANDARD</b>		CLAUDE LAVAL CORP. FRESNO, CALIFORNIA 93727 WWW.LAKOS.COM		LAVAL UNDERGROUND SURVEYS	
DO NOT SCALE DRAWING		APPROVALS	DATE	TITLE			
MATERIAL CLASS P-1 MILD CARBON STEEL		DRAWN DLW	1/27/06	HTH-3500-V, SEPARATOR, 3500-6800 gpm, CARBON STEEL			
FINISH LAKOS BLACK		ENGR β	1/30/06	SIZE C	MODEL NO.	DWG NO. 115304	REV. E
		WORK ORDER	QTY.	SCALE 1:20	EST. WT. 2946 lb	SHEET 1 OF 1	

DWG NO. 115304 SH 1 REV. E