

EXCEPT AS OTHERWISE PROVIDED BY CONTRACT, THIS DRAWING AND SPECIFICATIONS SHALL NOT BE REPRODUCED, COPIED OR USED AS THE BASIS FOR MANUFACTURE OR SALE OF MATTER DEPICTED HEREIN WITHOUT THE EXPRESSED WRITTEN PERMISSION OF THE CLAUDE LAVAL CORPORATION, OR ITS ASSIGNEES.

NOTES:

1. INLET & OUTLET ARE 8" GROOVED PIPE.
2. MAXIMUM PRESSURE: 150 psi (10.3 bar).
3. MAXIMUM TEMPERATURE: 180°F (82.2°C).
4. PRESSURE LOSS: 3-12 psid (.2-.8 bar) AT RATED FLOW.
5. RATED FLOW: 1160-2150 gpm (265-490 m<sup>3</sup>/hr).
6. APPROXIMATE DRY WEIGHT: 1309 lbs (595 kg).
7. FINISH: LAKOS BLUE (EXTERIOR ONLY).

REVISION HISTORY				
ZONE	REV	DESCRIPTION	DATE	APPROVED

THIS DRAWING HAS BEEN GENERATED AND IS MAINTAINED BY A CAD SYSTEM. CHANGES SHALL ONLY BE INCORPORATED AS DIRECTED BY AN APPROVED ENGINEERING CHANGE ORDER (ECO). PAPER COPIES ARE UNCONTROLLED.

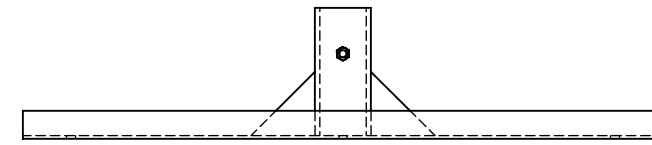
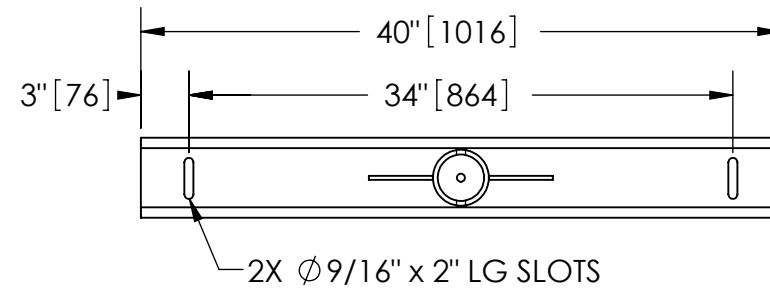

SECTION B-B

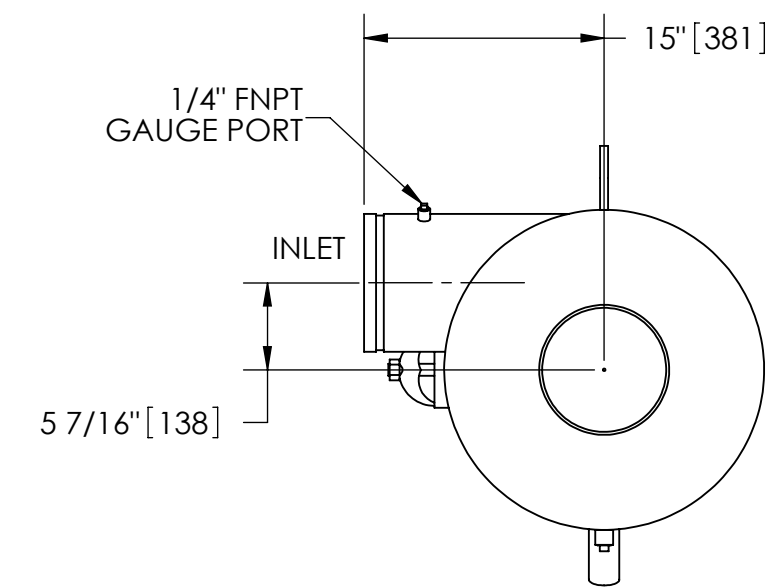

SECTION A-A

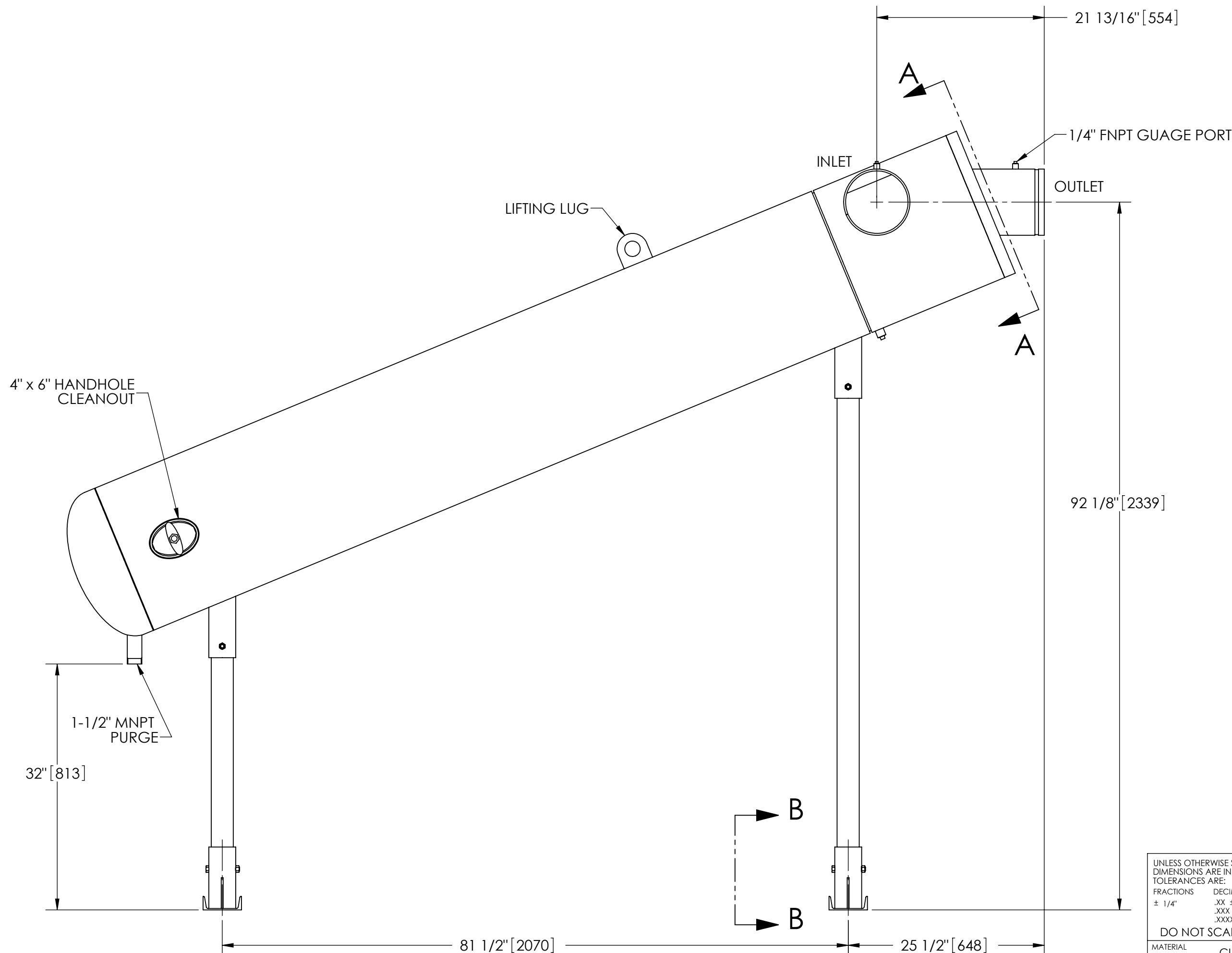

**SUBMITTAL DRAWING**

This drawing is submitted for spatial consideration only. Do not pre-plumb to these dimensions.

UNLESS OTHERWISE SPECIFIED: DIMENSIONS ARE IN: INCHES [mm] TOLERANCES ARE: FRACTIONS DECIMALS ANGLES ± 1/4" .XX ± .01 ± 1/4" XXX ± .005 XXXX ± .0005		ENGINEERED FOR: <b>STANDARD</b>		CLAUDE LAVAL CORP. FRESNO, CALIFORNIA 93727 WWW.LAKOS.COM	
DO NOT SCALE DRAWING		APPROVALS	DATE	TITLE	
MATERIAL	CLASS P-1 MILD CARBON STEEL	DRAWN	DLW	1/16/06	<b>JPL-1160-L, SEPARATOR, 1160-2150 gpm, CARBON STEEL</b>
FINISH	LAKOS BLUE	ENGR	b	2/3/06	
SCALE		WORK ORDER	QTY.	SIZE	MODEL NO.
1:12				C	
EST. WT.		DWG NO.		REV.	
1319 lb		115263		E	
SHEET		1 OF 1			

DWG NO.

115263

SHT

1

REV.

E

A