

EXCEPT AS OTHERWISE PROVIDED BY CONTRACT, THIS DRAWING AND SPECIFICATIONS SHALL NOT BE REPRODUCED, COPIED OR USED AS THE BASIS FOR MANUFACTURE OR SALE OF MATTER DEPICTED HEREIN WITHOUT THE EXPRESSED WRITTEN PERMISSION OF THE CLAUDE LAVAL CORPORATION, OR ITS ASSIGNEES.

NOTES:

1. INLET & OUTLET ARE 8" GROOVED PIPE.
2. MAXIMUM PRESSURE: 150 psi (10.3 bar).
3. MAXIMUM TEMPERATURE: 180°F (82.2°C).
4. PRESSURE LOSS: 3-12 psid (.2-.8 bar) AT RATED FLOW.
5. RATED FLOW: 1160-2150 gpm (265-490 m³/hr).
6. APPROXIMATE DRY WEIGHT: 1301 lbs (590 kg).
7. FINISH: LAKOS BLUE (EXTERIOR ONLY).

REVISION HISTORY				
ZONE	REV	DESCRIPTION	DATE	APPROVED

THIS DRAWING HAS BEEN GENERATED AND IS MAINTAINED BY A CAD SYSTEM. CHANGES SHALL ONLY BE INCORPORATED AS DIRECTED BY AN APPROVED ENGINEERING CHANGE ORDER (ECO). PAPER COPIES ARE UNCONTROLLED.

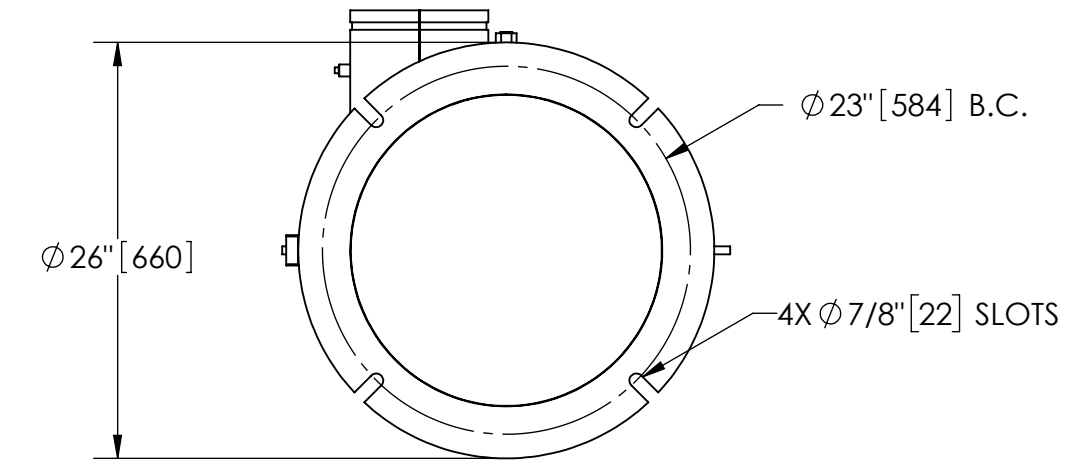
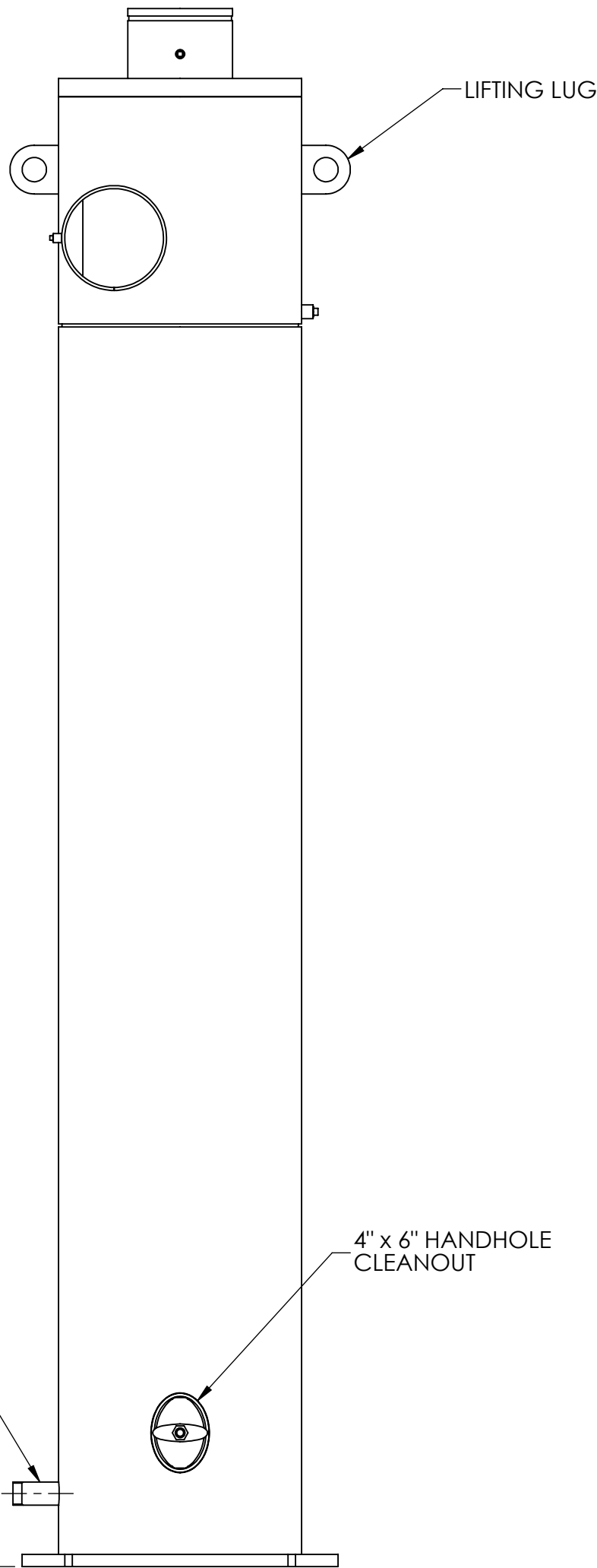
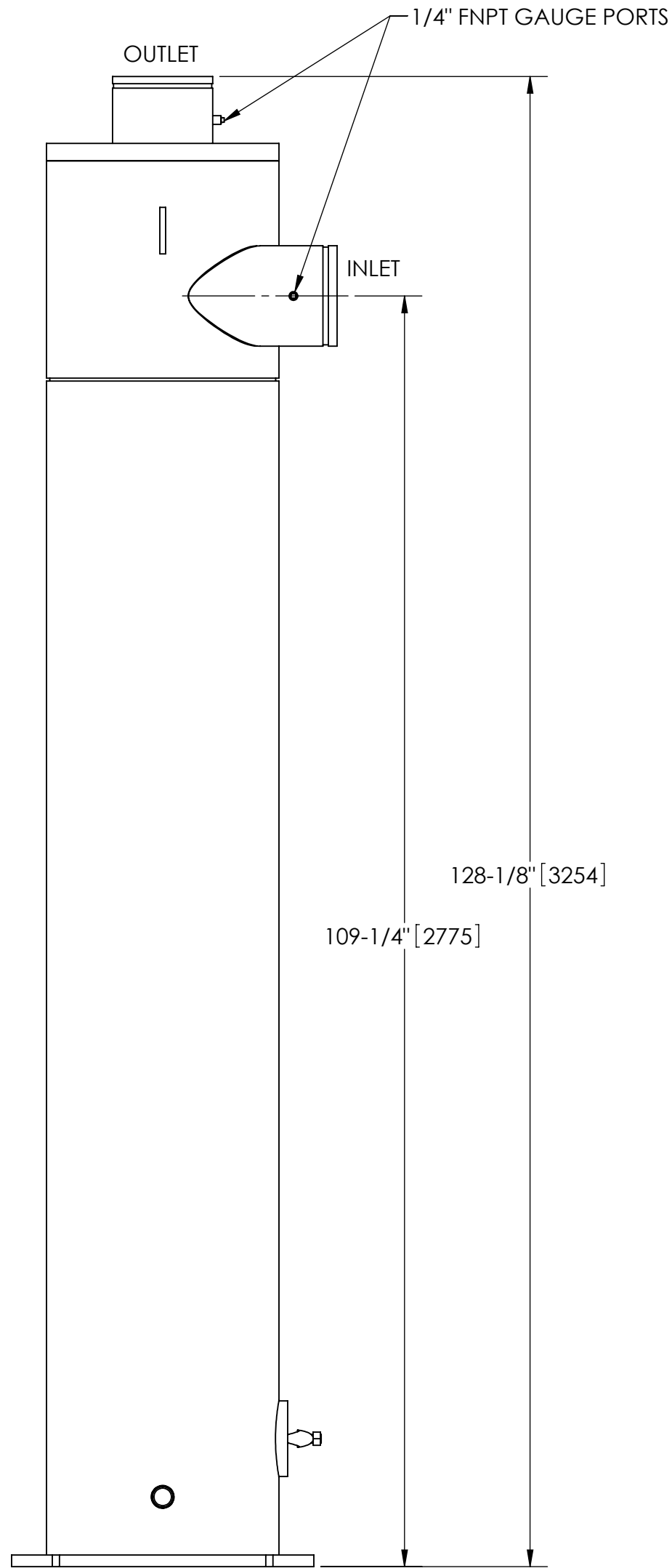
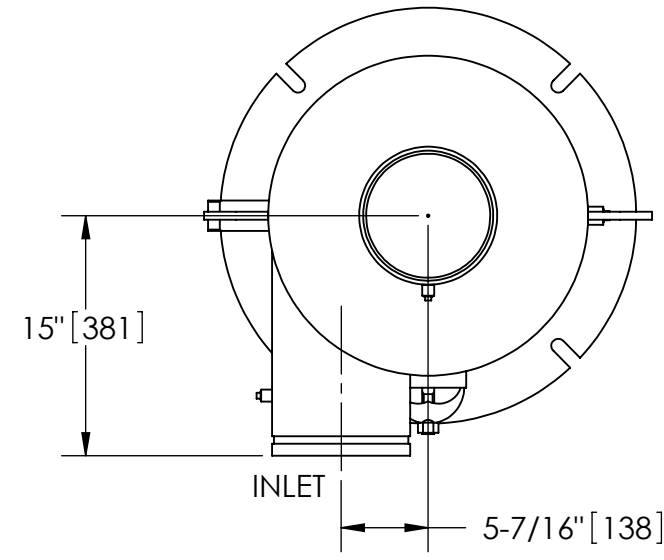

BOTTOM VIEW

SUBMITTAL DRAWING

This drawing is submitted for spatial consideration only. Do not pre-plumb to these dimensions.

UNLESS OTHERWISE SPECIFIED: DIMENSIONS ARE IN: INCHES (mm) TOLERANCES ARE: FRACTIONS DECIMALS ANGLES ± 1/4" .XX ± .01 ± 1/4° XXX ± .005 XXXX ± .0005		ENGINEERED FOR: STANDARD		LAKOS CLAUDE LAVAL CORP. FRESNO, CALIFORNIA 93727 WWW.LAKOS.COM	
DO NOT SCALE DRAWING		APPROVALS	DATE	TITLE	
MATERIAL CLASS P-1 MILD CARBON STEEL		DRAWN DLW	1/27/06	JPL-1160-V, SEPARATOR, 1160-2150 gpm, CARBON STEEL	
FINISH LAKOS BLUE		ENGR b	2/3/06	SIZE C	MODEL NO.
		MFG -	-	DWG NO. 115264	REV. E
		WORK ORDER	QTY.	SCALE 1:12	EST. WT. 1301 lb SHEET 1 OF 1

DWG NO.

115264

SHT 1

REV. E

A