

4

2

1

EXCEPT AS OTHERWISE PROVIDED BY CONTRACT, THIS DRAWING AND SPECIFICATIONS SHALL NOT BE REPRODUCED, COPIED OR USED AS THE BASIS FOR MANUFACTURE OR SALE OF MATTER DEPICTED HEREIN WITHOUT THE EXPRESSED WRITTEN PERMISSION OF THE LAKOS CORPORATION, OR ITS ASSIGNEES.

THIS DRAWING HAS BEEN GENERATED AND IS MAINTAINED BY A CAD SYSTEM. CHANGES SHALL ONLY BE INCORPORATED AS DIRECTED BY AN APPROVED ENGINEERING CHANGE ORDER (ECO). PAPER COPIES ARE UNCONTROLLED.

REVISION HISTORY				
ZONE	REV	DESCRIPTION	DATE	APPROVED
	A	RELEASED FOR SUBMITTAL	1/19/21	ADJ

NOTES:

- INLET IS 6" FLANGED (125# ANSI FLANGED).
- OUTLET IS 4" PIPE (GROOVED).
- PURGE OUTLET IS 1-1/2" PIPE.
- MAXIMUM PRESSURE: 150 psi (10.3 bar).
- MAXIMUM FLUID OPERATING TEMPERATURE: 100°F (37.8°C).
- MAXIMUM AIR OPERATING TEMPERATURE: 100°F (37.8°C).
- SPECIFIED FLOW RATES:
 BASIN SWEEPING - 410 gpm (93 m³/hr).
 SIDE STREAM & CLOSED LOOP- 450 gpm (114 m³/hr).
- FINISH: AS ASSEMBLED.
- POWER REQUIREMENT: 3/60/208 230 460V
- NEMA 4X MOTOR STARTER ENCLOSURE WITH SAFETY DISCONNECT AND H.O.A. SWITCH.
- APPROXIMATE DRY WEIGHT: 1557 lbs (706 kg).
- INLET/OUTLET VALVE KIT RECOMMENDED: SEE FACTORY.
- MINIMUM PIPE FROM TOWER TO TC SYSTEM IS 6" PIPE.
- FLOODED SUCTION REQUIRED.

System Part Numbers	Electrical Box	Power Requirements
184851-208V	184629	3/60/208V
184851-230V	184633	3/60/230V
184851-460V	129026	3/60/460V

COMPONENT LIST:

- ELECTRICAL CONTROL BOX 3/60/208 230 460V W/120V TRANSFORMER.
- SEPARATOR: eHTX-0140-V.
- PUMP: 10 HP CENTRIFUGAL, 1750 rpm, 3/60/208 230 460V.
- INLET/OUTLET PRESSURE GAUGES: 0-160 psi, GLYCERIN-FILLED.
- PURGE EQUIPMENT: EFS-15-120V.
- STRAINER SUCTION DIFFUSER.

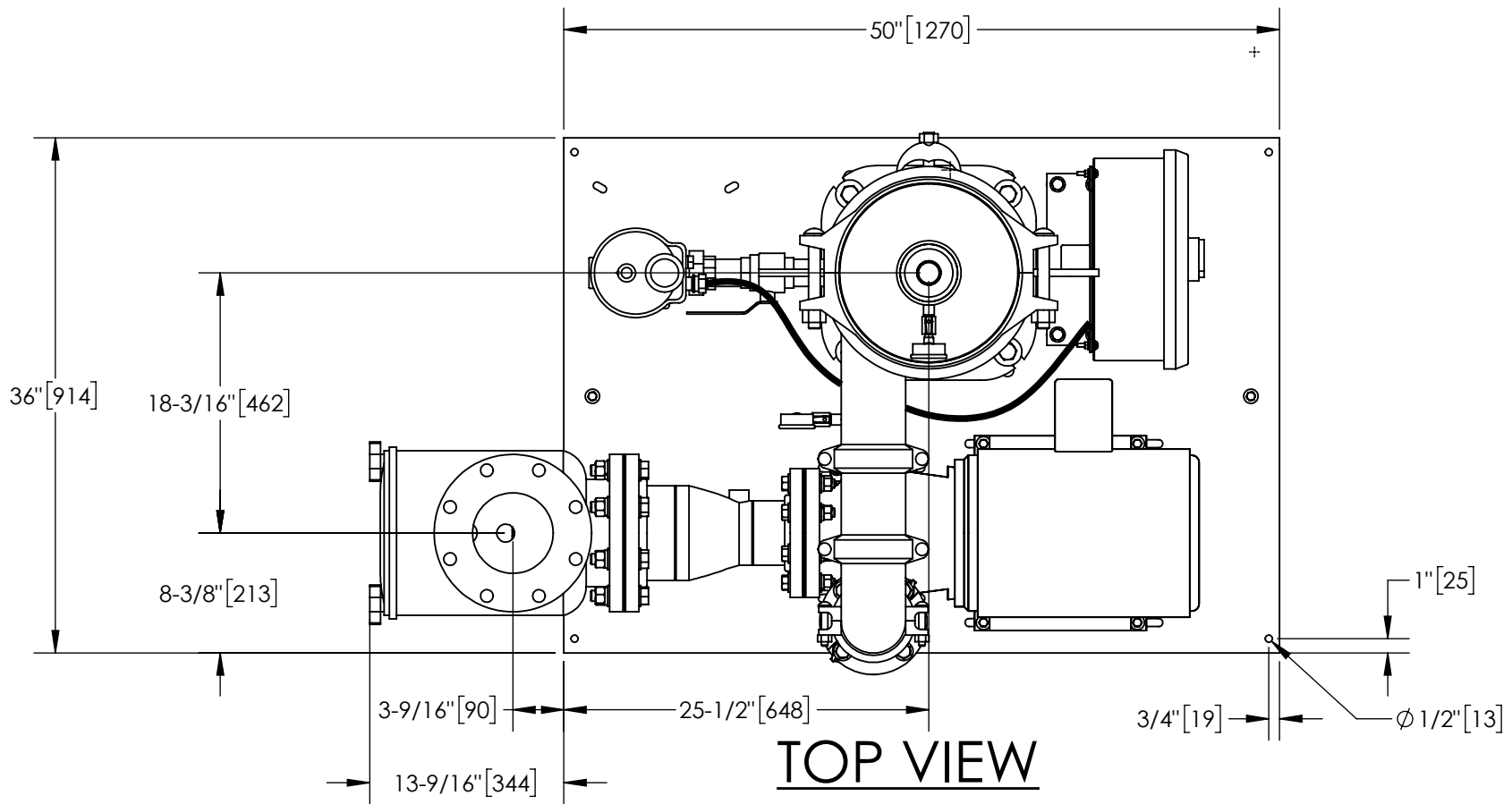

SUBMITTAL DRAWING

This drawing is submitted for spatial consideration only. Do not pre-plumb to these dimensions.

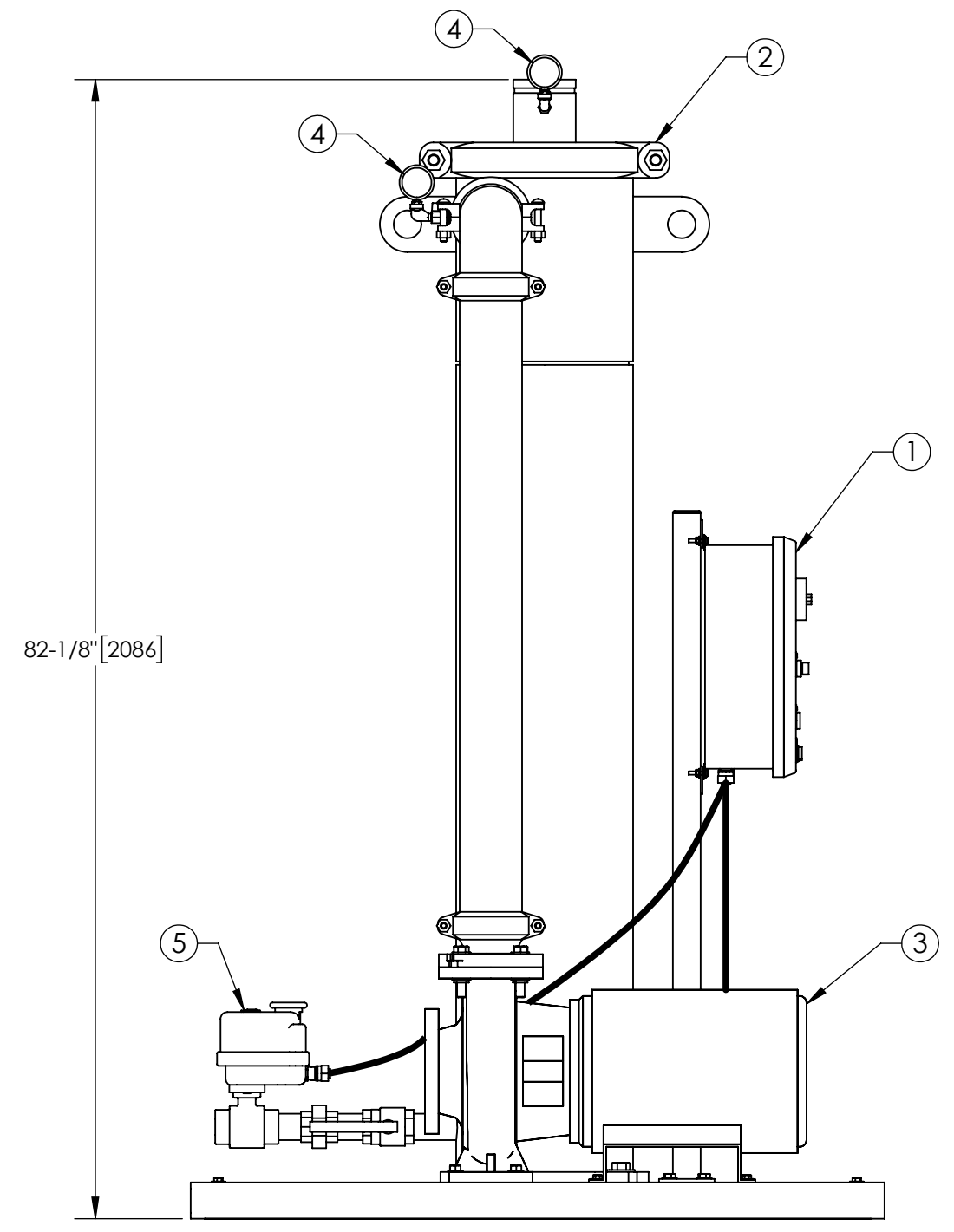
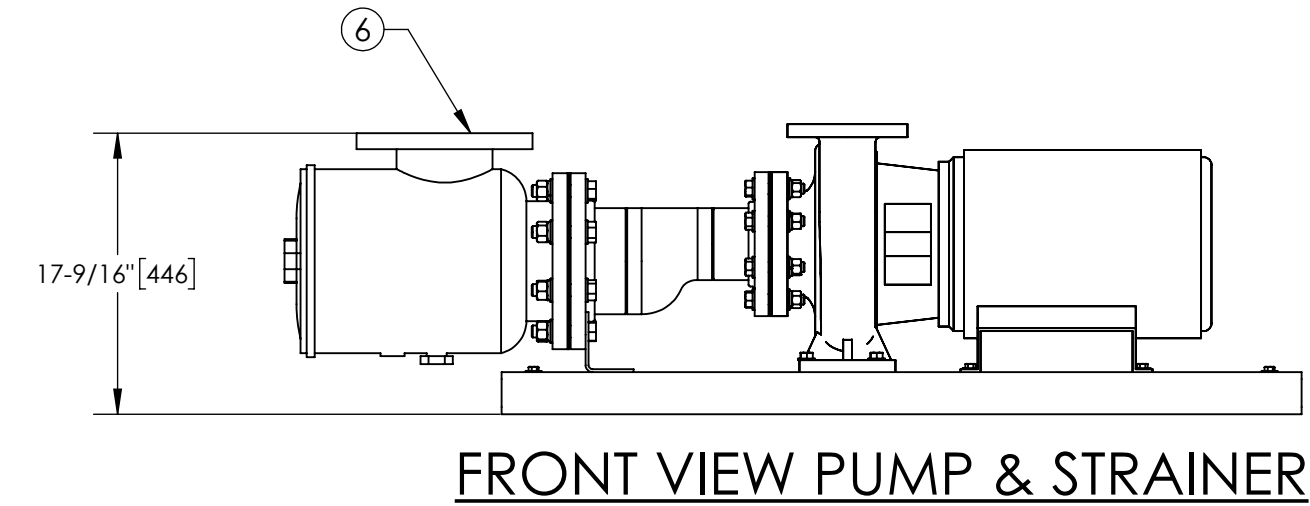
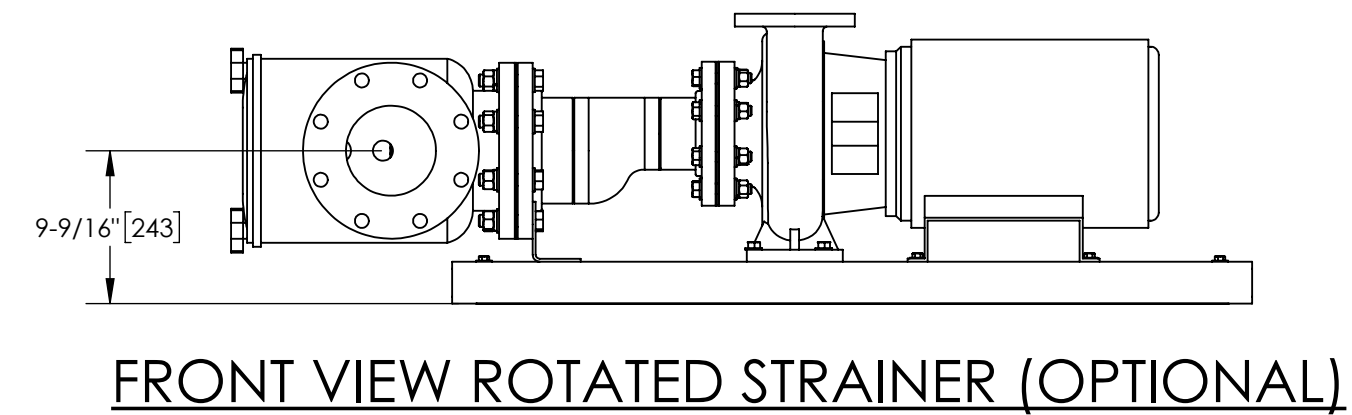

FRONT VIEW W/O STRAINER

UNLESS OTHERWISE SPECIFIED: DIMENSIONS ARE IN: INCHES (mm) TOLERANCES ARE: FRACTIONS DECIMALS ANGLES ± 1" .XX ± .01 ± 1/4" .XXX ± .005 .XXXX ± .0005	ENGINEERED FOR:	STANDARD		FRESNO, CALIFORNIA WWW.LAKOS.COM	
	APPROVALS	DATE	TITLE		
	DRAWN	ENGR	MFG		eTCX-0410-EFS/ACPI TC SYSTEM HI EFF SWEEPER eHTX-0185 3/60/208 230 460V
	DO NOT SCALE DRAWING	ADJ	1/20/21		SIZE C SCALE 1:8
MATERIAL	ENGR	-	-	MODEL NO. DWG NO. 184851 EST. WT. 1557 lb SHEET 1 OF 1	
FINISH	MFG	-	-	REV. A	
PER LAKOS SPEC	WORK ORDER	-	QTY.		

4

3

2

1

DWG NO. 184851
 SHEET 1
 REV. A