

4

2

1

EXCEPT AS OTHERWISE PROVIDED BY CONTRACT, THIS DRAWING AND SPECIFICATIONS SHALL NOT BE REPRODUCED, COPIED OR USED AS THE BASIS FOR MANUFACTURE OR SALE OF MATTER DEPICTED HEREIN WITHOUT THE EXPRESSED WRITTEN PERMISSION OF THE LAKOS CORPORATION, OR ITS ASSIGNEES.

THIS DRAWING HAS BEEN GENERATED AND IS MAINTAINED BY A CAD SYSTEM. CHANGES SHALL ONLY BE INCORPORATED AS DIRECTED BY AN APPROVED ENGINEERING CHANGE ORDER (ECO). PAPER COPIES ARE UNCONTROLLED.

REVISION HISTORY				
ZONE	REV	DESCRIPTION	DATE	APPROVED
	A	RELEASED FOR SUBMITTAL	1/5/21	ADJ

NOTES:

- INLET IS 4" FLANGED (125# ANSI FLANGED).
- OUTLET IS 2-1/2" PIPE (GROOVED).
- PURGE OUTLET IS 3/4" PIPE.
- MAXIMUM PRESSURE: 150 psi (10.3 bar).
- MAXIMUM FLUID OPERATING TEMPERATURE: 100°F (37.8°C).
- MAXIMUM AIR OPERATING TEMPERATURE: 100°F (37.8°C).
- SPECIFIED FLOW RATES:
 BASIN SWEEPING - 160 gpm (36 m³/hr).
 SIDE STREAM & CLOSED LOOP- 210 gpm (48 m³/hr).
- FINISH: AS ASSEMBLED.
- POWER REQUIREMENT: 3/60/208 230 460V
- NEMA 4X MOTOR STARTER ENCLOSURE WITH SAFETY DISCONNECT AND H.O.A. SWITCH.
- APPROXIMATE DRY WEIGHT: 774 lbs (351 kg).
- INLET/OUTLET VALVE KIT RECOMMENDED: SEE FACTORY.
- MINIMUM PIPE FROM TOWER BASIN TO TC SYSTEM IS 4" PIPE.
- FLOODED SUCTION REQUIRED.

System Part Numbers	Electrical Box	Power Requirements
184842-208V	184628	3/60/208V
184842-230V	184632	3/60/230V
184842-460V	129026	3/60/460V

COMPONENT LIST:

- ELECTRICAL CONTROL BOX 3/60/208 230 460V W/120V TRANSFORMER.
- SEPARATOR: eHTX-0080-V.
- PUMP: 5 HP CENTRIFUGAL, 1750 rpm, 3/60/208 230 460V.
- INLET/OUTLET PRESSURE GAUGES: 0-160 psi, GLYCERIN-FILLED.
- PURGE EQUIPMENT: EFS-07-120V.
- STRAINER SUCTION DIFFUSER.

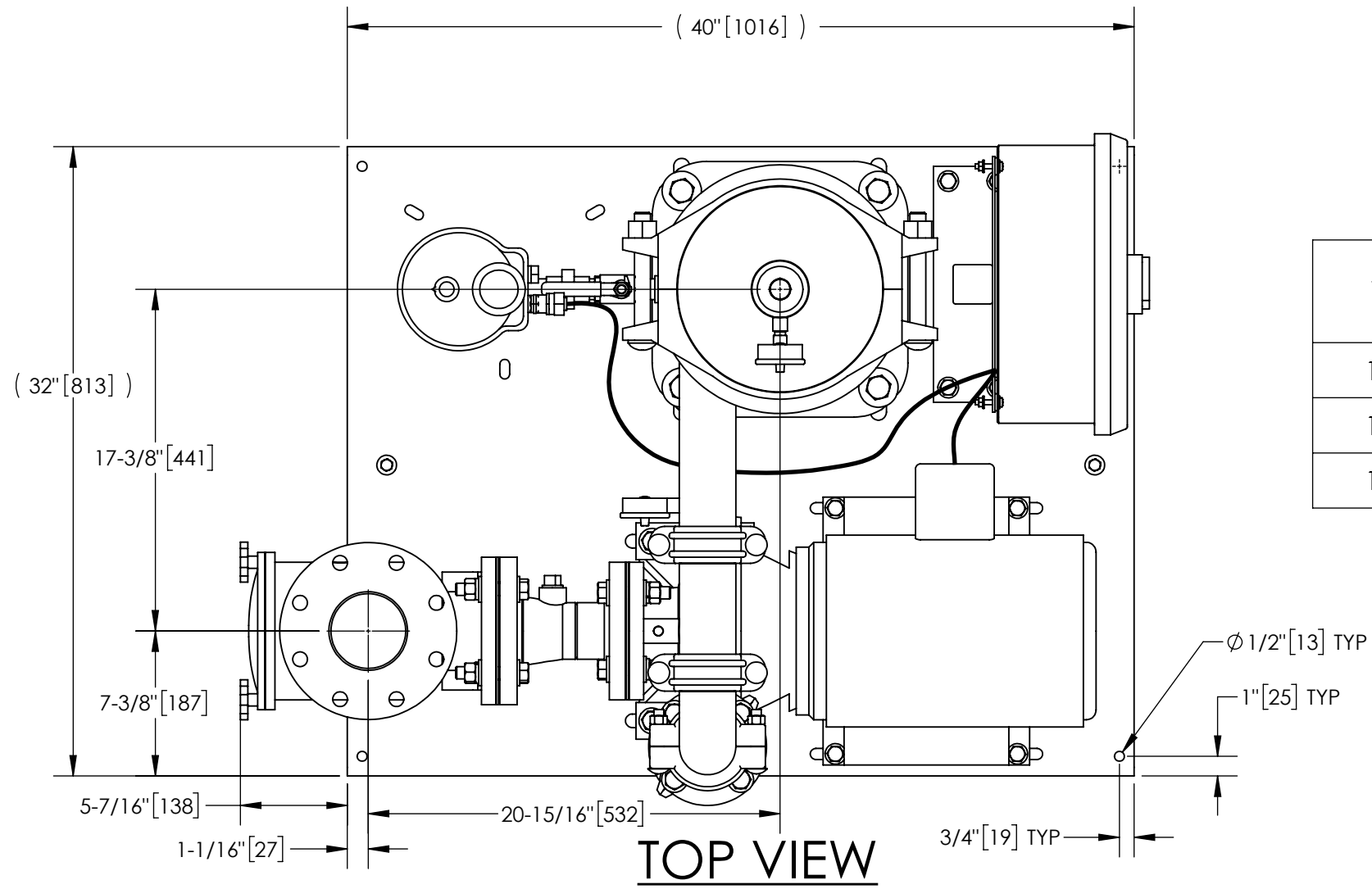

SUBMITTAL DRAWING

This drawing is submitted for spatial consideration only. Do not pre-plumb to these dimensions.

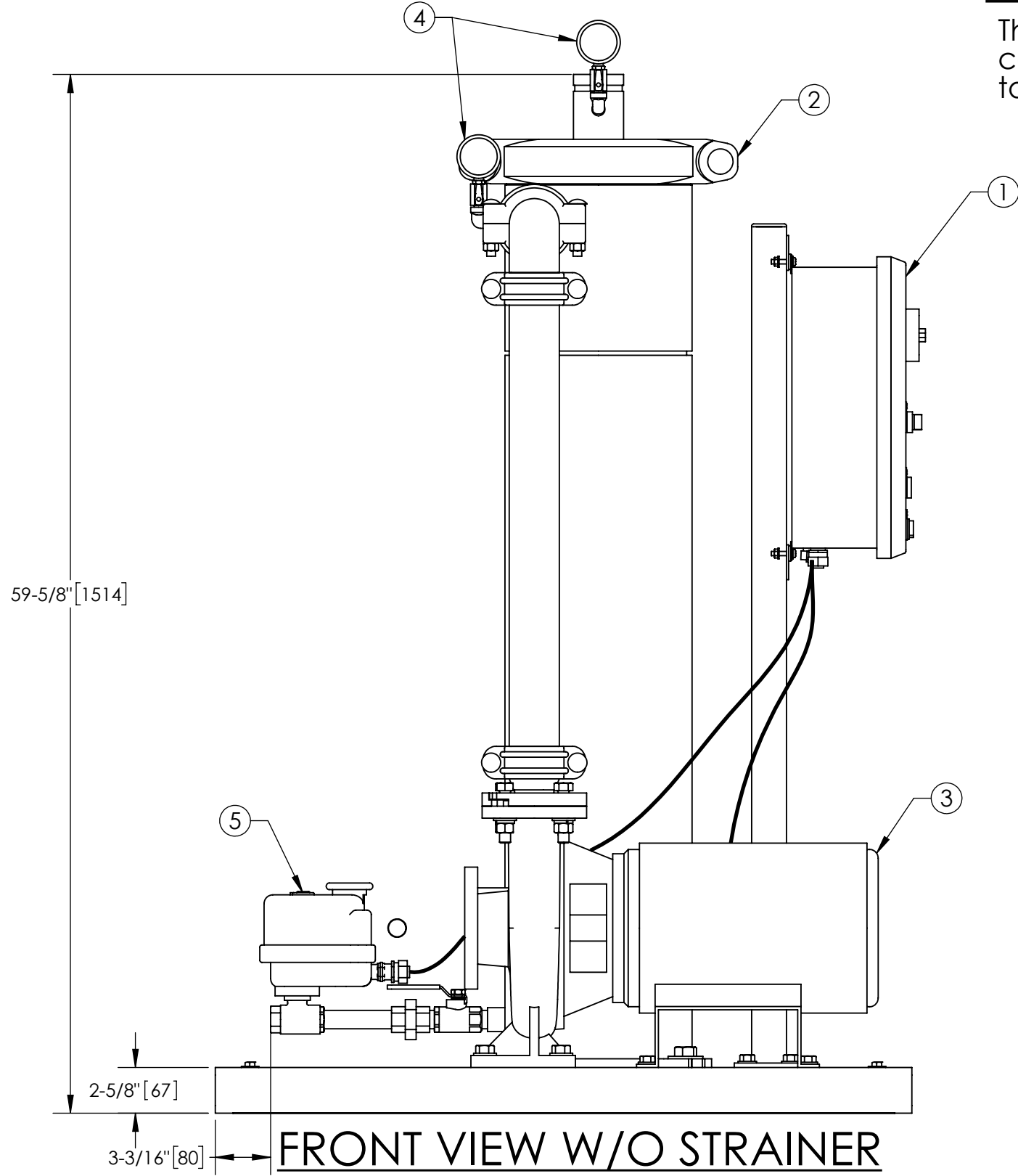
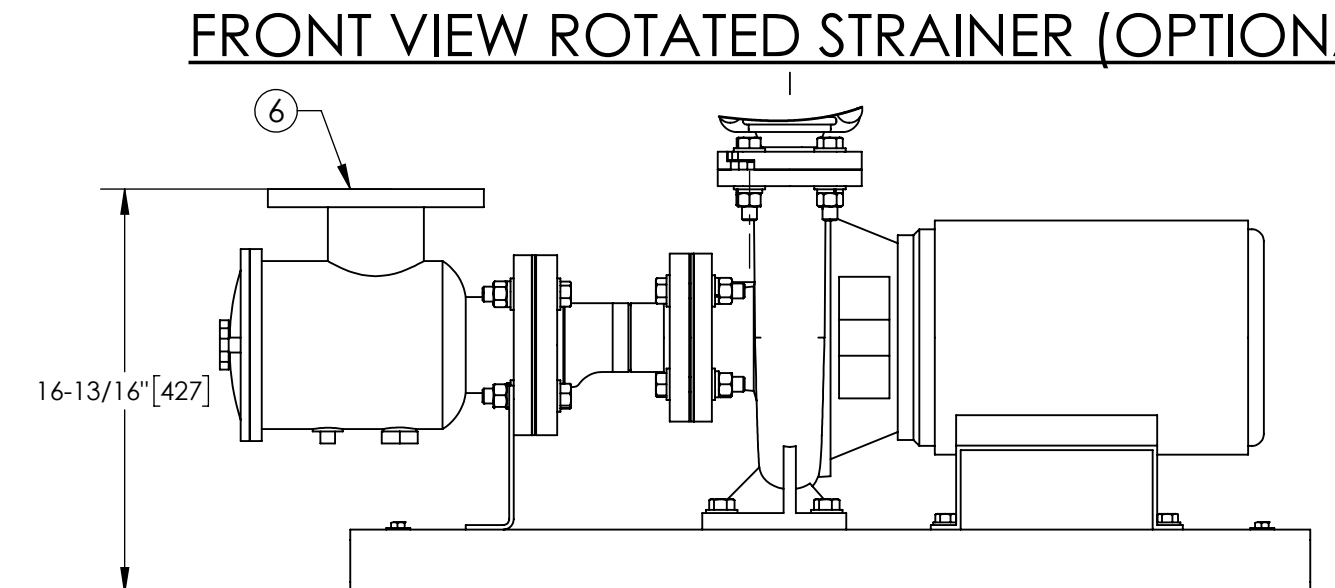
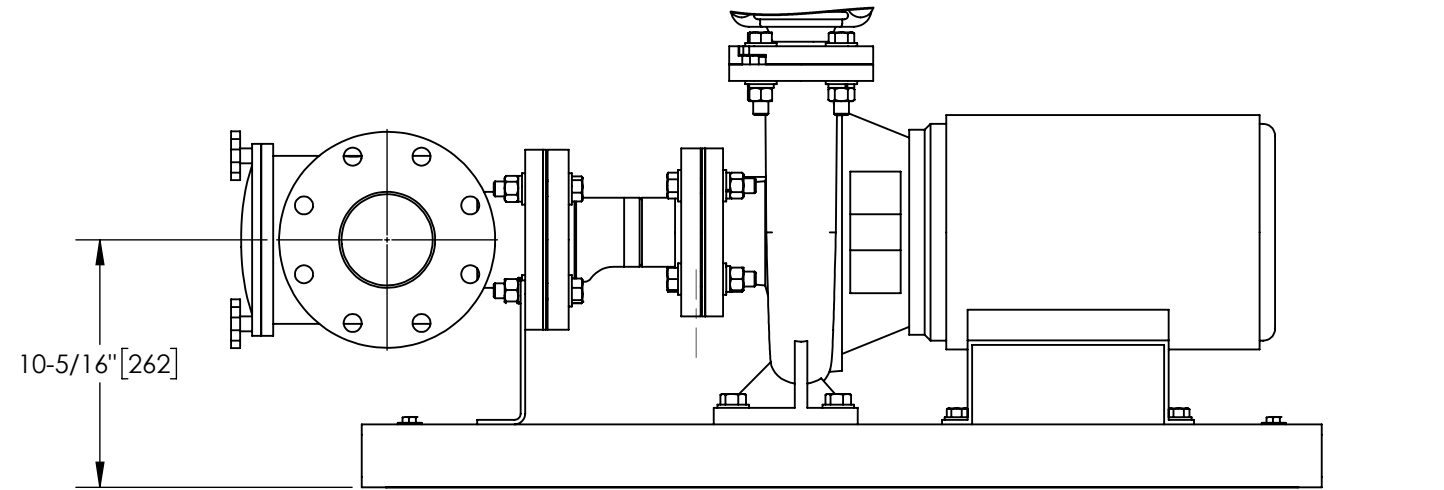

UNLESS OTHERWISE SPECIFIED: DIMENSIONS ARE IN: INCHES [mm] TOLERANCES ARE: FRACTIONS DECIMALS ANGLES $\pm 1"$.XX $\pm .01$ $\pm 1/4"$.XXX $\pm .005$.XXXX $\pm .0005$		ENGINEERED FOR: STANDARD		FRESNO, CALIFORNIA WWW.LAKOS.COM	
DO NOT SCALE DRAWING	APPROVALS	DATE	TITLE		
MATERIAL PER LAKOS SPEC	DRAWN ADJ	1/5/21	eTCX-0160-EFS/ACP1 TC SYSTEM HI EFF SWEEPER eHTX-0080 3/60/208 230 460V		
FINISH AS ASSEMBLED	ENGR	-	SIZE C	MODEL NO.	DWG NO.
	MFG	-	SCALE 1:8		184842
	WORK ORDER	QTY.		EST. WT.	774 lb
				SHEET	1 OF 1

4

3

2

1

DWG NO. 184842
SHEET 1
REV. A