

EXCEPT AS OTHERWISE PROVIDED BY CONTRACT, THIS DRAWING AND SPECIFICATIONS SHALL NOT BE REPRODUCED, COPIED OR USED AS THE BASIS FOR MANUFACTURE OR SALE OF MATTER DEPICTED HEREIN WITHOUT THE EXPRESSED WRITTEN PERMISSION OF THE LAKOS CORPORATION, OR ITS ASSIGNEES.

THIS DRAWING HAS BEEN GENERATED AND IS MAINTAINED BY A CAD SYSTEM. CHANGES SHALL ONLY BE INCORPORATED AS DIRECTED BY AN APPROVED ENGINEERING CHANGE ORDER (ECO). PAPER COPIES ARE UNCONTROLLED.

REVISION HISTORY				
ZONE	REV	DESCRIPTION	DATE	APPROVED
	01	RELEASE SUBMITTAL	12/27/20	ADJ

NOTES:

- INLET IS 2-1/2" PIPE (125# ANSI FLANGED).
- OUTLET IS 1-1/2" PIPE (GROOVED).
- PURGE OUTLET IS 3/4" PIPE.
- MAXIMUM PRESSURE: 150 psi (10.3 bar).
- MAX FLUID OPERATING TEMPERATURE: 100°F (37.8°C).
MAX AIR OPERATING TEMPERATURE: 100°F (37.8°C).
- SPECIFIED FLOW RATES:
BASIN SWEEPING- 80 gpm (18 m³/hr).
SIDE STREAM & CLOSED LOOP- 95 gpm (22 m³/hr).
- FINISH: AS ASSEMBLED.
- POWER REQUIREMENT: 208V/230V/460V, 3PH, 60Hz. (CUSTOMER SPECIFIED)
- NEMA 4X MOTOR STARTER ENCLOSURE WITH SAFETY DISCONNECT AND H.O.A. SWITCH.
- APPROXIMATE DRY WEIGHT: 655 lbs (297 kg).
- INLET/OUTLET VALVE KIT RECOMMENDED: SEE FACTORY.
- MINIMUM PIPE FROM TOWER BASIN TO TC SYSTEM IS 2-1/2" PIPE.
- FLOODED SUCTION REQUIRED.

COMPONENT LIST:

- ELECTRICAL CONTROL BOX 208V/230V/460V, 60Hz W/120V TRANSFORMER.
- SEPARATOR: eHTX-0040-V.
- PUMP: 3 HP CENTRIFUGAL, 3600 rpm, 208V/230V/460V, 60Hz.
- INLET/OUTLET PRESSURE GAUGES: 160 psi, GLYCERIN-FILLED.
- PURGE EQUIPMENT: EFS-07-120V.
- STRAINER, SUCTION DIFFUSER.

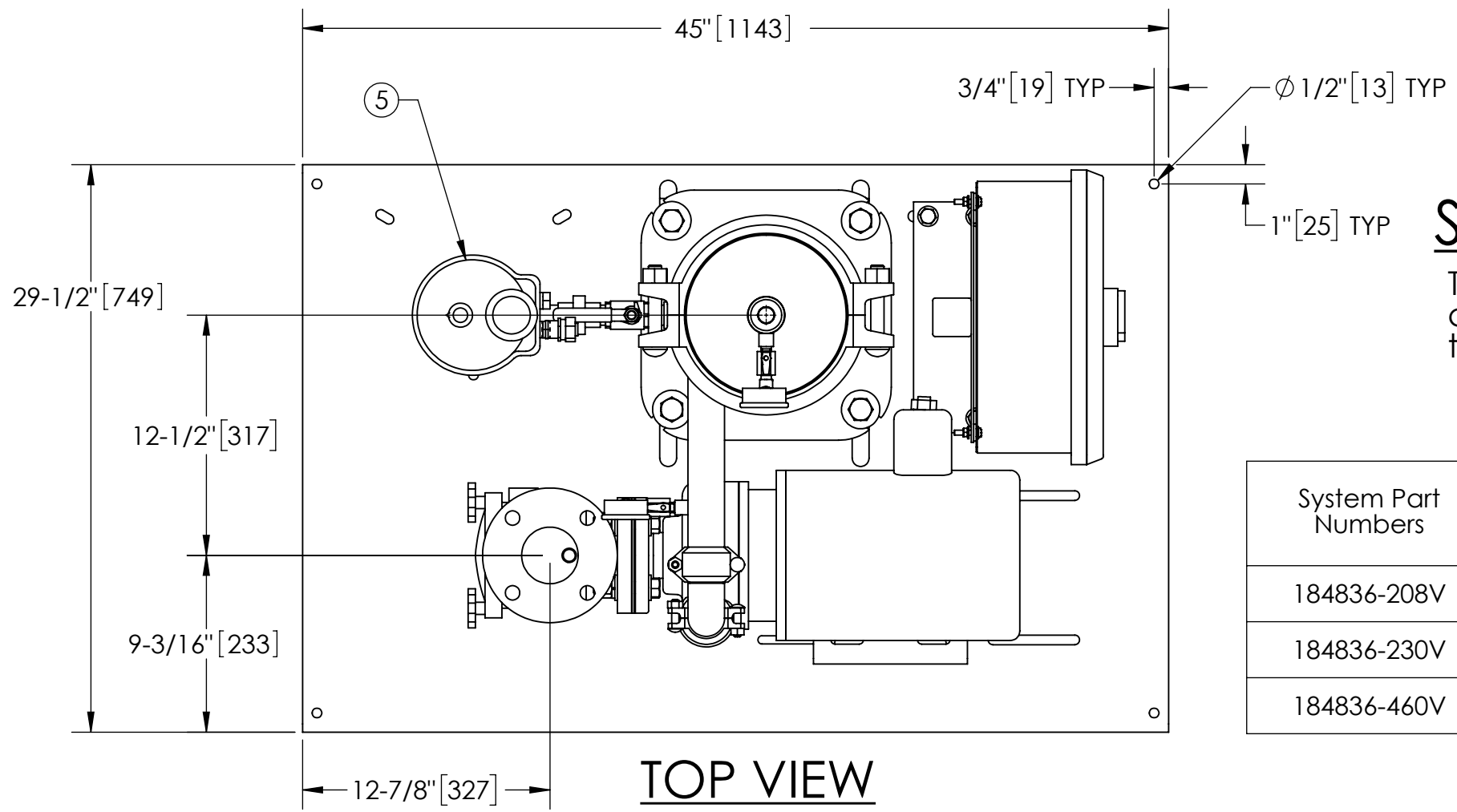

SUBMITTAL DRAWING

This drawing is submitted for spatial consideration only. Do not pre-plumb to these dimensions.

System Part Numbers	Electrical Box	Power Requirements
184836-208V	184628	3/60/208V
184836-230V	184632	3/60/230V
184836-460V	184635	3/60/460V

TOP VIEW

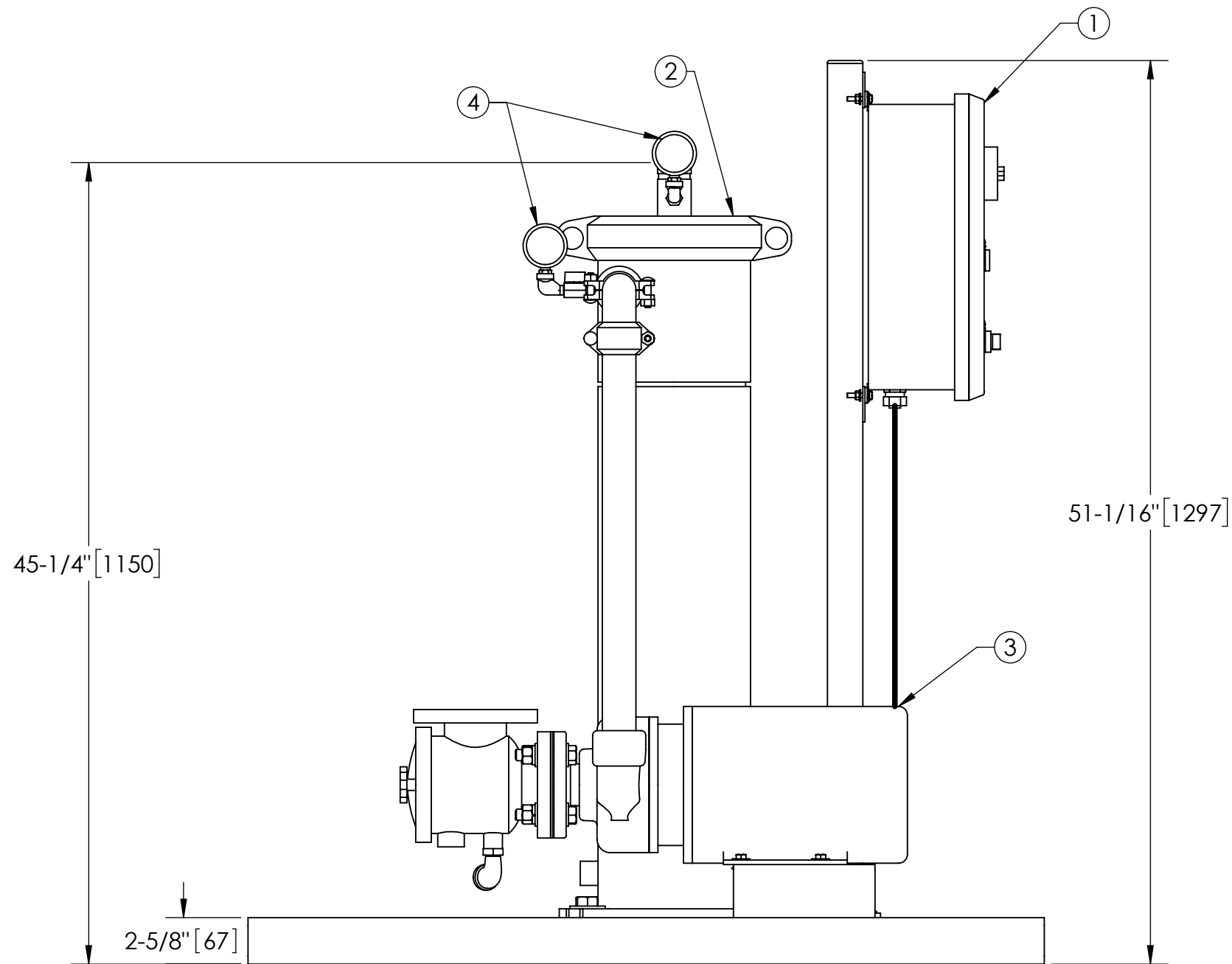

FRONT VIEW W/O STRAINER

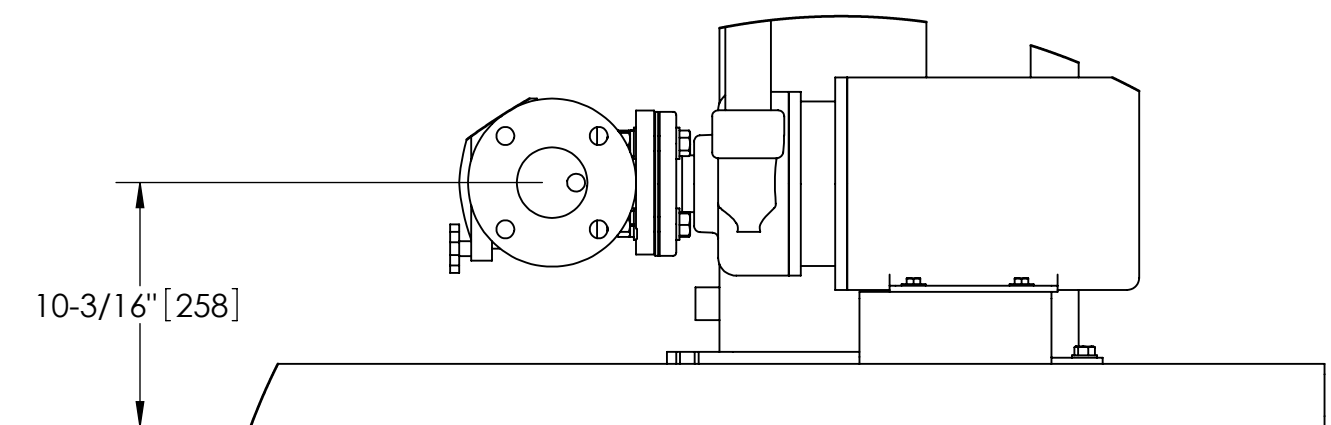

FRONT VIEW ROTATED STRAINER

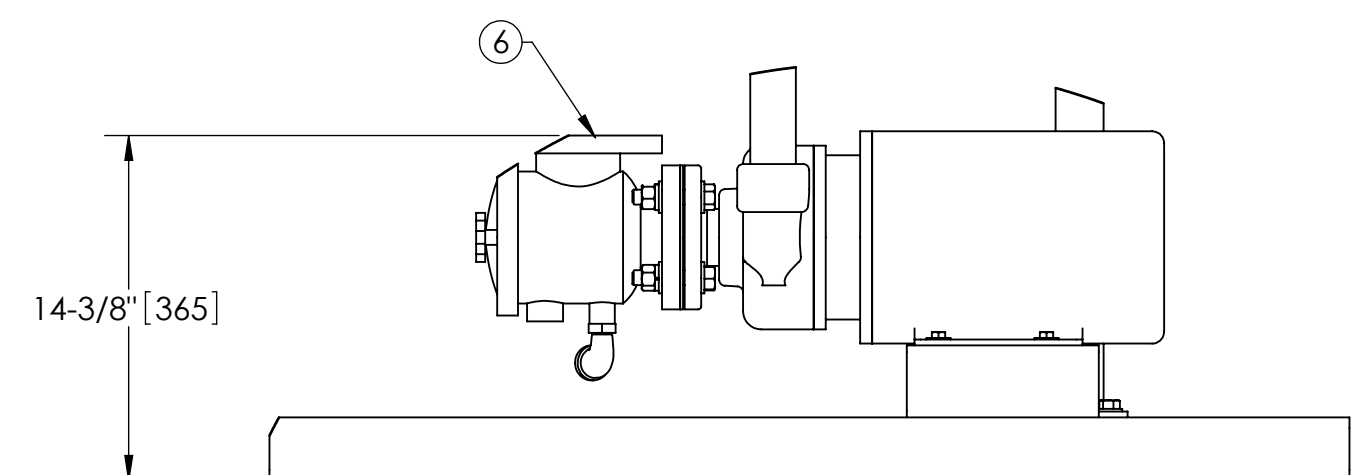

FRONT VIEW PUMP & STRAINER

UNLESS OTHERWISE SPECIFIED: DIMENSIONS ARE IN: INCHES (mm) TOLERANCES ARE: FRACTIONS .XX ± .01 ANGLES ± 1/4° ± 1" .XXX ± .005 .XXXX ± .0005		ENGINEERED FOR: STANDARD			
DO NOT SCALE DRAWING		APPROVALS	DATE	TITLE	
MATERIAL PER LAKOS SPEC		DRAWN ADJ	12/27/20	eTCX-0080-EFS/ACP1 TC SYSTEM	
FINISH AS ASSEMBLED		ENGR -	-	HI EFF SWEEPER eHTX-0040 3/60/208 230 460V	
WORK ORDER		MFG -	-	SIZE C	MODEL NO.
		WORK ORDER	QTY.	DWG NO. 184836	REV. A
				SCALE 1:8	EST. WT. 655 lb SHEET 1 OF 1

DWG. NO. 184836 SHEET REV. A