

EXCEPT AS OTHERWISE PROVIDED BY CONTRACT, THIS DRAWING AND SPECIFICATIONS SHALL NOT BE REPRODUCED, COPIED OR USED AS THE BASIS FOR MANUFACTURE OR SALE OF MATTER DEPICTED HEREIN WITHOUT THE EXPRESSED WRITTEN PERMISSION OF THE LAKOS CORPORATION, OR ITS ASSIGNEES.

THIS DRAWING HAS BEEN GENERATED AND IS MAINTAINED BY A CAD SYSTEM. CHANGES SHALL ONLY BE INCORPORATED AS DIRECTED BY AN APPROVED ENGINEERING CHANGE ORDER (ECO). PAPER COPIES ARE UNCONTROLLED.

| REVISION HISTORY |     |                        |         |          |
|------------------|-----|------------------------|---------|----------|
| ZONE             | REV | DESCRIPTION            | DATE    | APPROVED |
|                  | 01  | RELEASED FOR SUBMITTAL | 1/27/21 | AAM      |

**NOTES:**

1. INLET IS 8" PIPE (125# ANSI FLANGED).
2. OUTLET IS 6" PIPE (GROOVED).
3. PURGE OUTLET IS 1-1/2" PIPE.
4. MAXIMUM PRESSURE: 150 psi (10.3 bar).
5. MAXIMUM FLUID TEMPERATURE: 100°F (37.8°C).  
MAXIMUM AMBIENT AIR TEMPERATURE: 100°F (37.8°C).
6. SPECIFIED FLOWRATE OF 910 gpm (207 m³/hr).
7. FINISH: AS ASSEMBLED.
8. POWER REQUIREMENT: 3/60/230,460V. (CUSTOMER SPECIFIED)
9. NEMA 4X MOTOR STARTER ENCLOSURE WITH SAFETY DISCONNECT AND H.O.A. SWITCH.
10. APPROXIMATE DRY WEIGHT: 2534 lbs (1149kg).
11. INLET/OUTLET VALVE KIT RECOMMENDED: SEE FACTORY.
12. MINIMUM PIPE FROM TOWER BASIN TO TC SYSTEM IS 8" PIPE.
13. FLOODED SUCTION REQUIRED.

**COMPONENT LIST:**

- ① ELECTRICAL CONTROL BOX 3/60/230,460V W/120V TRANSFORMER.
- ② SEPARATOR: eHTX-0320-L-TC.
- ③ PUMP: 25 HP CENTRIFUGAL, 1800 rpm, 3/60/230,460V.
- ④ INLET/OUTLET PRESSURE GAUGES: 0-160 psi, GLYCERIN-FILLED.
- ⑤ PURGE EQUIPMENT: EFS-15-120V.
- ⑥ STRAINER, SUCTION DIFFUSER (DIFFUSER SUPPORT WILL NOT BE SUPPLIED BY LAKOS)

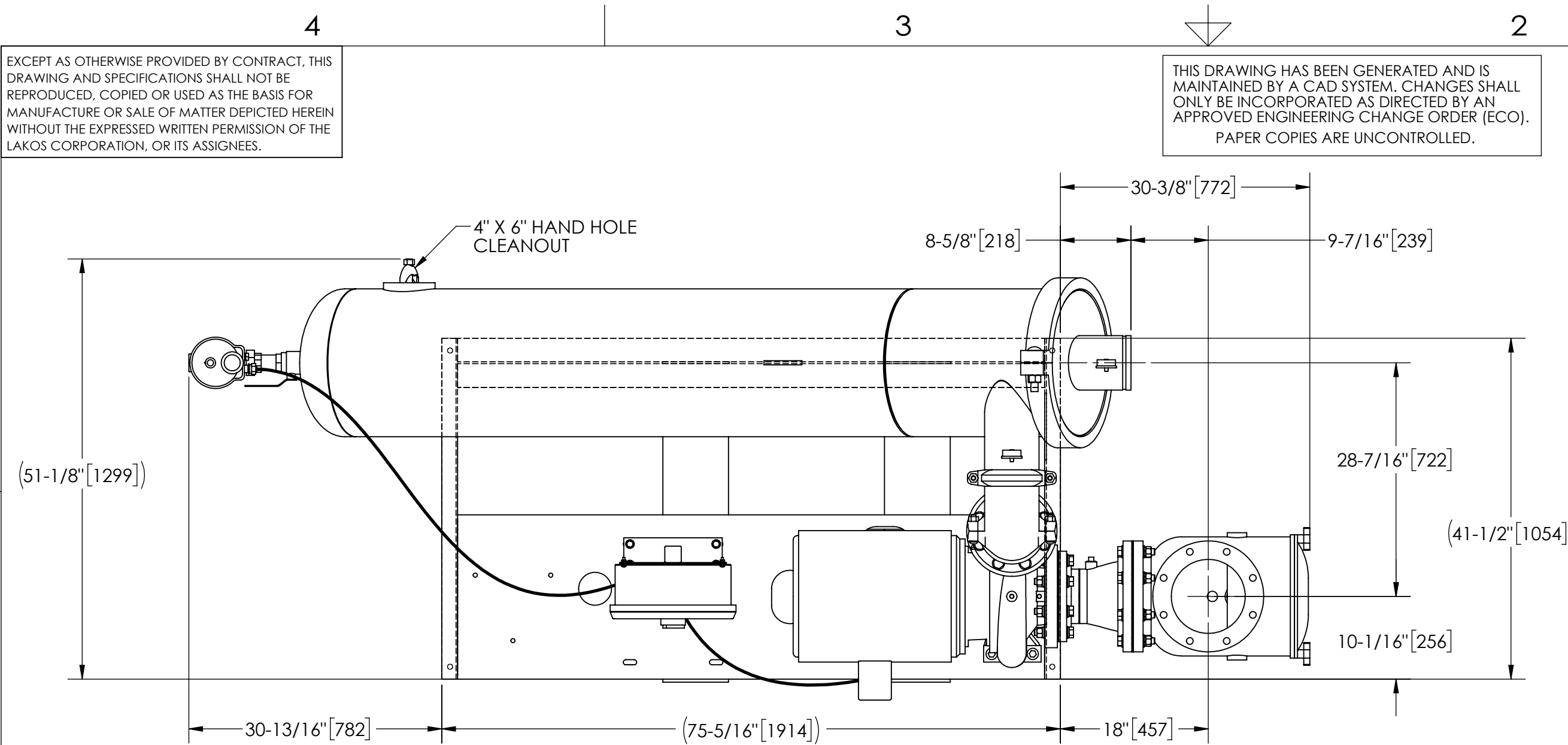

**SUBMITTAL DRAWING**

**TOP VIEW**

This drawing is submitted for spatial consideration only. Do not pre-plumb to these dimensions.

|            |                          |
|------------|--------------------------|
| 184855-230 | FOR OTHER VOLTAGES ORDER |
| 184855-460 | SHOWN                    |

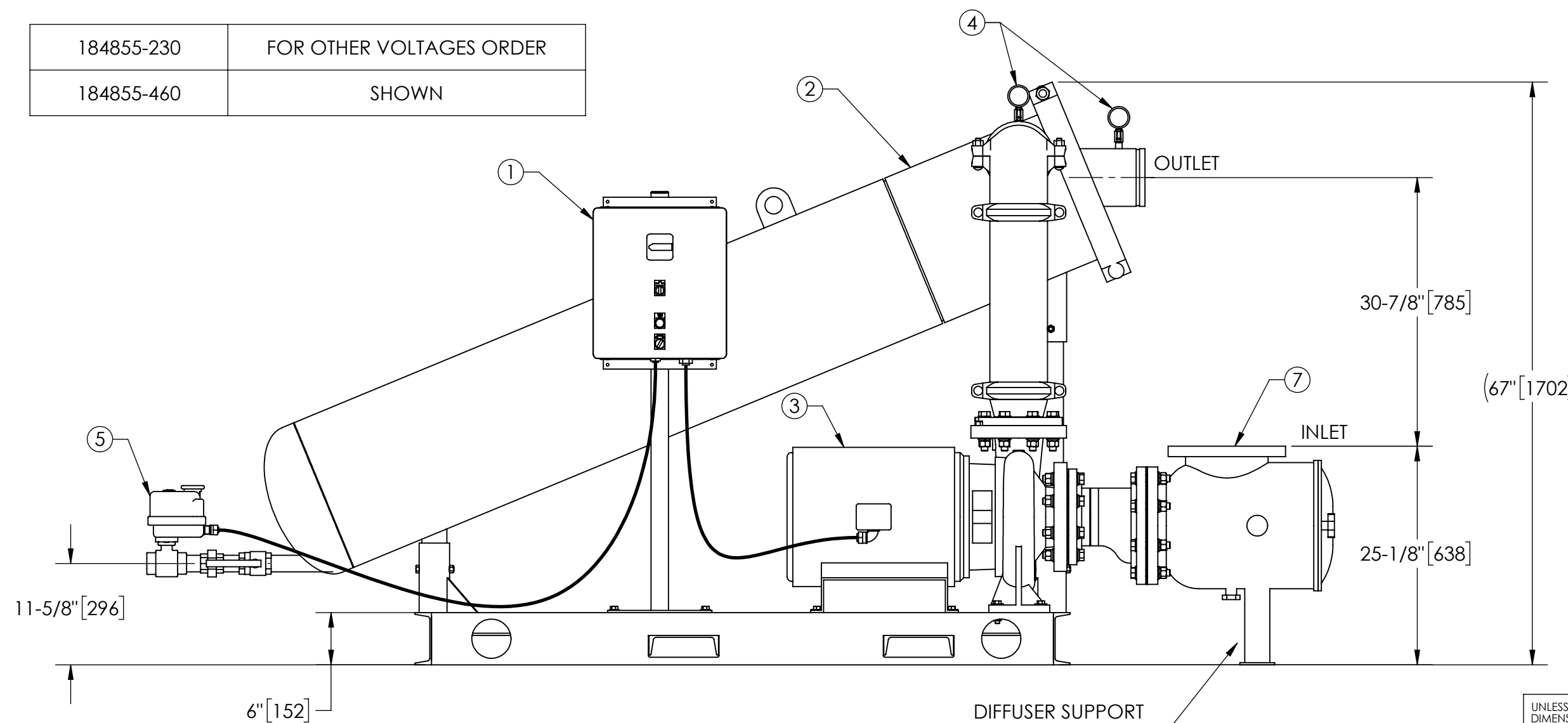

**SIDE VIEW**

DIFFUSER SUPPORT WILL NOT BE SUPPLIED BY LAKOS

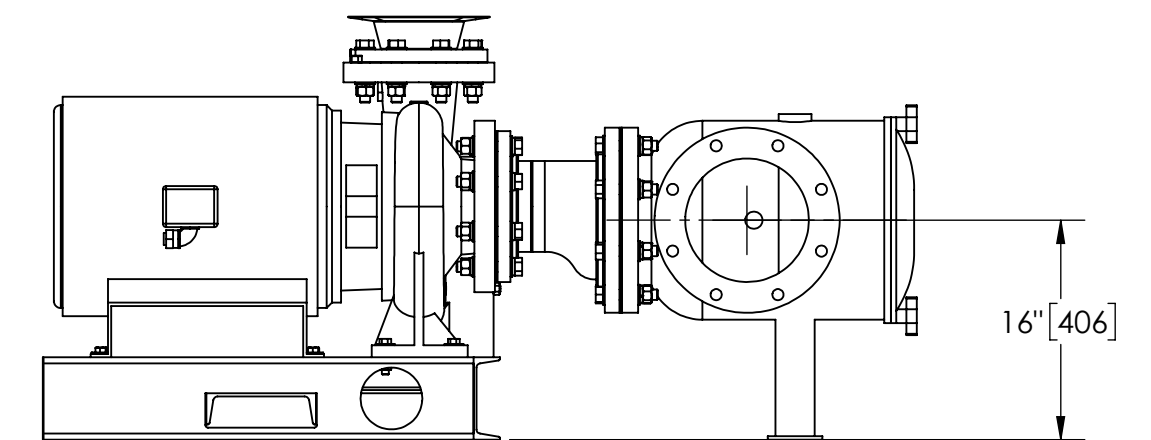

**SIDE VIEW ROTATED STRAINER (OPTIONAL)**

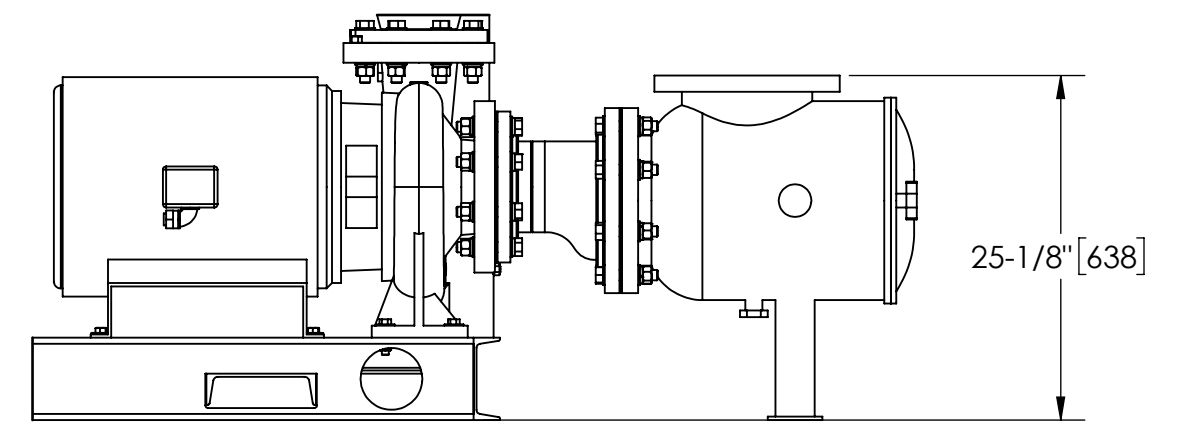

**SIDE VIEW PUMP & STRAINER**

|   |            |                                    |   |                  |                |
|---|------------|------------------------------------|---|------------------|----------------|
| UNLESS OTHERWISE SPECIFIED: DIMENSIONS ARE IN: INCHES (mm)<br>TOLERANCES ARE:<br>FRACTIONS DECIMALS ANGLES<br>± 1" .XX ± .01 ± 1/4"<br>.XXX ± .005<br>.XXXX ± .0005 |            | ENGINEERED FOR:<br><b>STANDARD</b> |   |                  |                |
| DO NOT SCALE DRAWING  | APPROVALS  | DATE                               | TITLE   |                  |                |
| MATERIAL PER LAKOS SPEC   | DRAWN AAM  | 1/27/21                            | eTCX-0910-EFS/ACP1, TC SYSTEM,<br>HI EFF SWEEPER eHTX-0320, 3/60/230,460V |                  |                |
| FINISH AS ASSEMBLED   | ENGR -     | -                                  | SIZE C  | MODEL NO.        | DWG NO. 184855 |
|   | REVIEW -   | -                                  | SCALE 1:14  | EST. WT. 2534 lb | REV. 01        |
|   | WORK ORDER | QTY.                               |   | SHEET 1 OF 1     |                |

DWG NO. 184855  
SHT 1  
REV. 01