

EXCEPT AS OTHERWISE PROVIDED BY CONTRACT, THIS DRAWING AND SPECIFICATIONS SHALL NOT BE REPRODUCED, COPIED OR USED AS THE BASIS FOR MANUFACTURE OR SALE OF MATTER DEPICTED HEREIN WITHOUT THE EXPRESSED WRITTEN PERMISSION OF THE LAKOS CORPORATION, OR ITS ASSIGNEES.

THIS DRAWING HAS BEEN GENERATED AND IS MAINTAINED BY A CAD SYSTEM. CHANGES SHALL ONLY BE INCORPORATED AS DIRECTED BY AN APPROVED ENGINEERING CHANGE ORDER (ECO). PAPER COPIES ARE UNCONTROLLED.

REVISION HISTORY				
ZONE	REV	DESCRIPTION	DATE	APPROVED
	01	RELEASED FOR SUBMITTAL	11/27/20	AAM

NOTES:

- INLET IS 3" PIPE (125# ANSI FLANGED).
- OUTLET IS 2" PIPE (GROOVED).
- PURGE OUTLET IS 3/4" PIPE.
- MAXIMUM PRESSURE: 150 psi (10.3 bar).
- MAXIMUM FLUID TEMPERATURE: 100°F (37.8°C).
MAXIMUM AMBIENT AIR TEMPERATURE: 100°F (37.8°C).
- SPECIFIED FLOW RATES:
BASIN SWEEPING- 110 gpm (25 m³/hr).
SIDE STREAM & CLOSED LOOP- 140 gpm (32 m³/hr).
- FINISH: AS ASSEMBLED.
- POWER REQUIREMENT: 3/60/208-230,460V.(CUSTOMER SPECIFIED)
- NEMA 4X MOTOR STARTER ENCLOSURE WITH SAFETY DISCONNECT AND H.O.A. SWITCH.
- APPROXIMATE DRY WEIGHT: 737 lbs (334 kg).
- INLET/OUTLET VALVE KIT RECOMMENDED: SEE FACTORY.
- MINIMUM PIPE FROM TOWER BASIN TO TC SYSTEM IS 3" PIPE.
- FLOODED SUCTION REQUIRED.

COMPONENT LIST:

- ELECTRICAL CONTROL BOX: 3/60/208-230,460V W/120V TRANSFORMER.
- SEPARATOR: eHTX-0060-V.
- PUMP: 3 HP CENTRIFUGAL, 1800 rpm, 3/60/208-230,460V.
- INLET/OUTLET PRESSURE GAUGES: 160 psi, GLYCERIN-FILLED.
- PURGE EQUIPMENT: SRV-0833 & EFS-07-120V.
- DIFFERENTIAL PRESSURE INDICATOR:
(AVAILABLE WITH DRY ELECTRICAL CONTACT-MODEL DHE-15-S. ORDER SEPARATELY).
- STRAINER, SUCTION DIFFUSER.

SUBMITTAL DRAWING

This drawing is submitted for spatial consideration only. Do not pre-plumb to these dimensions.

184840-208V	FOR OTHER VOLTAGES ORDER
184840-230V	FOR OTHER VOLTAGES ORDER
184840-460V	SHOWN

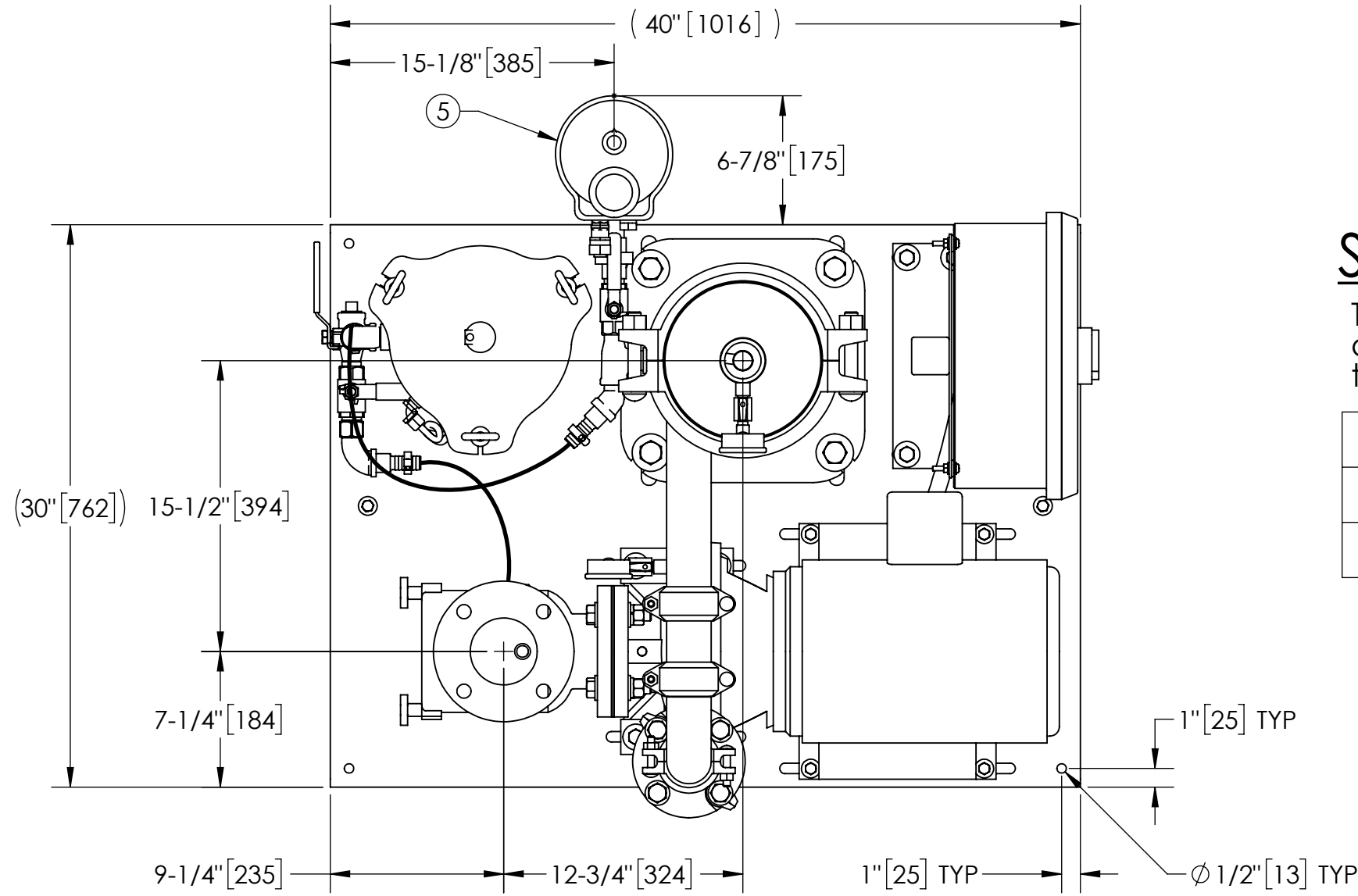

TOP VIEW

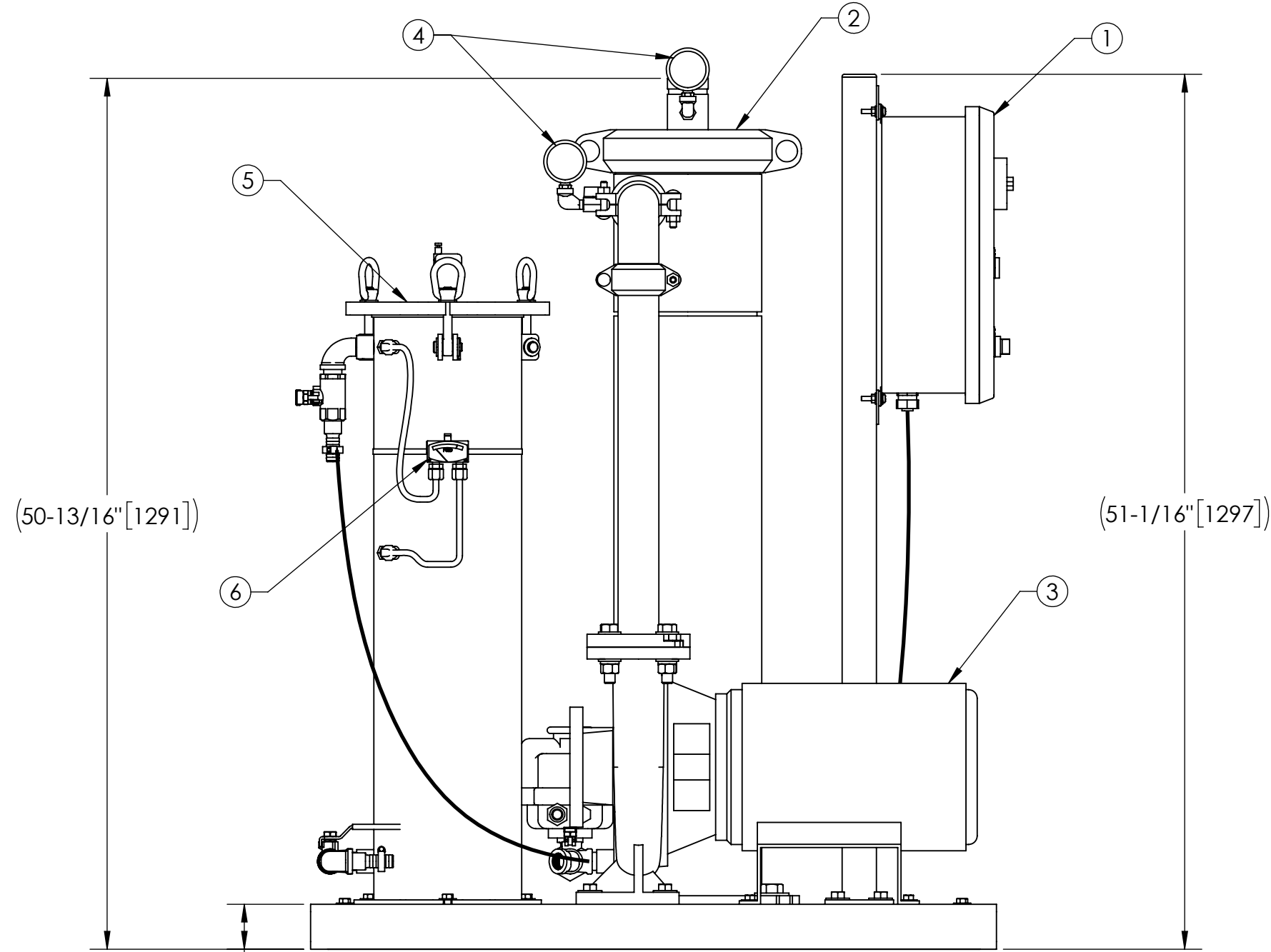

FRONT VIEW W/O STRAINER

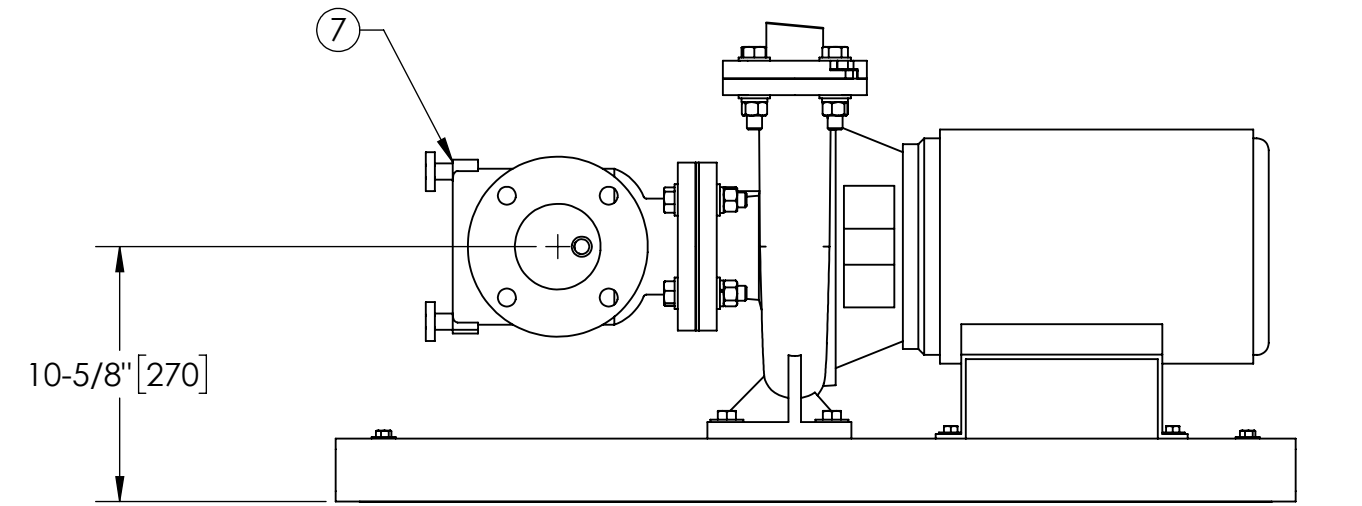

FRONT VIEW W/ROTATED STRAINER

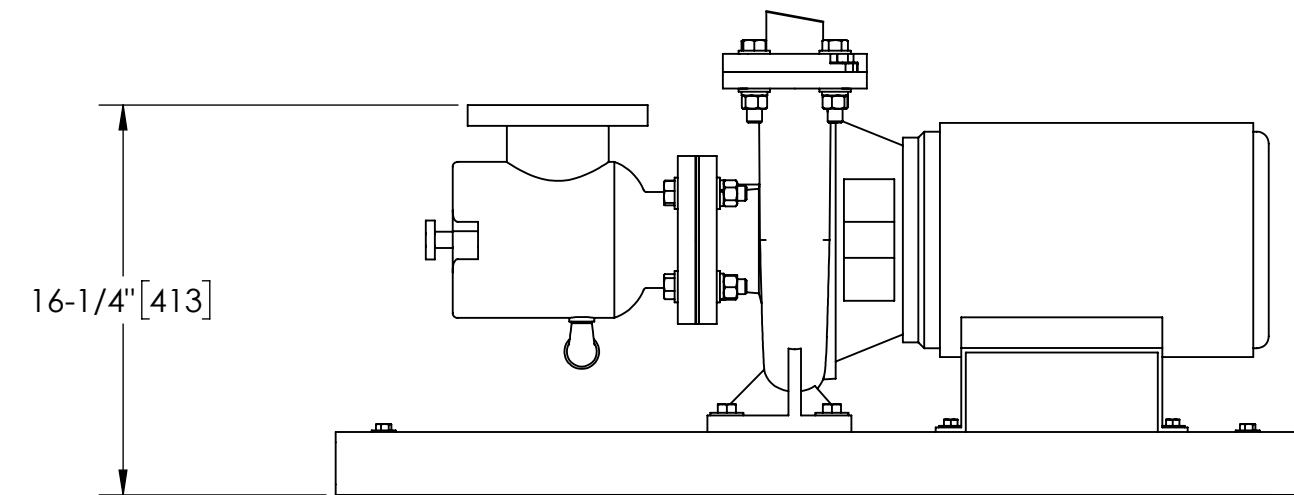

FRONT VIEW W/STRAINER

UNLESS OTHERWISE SPECIFIED: DIMENSIONS ARE IN: INCHES (mm) TOLERANCES ARE: FRACTIONS .XX ± .01 ± 1/4" DECIMALS .XXX ± .005 ANGLES ± 1/4° XXX ± .0005	ENGINEERED FOR: STANDARD				
	APPROVALS	DATE			
	DO NOT SCALE DRAWING	DRAWN AAM	11/25/20	TITLE eTCX-0110-SRV/EFS/ACPI, TC SYSTEM, HI EFF SWEEPER eHTX-0060, 3/60/208-230,460V	
	MATERIAL PER LAKOS SPEC	ENGR -	-	SIZE C	MODEL NO.
FINISH AS ASSEMBLED	REVIEW -	-	SCALE 1:8	DWG NO. 184840	REV. 01
	WORK ORDER	QTY.	EST. WT. 737 lb	SHEET 1 OF 1	

DWG. NO. 184840 SHEET 1 REV. 01