

EXCEPT AS OTHERWISE PROVIDED BY CONTRACT, THIS DRAWING AND SPECIFICATIONS SHALL NOT BE REPRODUCED, COPIED OR USED AS THE BASIS FOR MANUFACTURE OR SALE OF MATTER DEPICTED HEREIN WITHOUT THE EXPRESSED WRITTEN PERMISSION OF THE CLAUDE LAVAL CORPORATION, OR ITS ASSIGNEES.

THIS DRAWING HAS BEEN GENERATED AND IS MAINTAINED BY A CAD SYSTEM. CHANGES SHALL ONLY BE INCORPORATED AS DIRECTED BY AN APPROVED ENGINEERING CHANGE ORDER (ECO). PAPER COPIES ARE UNCONTROLLED.

REVISION HISTORY				
ZONE	REV	DESCRIPTION	DATE	APPROVED
	A	RELEASE SUBMITTAL	12/10/20	ADJ

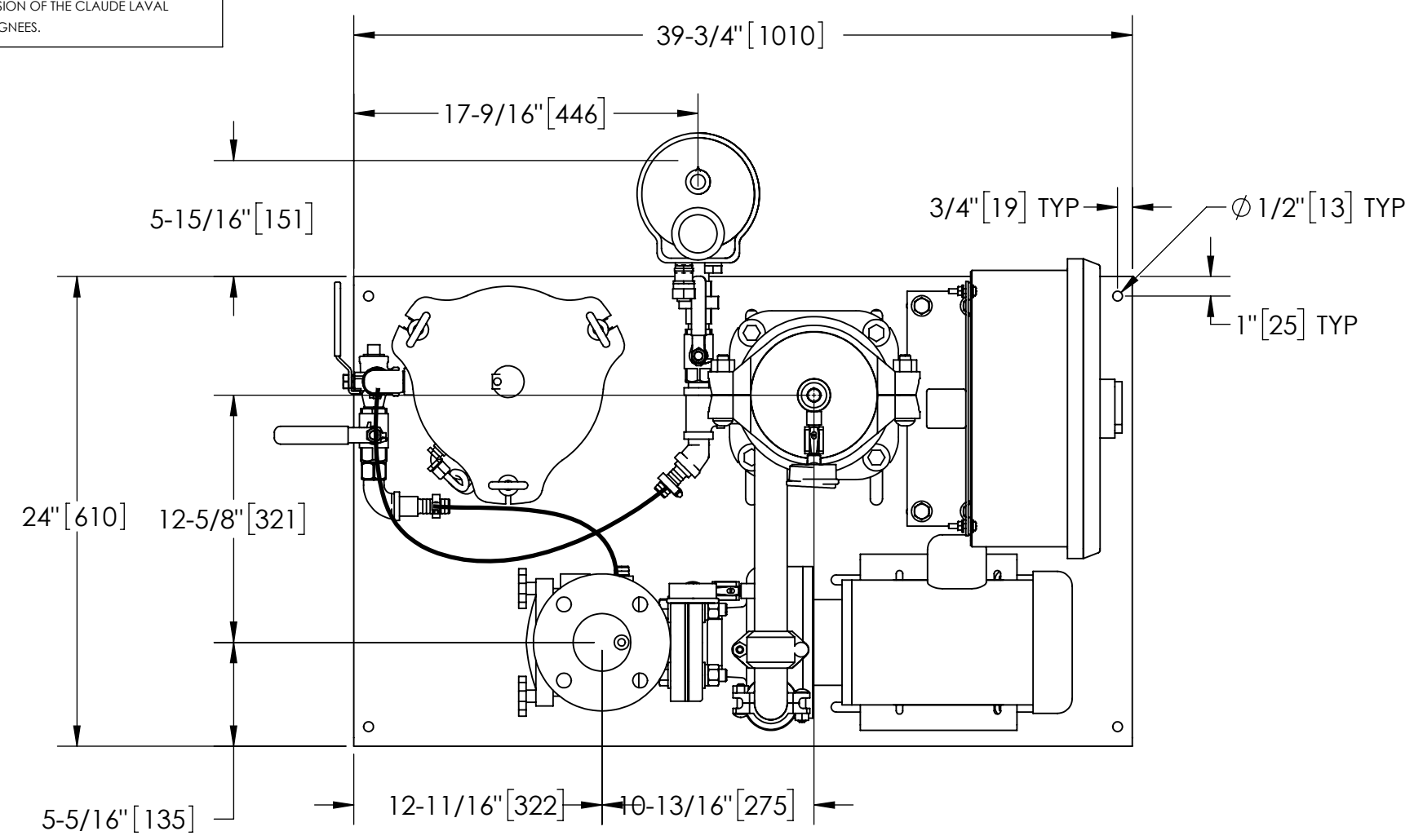

**TOP VIEW**

**NOTES:**

1. INLET IS 2-1/2" PIPE (125# ANSI FLANGED).
2. OUTLET IS 1-1/4" PIPE (GROOVED).
3. PURGE OUTLET IS 3/4" PIPE.
4. MAXIMUM PRESSURE: 150 psi (10.3 bar).
5. MAXIMUM TEMPERATURE: 100°F (37.8°C).
6. SPECIFIED FLOWRATE OF 50 gpm (11.3 m³/hr).
7. FINISH: AS ASSEMBLED.
8. POWER REQUIREMENT: 460V, 3PH, 60Hz.
9. NEMA 4X MOTOR STARTER ENCLOSURE WITH SAFETY DISCONNECT AND H.O.A. SWITCH.
10. APPROXIMATE DRY WEIGHT: 535 lbs (243 kg).
11. INLET/OUTLET VALVE KIT RECOMMENDED: SEE FACTORY.
12. MINIMUM PIPE FROM TOWER BASIN TO TC SYSTEM IS 2-1/2" PIPE.
13. FLOODED SUCTION REQUIRED.

**COMPONENT LIST:**

- ① ELECTRICAL CONTROL BOX 208V/230V/460V, 60Hz W/120V TRANSFORMER.
- ② SEPARATOR: eHTX-0025-V.
- ③ PUMP: 2 HP CENTRIFUGAL, 3600 rpm, 208V/230V/460V, 60Hz.
- ④ INLET/OUTLET PRESSURE GAUGES: 0-160 psi, GLYCERIN-FILLED.
- ⑤ PURGE EQUIPMENT: SRV-833.
- ⑥ STRAINER, SUCTION DIFFUSER.

**SUBMITTAL DRAWING**

This drawing is submitted for spatial consideration only. Do not pre-plumb to these dimensions.

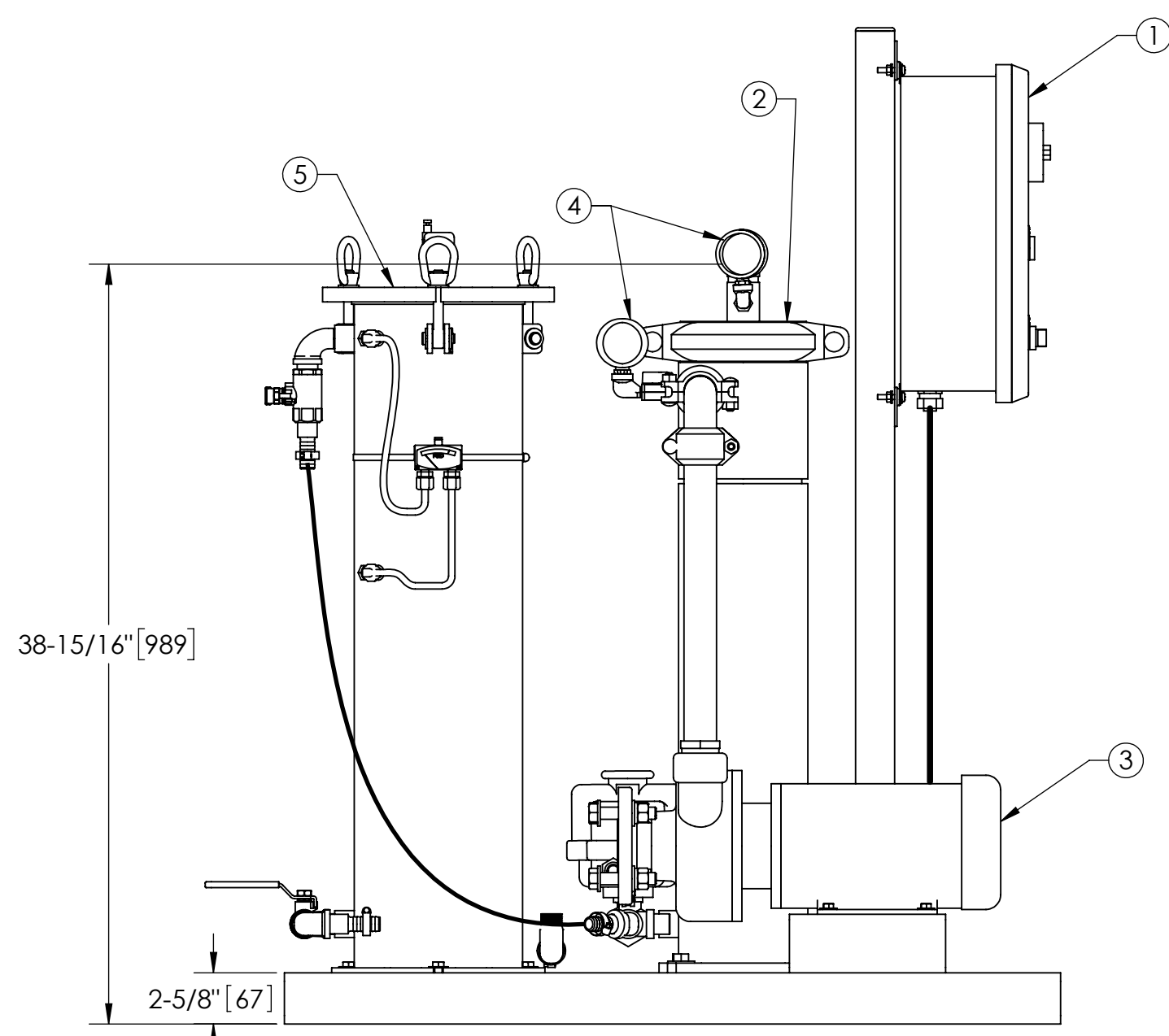

**FRONT VIEW W/O STRAINER**

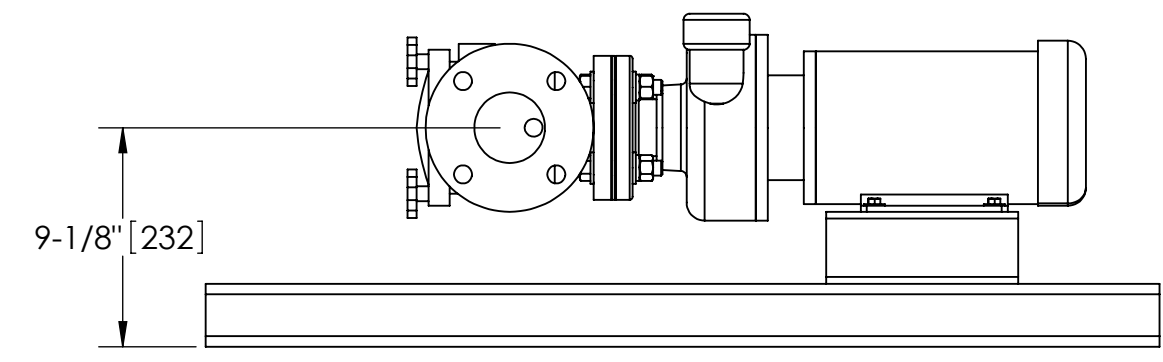

**FRONT VIEW ROTATED STRAINER (STRAINER)**

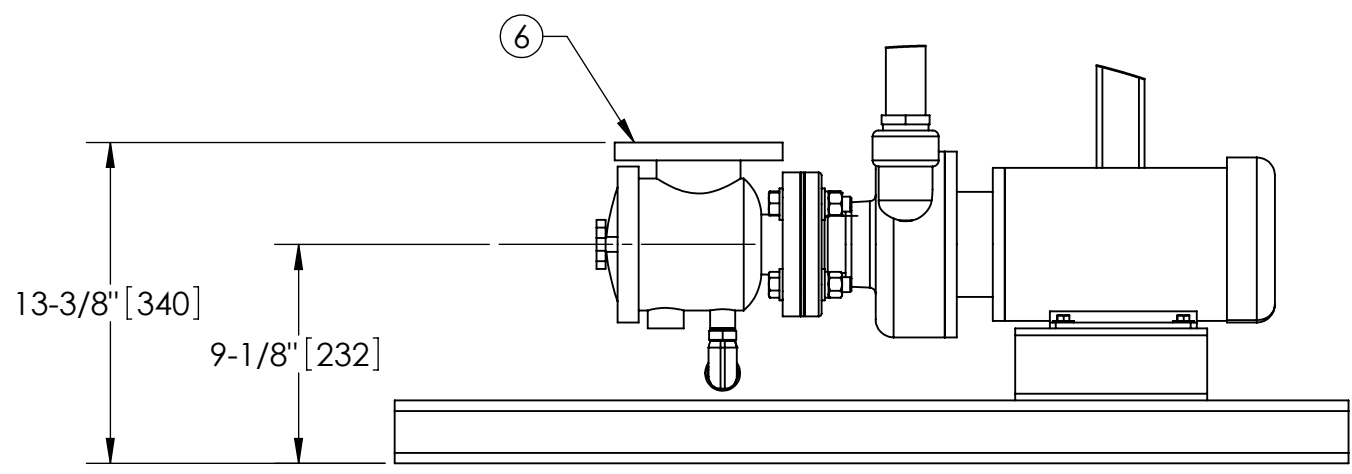

**FRONT VIEW PUMP & STRAINER**

<small>UNLESS OTHERWISE SPECIFIED: DIMENSIONS ARE IN: INCHES (mm) TOLERANCES ARE: FRACTIONS DECIMALS ANGLES ± 1/2" .XX ± .01 ± 1/4" .XXX ± .005 .XXXX ± .0005</small>	ENGINEERED FOR:			<small>CLAUDE LAVAL CORP. FRESNO, CALIFORNIA 93727 WWW.LAKOS.COM</small>		
	STANDARD			TITLE	eTCX-0050-SRV/EFS/ACP1 TC SYSTEM	
	APPROVALS	DATE		HI EFF SWEEPER eHTX-0025 3/60/208V-230-460V		
	DRAWN	ADJ		12/10/20	SIZE	MODEL NO.
DO NOT SCALE DRAWING	ENGR	-	SCALE	1:8		
MATERIAL	PER LAKOS SPEC	MFG	WORK ORDER	QTY.	DWG NO.	
FINISH	AS ASSEMBLED				184834	
					REV. A	
					EST. WT. 535 lb	
					SHEET 1 OF 1	

DWG NO. 184834  
 SHEET A  
 REV. A