

EXCEPT AS OTHERWISE PROVIDED BY CONTRACT, THIS DRAWING AND SPECIFICATIONS SHALL NOT BE REPRODUCED, COPIED OR USED AS THE BASIS FOR MANUFACTURE OR SALE OF MATTER DEPICTED HEREIN WITHOUT THE EXPRESSED WRITTEN PERMISSION OF THE CLAUDE LAVAL CORPORATION, OR ITS ASSIGNEES.

REVISION HISTORY				
ZONE	REV	DESCRIPTION	DATE	APPROVED

THIS DRAWING HAS BEEN GENERATED AND IS MAINTAINED BY A CAD SYSTEM. CHANGES SHALL ONLY BE INCORPORATED AS DIRECTED BY AN APPROVED ENGINEERING CHANGE ORDER (ECO). PAPER COPIES ARE UNCONTROLLED.

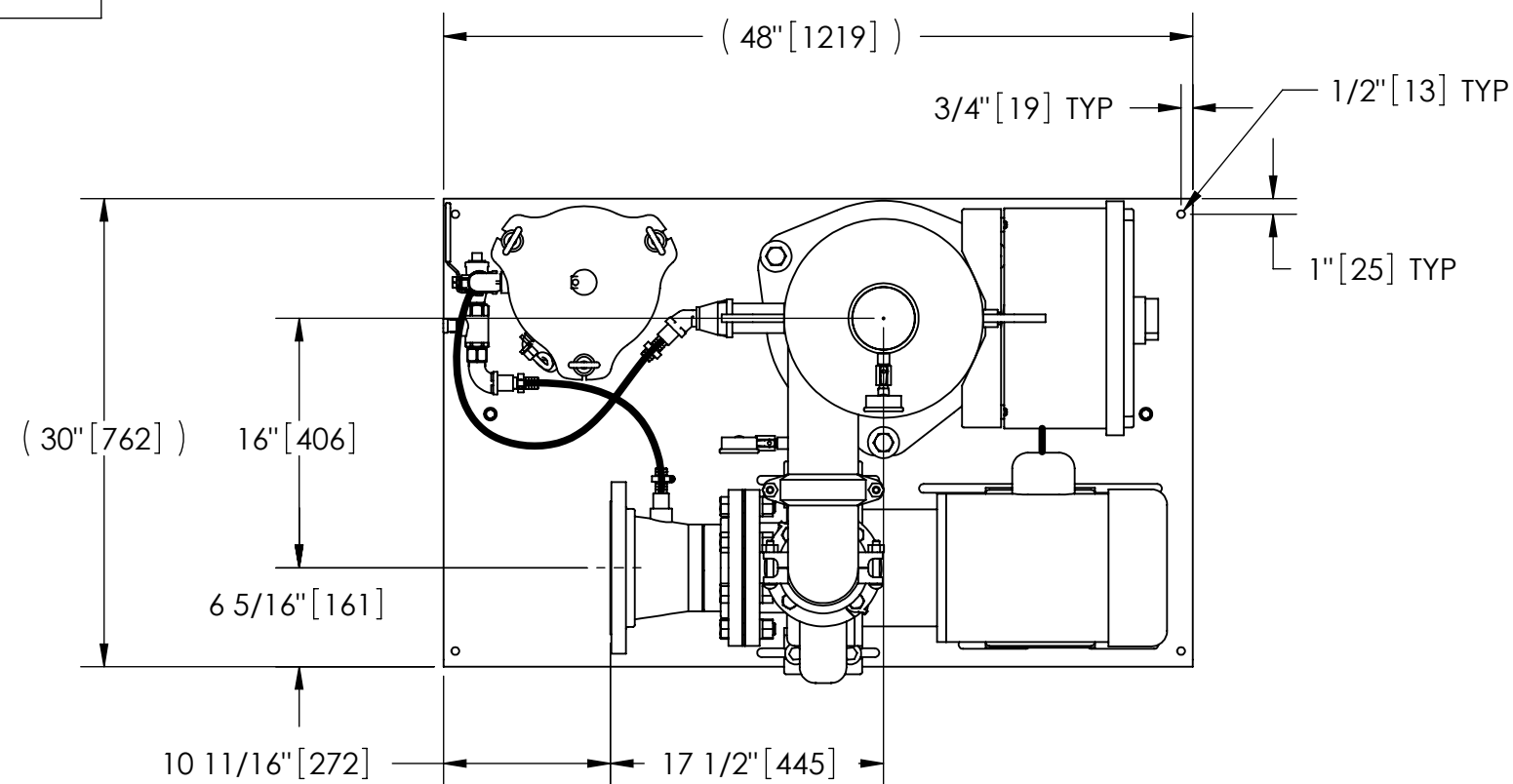

TOP VIEW

NOTES:

- INLET IS 6" PIPE (150# ANSI FLANGED).
- OUTLET IS 4" PIPE (GROOVED).
- PURGE OUTLET IS 1-1/2" PIPE.
- MAXIMUM PRESSURE: 150 psi (10.3 bar).
- MAXIMUM TEMPERATURE: 100°F (37.8°C).
- SPECIFIED FLOWRATE OF 400 gpm (91 m³/hr).
- FINISH: AS ASSEMBLED.
- POWER REQUIREMENT: 460V, 3PH, 60Hz.
- NEMA 4X MOTOR STARTER ENCLOSURE WITH SAFETY DISCONNECT AND H.O.A. SWITCH.
- APPROXIMATE DRY WEIGHT: 965 lbs (437 kg).
- INLET/OUTLET VALVE KIT, MODEL TCV-0400 RECOMMENDED.
- MINIMUM PIPE TO TB SYSTEM IS 6" PIPE.
- FLOODED SUCTION REQUIRED.

COMPONENT LIST:

- ELECTRICAL CONTROL BOX 460V 60Hz W/120V TRANSFORMER.
- SEPARATOR: HTH-0285-TC.
- PUMP: 7.5 HP CENTRIFUGAL, 1750 rpm, 460V, 60Hz.
- INLET/OUTLET PRESSURE GAUGES: 0-100 psi, GLYCERIN-FILLED.
- PURGE EQUIPMENT: SRV-816.
- DIFFERENTIAL PRESSURE INDICATOR: (AVAILABLE WITH DRY CONTACT-MODEL DHE-15-S. ORDER SEPARATELY).

SUBMITTAL DRAWING

This drawing is submitted for spatial consideration only. Do not pre-plumb to these dimensions.

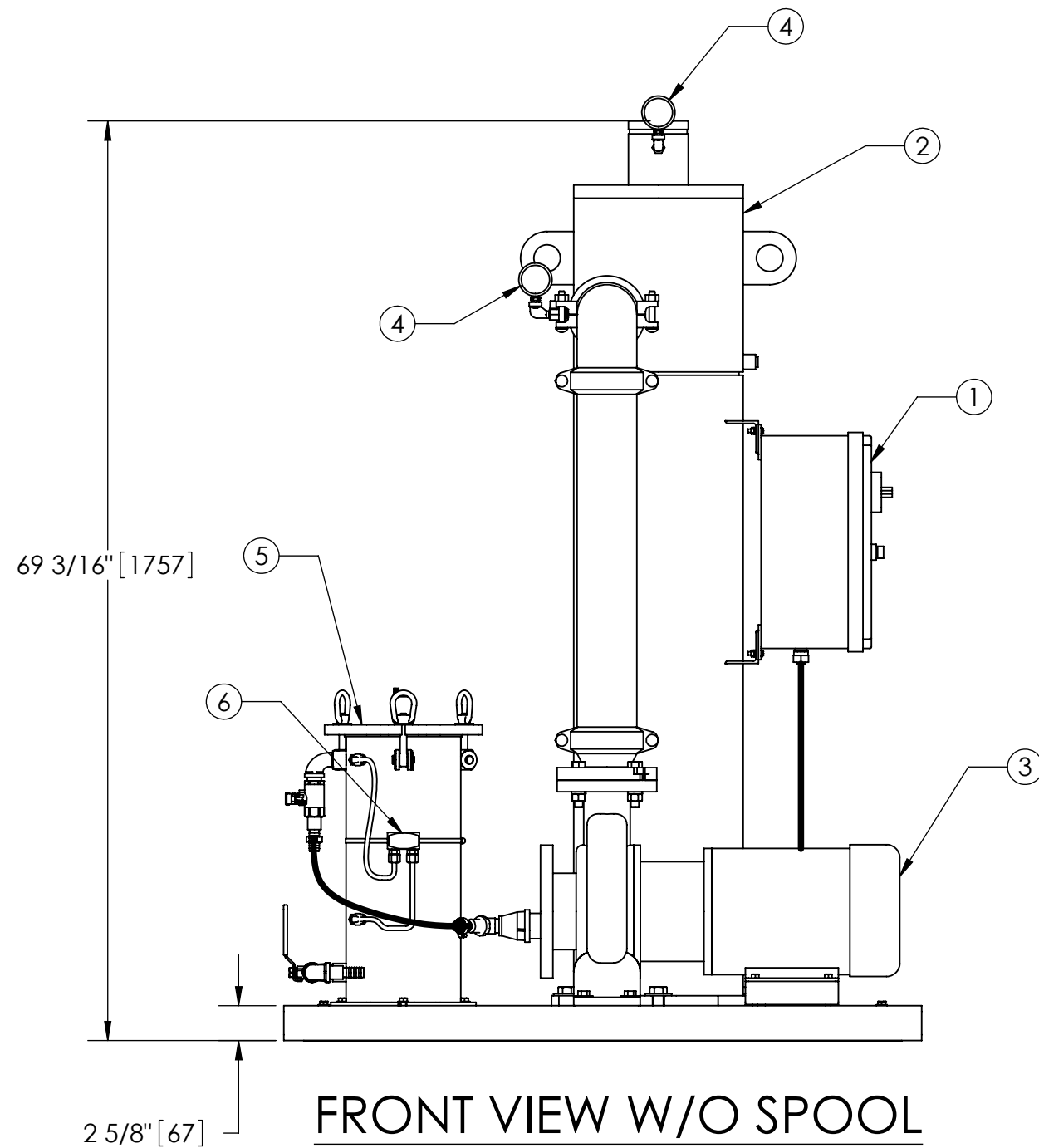

FRONT VIEW W/O SPOOL

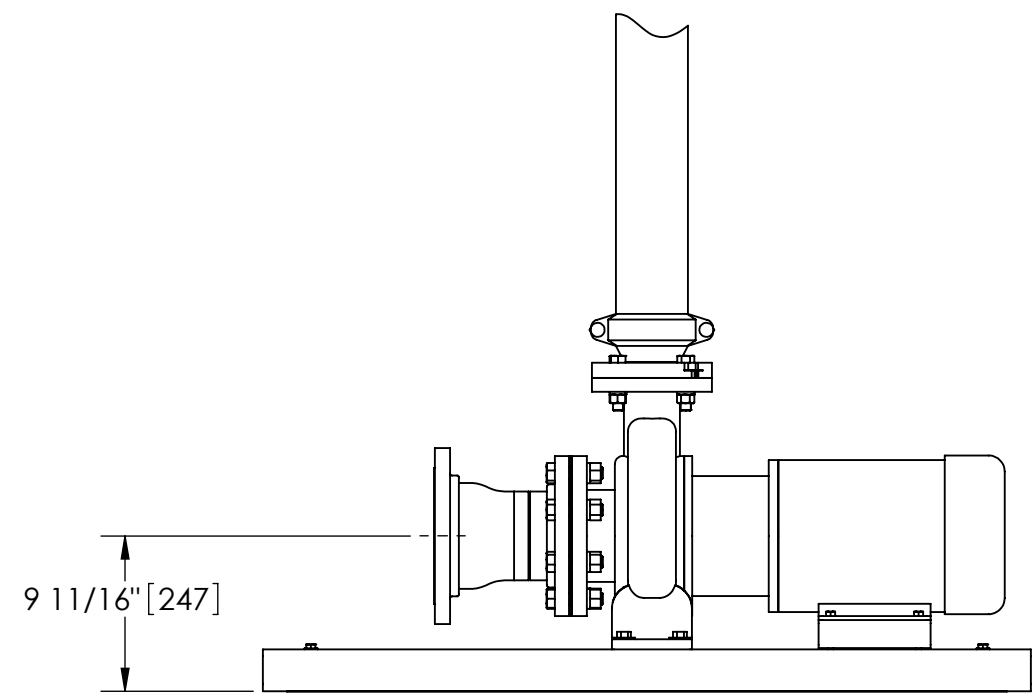

FRONT VIEW PUMP AND SPOOL

UNLESS OTHERWISE SPECIFIED: DIMENSIONS ARE IN: INCHES (mm) TOLERANCES ARE: FRACTIONS DECIMALS ANGLES ± 1/2" .XX ± .01 ± 1/4" .XXX ± .005 .XXXX ± .0005	ENGINEERED FOR: STANDARD		CLAUDE LAVAL CORP. FRESNO, CALIFORNIA 93727 WWW.LAKOS.COM	LAVAL UNDERGROUND SURVEYS
	APPROVALS	DATE		
DO NOT SCALE DRAWING	DRAWN GMB	5/16/05	TITLE TBI-0400-SRV, TC SYSTEM, SIDESTREAM HTH-0285, 460V 60HZ STD	
MATERIAL PER LAKOS SPEC	ENGR HSK	9/12/05	SIZE C	MODEL NO.
FINISH AS ASSEMBLED	MFG -	-	DWG NO. 115457	REV. A
	WORK ORDER	QTY.	SCALE 1:12	EST. WT. 965 lb
			SHEET 1 OF 1	

DWG. NO. 115457 SHEET 1 REV. A