



# Auto Purge with Pneumatic Pinch Valve

## APP Series

### High performance purging systems for handling tough solids/liquids applications.

This durable, dependable purging system combines the versatility and timing accuracy of the LAKOS controller with a specially matched air-operated pinch valve to eliminate the manual routine maintenance of purging LAKOS Separators.

- Straight-through valve design and unique liner assembly allow this system to effectively purge most solids/liquids.
- Especially well suited for heavy solids (specific gravities greater than 3.6), fibrous materials, most larger solids and medium solids loads.
- Standard natural rubber liner resists heavy abrasives and corrosives, including 10% hydrochloric acid, 10% sulfuric acid, salts, caustics and temperatures up to 180°F (82°C). For even tougher applications, liners are available in neoprene, butyl, buna N and hypalon.

Included in this system is an air pressure regulator which helps preserve the life of the valve liner by feeding only as much pressure as needed for effective closure of the valve. Also included is an appropriate manual isolation valve.

### Controller

- Fully unattended automatic operation
- Serves worldwide single-phase voltages, from 100 to 240 VAC, 50/60Hz (5 amp max.) Consult factory for additional voltage options
- Wide range of options for programming purge cycle frequency and duration
- Solid state reliability; no routine maintenance required
- Durable NEMA-4x rated housing; IP 66 equivalent
- Compression molded, fiberglass reinforced polyester housing
- Meets CSA, UL, and CE requirements
- Non-volatile memory - all controller settings are maintained in the event of a loss of power; no programming required

### SUGGESTED INSTALLATION

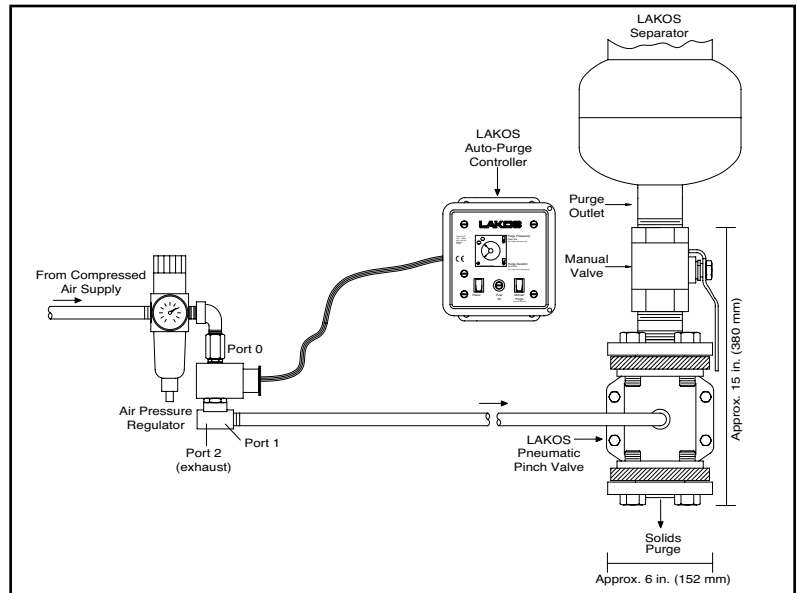

### ILLUSTRATION OF CONTROLLER FACE

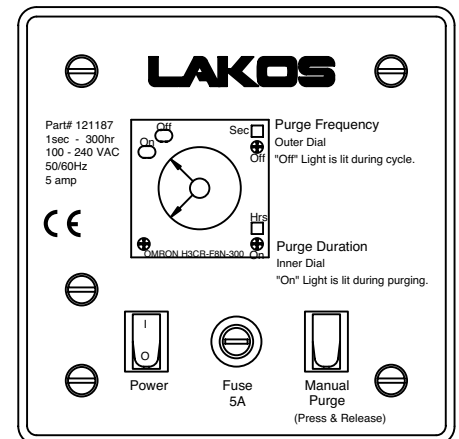

### WIRING DIAGRAM

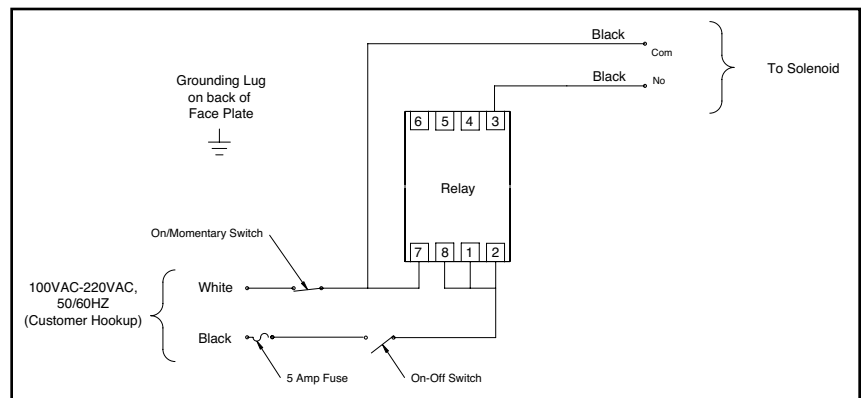

See reverse for additional specifications

# Pneumatic Valves and Solenoid

## Operation

The LAKOS Pneumatic Pinch Valve is controlled with a supply of air passing through the solenoid. This air supply must exceed the LAKOS Separator's inlet pressure by 30 psi (2.1 bar). Consequently, the maximum inlet pressure to the LAKOS Separator cannot exceed 95 psi (6.6 bar) because the pinch valve has a maximum working pressure of 125 psi (8.6 bar). Consult factory for applicable alternatives.

To open the pinch valve for purging the Separator, the LAKOS controller energizes the solenoid, thereby shutting off the air supply to the valve. Pressure to the valve then escapes through the bleed opening of the solenoid (normally closed when not purging), allowing the pinch valve to open for purging. After purging for the programmed duration, the controller de-energizes the solenoid, allowing it to open and deliver air to the pinch valve. This air pressure then closes the pinch valve's liner and stops the purging process.

## Solenoid Installation

The solenoid controls the air supply to the valve and is activated by the LAKOS controller. Install air supply lines to the proper ports, as noted in the illustration on reverse.

Valve Model	Line Size NPT, female	Valve Weight		Maximum Working Pressure	
		lbs.	kg	psi	bar
APP-10	1 inch	15	6.8	125	8.6
APP-15	1-1/2 inch	17	7.7	125	8.6
APP-20	2 inch	32	14.5	125	8.6
APP-30	3 inch	55	24.9	125	8.6

## Liquid Loss

When the application allows that purging is the final handling of the separated solids, it may be important to know the volume of fluid which may be lost when purging. This information is subject to variations, based on separator size, flow rate and system pressure. Volumes noted here identify the total volume purged (both liquid and solids).

Purge Size	4 Second Duration*	10 Second Duration
1-inch	3-12 gallons	7-25 gallons
	11-45 liters	26-95 liters
1 1/2-inch	5-20 gallons	12-50 gallons
	19-76 liters	45-190 liters
2-inch	10-35 gallons	25-95 gallons
	38-132 liters	95-360 liters
3-inch	25-90 gallons	63-225 gallons
	95-340 liters	238-850 liters

\* The 4-second purge is limited to pneumatic pinch valves or manual purging.

## Limited Warranty

All products manufactured and marketed by this Corporation are warranted to be free of defects in material or workmanship for a period of one year from date of delivery.

If a fault develops, notify us, giving a complete description of the alleged malfunction. Include the model number(s), date of delivery and operating conditions of subject product(s). We will subsequently review this information and, at our option, supply you with either servicing data or shipping instructions and returned goods authorization. Upon prepaid receipt of subject product(s) at the instructed designation, we will then either replace such product(s) at our option and, if determined to be a warranted defect, we will perform such necessary product repairs or replace such product(s) at our expense.

This limited warranty does not cover any products, damages or injuries resulting from misuse, neglect, accident, normal expected wear, improper installation or operation contrary to factory recommendations. Nor does it cover equipment that has been modified, tampered with or altered without factory authorization.

No other extended liabilities are stated or implied and this warranty in no event covers incidental or consequential damages, injuries or costs resulting from any such defective product(s).

LAKOS products are protected under multiple U.S. and foreign patents and trademarks. For details contact LAKOS.



1365 N. Clovis Avenue • Fresno, California 93727 USA  
 Telephone: (559) 255-1601  
 www.lakos.com • info@lakos.com