



# Automatic Pump Safety Shut-Off Control

## Protects Your Pump and Suction Intake Screen from Damage in the Event of Excessive Screen Clogging and Vacuum Build-Up

Should large debris or unusual conditions cause restricted water flow through your pump intake screen, the LAKOS Automatic Pump Safety Shut-Off Control will monitor the suction loss and stop the operation of your pump before either the pump or screen can suffer damage that would otherwise lead to expensive repairs or replacements. And, in addition to providing you with peace of mind by protecting your equipment when you can't be there, the control unit also includes an easy-to-read indicator gauge that informs you at a glance of any operating suction loss when you are on-site.

The water column vacuum (suction) gauge reads the vacuum at the screen outlet. Registering from 0-30 column inches (0-76 cm) of water, it is factory set to interrupt the pump's operation at 5-inches (13 cm). **NOTE:** If you already have a "mercury gauge," the LAKOS Shut-Off Control is far more sensitive to operating conditions, providing more certain protection for your pump and screen. For convenient viewing, the gauge can be mounted on the control panel of your pump's power source...gas engine, electric motor or diesel engine...or on an adjacent stand.

Your pump and intake screen represent an important investment. Protect that investment with a sensible, economical and trouble-free LAKOS Automatic Pump Safety Shut-Off Control.

## Specifications

**Rating:** 2 Amps @ 30 VAC/DC

**Control Connecting Wire:** 18 gauge, 12-inches long

**Case:** Steel

**Face Covering:** Clear polycarbonate

**Calibration:** ±2 - inches of water across the scale

**Note:** Additional specifications are packaged with the control unit

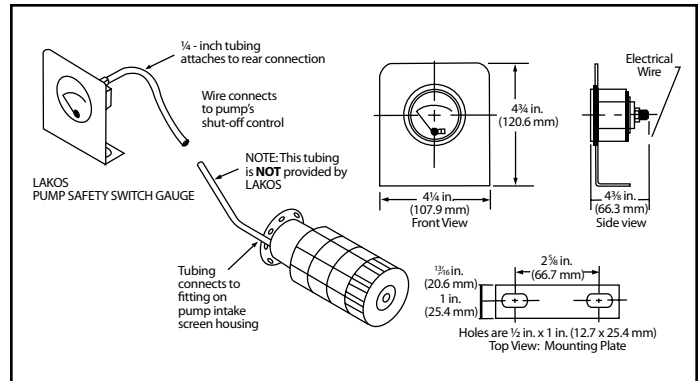

## Installation Instructions

- 1 Attach the switch gauge connecting wire (extending out of the back of the gauge) to the power shut-down controls of your pump's 12 volt DC engine. (NOTE: For high voltage electric pump motors, a variable input relay must be used.)
- 2 Remove the red safety cap from the threaded connector on the back of the gauge. Attach the necessary length of 1/4-inch I.D., flexible tubing (not provided) to the brass fitting at one end and to the 1/4-inch hose barb fitting on your intake screen's flanged outlet at the other. (NOTE: If your screen is an older model without this fitting, drill a 3/8-inch hole and tap with a 1/8-inch pipe tap.)
- 3 Mount the gauge either to the control panel of your pump's power source or to an adjacent stand. (Due to vibration, the stand is the preferable choice.) Be certain to use the shock mounts, nuts and washers provided with your gauge. Failure to do so could result in severe vibration and serious damage or destruction of your Safety Shut-Off Control.

**NOTE:** The adjustable contact point located on the face of the indicator will arrive set at a recommended 5-inches of water column vacuum. If you must readjust, use a 1/16-inch hex allen wrench.

Lakos Separators are manufactured and sold under one or more of the following U.S. Patents: 5,320,747; 5,338,341; 5,368,735; 5,425,876; 5,571,416; 5,578,203; 5,622,545; 5,653,874; 5,894,995; 6,090,276; 6,143,175; 6,167,960; 6,202,543; 7,000,782; 7,032,760 and corresponding foreign patents, other U.S. and foreign patents pending.

**LAKOS**  
Separators and Filtration Solutions®

A wholly owned subsidiary of Lindsay Corporation

1365 N. Clovis Avenue • Fresno, California 93727 USA

Telephone: (559) 255-1601 • Fax: (559) 255-8093

www.lakos.com • info@lakos.com