

Groundwater Sand Separators - LGS

Easily Remove Sand, Dirt, and Silt From Groundwater



Pressure gauges not included

Remove 99% of Sand and Silt

Flow Range
225 - 2,450 GPM

Maximum Standard Pressure Rating
150 PSI

Maximum Temperature
180° F (82.2° C)

Pressure Loss
As Low as 3 psid

LGS Features and Benefits:

- **Industry First - Independently Tested:** Only LAKOS LGS Separators are independently tested by a 3rd party for filtration performance. See page 4 for details.
- **Premium Filtration:** LGS Separators are uniquely engineered to remove settleable solids commonly found in Groundwater; LGS models remove 99% of solids down to 74 microns at 2.6 SG.
- **No Maintenance Filtration:** LGS Separators use centrifugal action to remove sand, dirt, and silt from groundwater. There are no screens, moving parts, discs, or fill media to replace or maintain.
- **No Backwashing:** LAKOS LGS Centrifugal Separators do not require backwashing to remove captured dirt; automated periodic purging removes captured debris.
- **Low and Steady Pressure Loss:** LAKOS LGS Separators operate at a steady pressure loss; Consistent pressure loss as low as 3 psid.

Accessories



Installation Kit contains parts for easier, more professional installation.

Installation Kit



Automatic Ball Valve Kit automates separator purge cycles. Nema 4x Controller provides ability to adjust purge frequency and duration.

Automatic Ball Valve and Controller Kit

Flow Rates & Specifications

FLOW VS. PRESSURE LOSS CHART

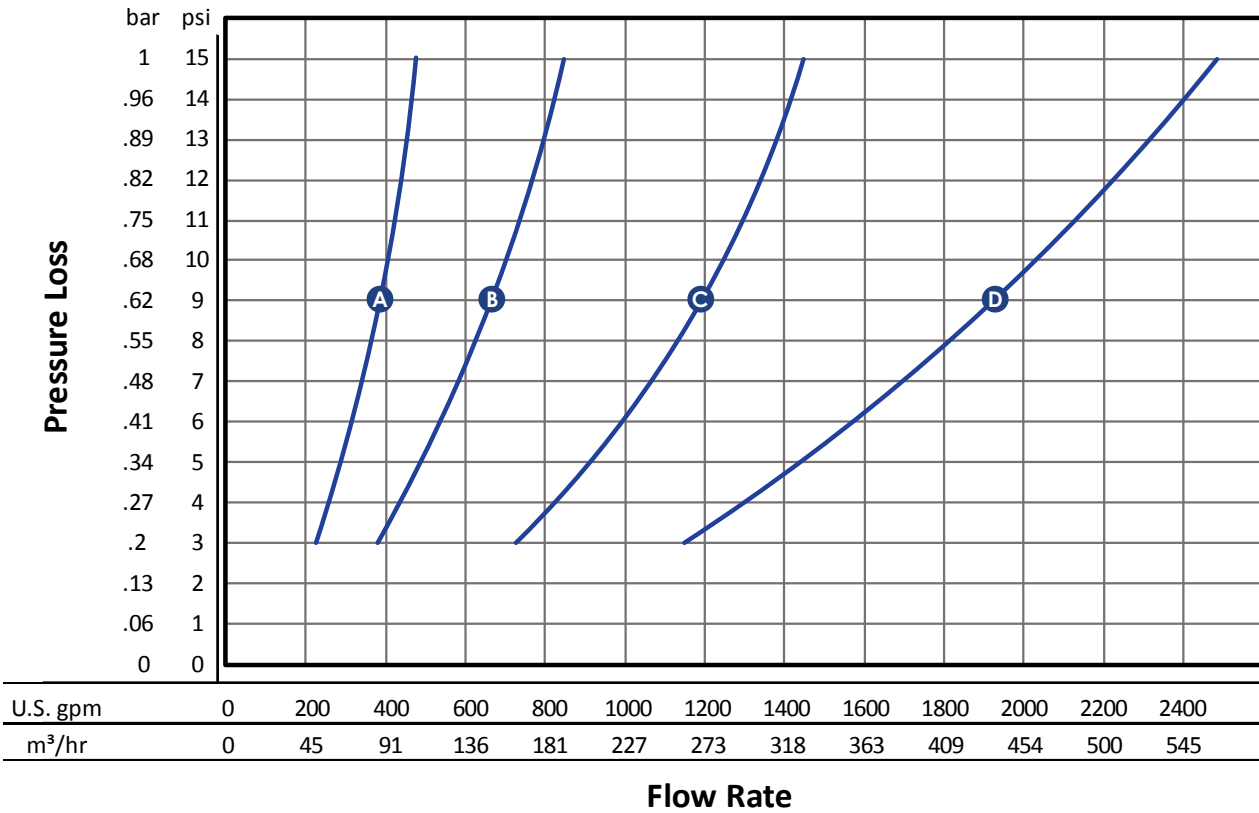

A LGS-0225-L **B** LGS-0385-L **C** LGS-0750-L **D** LGS-1150-L

SPECIFICATIONS

Model	Flow Range		Inlet/Outlet Grooved Coupling	Purge Size Male N.P.T.	Collection Chamber Capacity		Weight		Weight with Water	
	US gpm	m³/hr			gal	liters	lbs	kg	lbs	kg
LGS-0225-L	225-500	51-114	4"	1-1/2"	2	6	299	136	489	222
LGS-0385-L	385-850	88-193	6"	1-1/2"	3	11	446	202	876	397
LGS-0750-L	750-1450	170-330	8"	1-1/2"	6	23	758	344	1758	797
LGS-1150-L	1150-2450	261-556	10"	2"	15	57	1311	595	3711	1683

SEPARATOR COLLECTION CAPACITY

Model	Collection Chamber Capacity	
	gal	liters
LGS-0225-L	3	11
LGS-0385-L	5	18
LGS-0750-L	12	45
LGS-1150-L	14	59

Dimensions and Installation Instructions

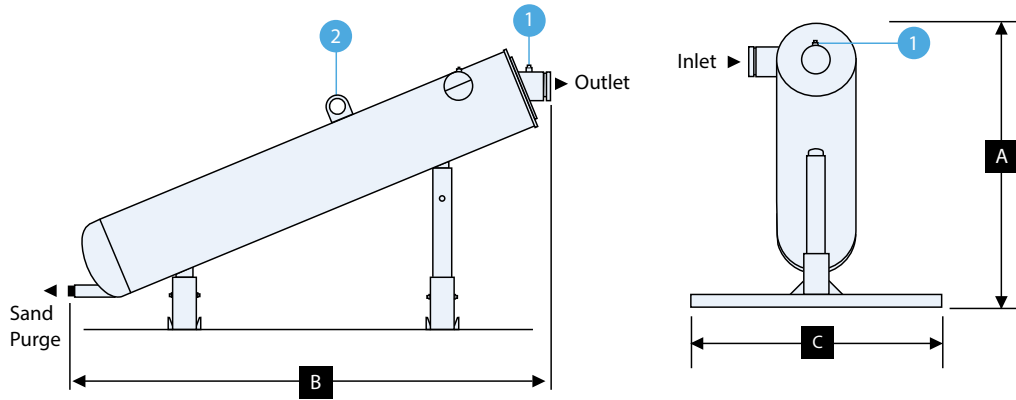

- 1 Inlet/Outlet Pressure Gauge Taps**
1/4-inch NPT female; required at both inlet and outlet for proper flow verification

- 2 Lifting Ring**
For installation purposes

DIMENSIONS

Model	A		B		C	
	in	mm	in	mm	in	mm
LGS-0225-L	39	978	69	1753	40	1016
LGS-0385-L	48	1226	86	2172	40	1016
LGS-0750-L	64	1619	115	2915	40	1016
LGS-1150-L	84	2121	153	3874	40	1016

Installation Instructions

- LAKOS LGS Separators are shipped on a wooden skid with the two support legs detached. A large ring, located on the unit's side, is provided for hoisting as necessary.
- A suitable foundation is necessary to accommodate the separator's weight including water (see chart, page 2). Tie-down bolts are recommended in the base of the legs. Prior to installation, inspect the inlet, outlet and purge of each unit for foreign objects that may have entered the unit during shipping or storage.
- Proper purge hardware is required to flush separated sand from the separator. This equipment should be installed before start-up.
- Pipe connections to the inlet and outlet of LAKOS LGS Separator should be a straight run of at least five pipe diameters to minimize turbulence and optimize performance. Pipe size is not a factor in selecting the proper model of a LAKOS Separator. Rather, all LAKOS Separators operate within a prescribed flow range.
- Use appropriate hardware to match inlet and outlet size. Grooved couplings are not included with the separator.
- The minimum inlet pressure is the expected pressure loss through the separator, plus downstream requirements. **Pressure gauges are required at both inlet and outlet to monitor pressure loss and proper system flow (Pressure gauges not included).** If the separator is operated at open discharge, a valve is recommended at the outlet, set to create a backpressure of 5 psi (0.3 bar).
- LAKOS LGS Separators must be installed on the discharge of a pumping system. No other pressure or power is required to operate a LAKOS Separator.
- Winterizing is important if the separator is to remain idle in freezing temperatures. Drain water as necessary to avoid bursting due to water-ice expansion.

Filtration Test completed on Lakos Separator – LGS-0385-L

The filter assembly was installed with test components defined as follows installed in the following order starting upstream:

- 1) 4" Venturi-type flow meter
- 2) 55 micron 4 disc filter assembly
- 3) 6" pipe spool with sand separator injection pump
- 4) Separator under test
- 5) 6" pipe spool
- 6) 6" Butterfly valve
- 7) 20 micron 4 disc filter assembly

Test Conditions: 495 gpm

Test Sample Breakdown (Grams)

Sample size: 250 grams

Recovered grams from downstream filters: 2.7g

Filter efficiency: $246.18 / 250 = 98.20\%$

Note: Media: Quartz, Silica Dioxide, specific gravity: 2.6

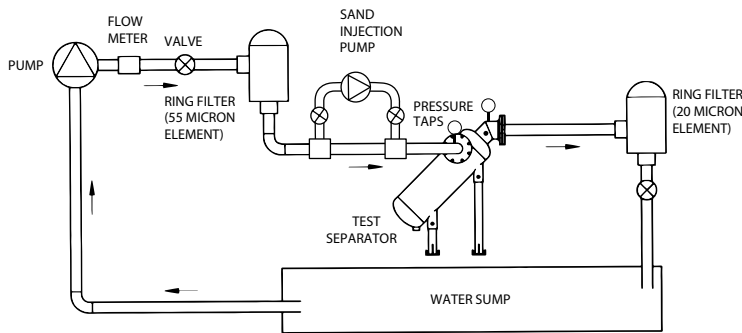

LAKOS Separators have been independently tested and certified by an independent testing agency, the International Center for Water Technology (ICWT), confirming our separators' filtration performance and capability to remove troublesome particle matter from pumped water.

For over 30 years the internationally recognized ICWT/CIT Testing Laboratories have been providing independent, third party testing to a wide range of irrigation and other industries around the world.

ICWT has experience with hydraulics, pumps, filters, and valves. ICWT was recently certified by IAPMO R&T - North America's premier third party certification body for plumbing and mechanical products. More information about the testing agency and testing process can be found at www.californiawater.org.

This test agency is available and approachable to confirm its test methodologies and results.

International Center for Water Technology-
California State University Fresno
5370 North Chestnut Ave., Fresno, CA 93740-0018,
Phone: 559-278-2066, www.californiawater.org



LAKOS, headquartered in Fresno California since 1972, is recognized worldwide for engineering, manufacturing and marketing the original centrifugal action solids from liquids separator and being the world-wide leader in cyclonic separation technology.

LAKOS Separators are manufactured in the USA.

All LAKOS LGS Separators are warranted for five (5) years from date of delivery. For detailed warranty information visit <http://www.lakos.com>

LAKOS Separators are manufactured and sold under one or more of the following U.S. Patents: 5,320,747; 5,338,341; 5,368,735; 5,425,876; 5,578,203; 5,622,545; 5,653,874; 5,894,995; 6,090,276; 6,143,175; 6,167,960; 6,202,543; 7,000,782; 7,032,760 and corresponding foreign patents, other U.S. and foreign patents pending.

LS-1055B (Rev. 9/20)