

EXCEPT AS OTHERWISE PROVIDED BY CONTRACT, THIS DRAWING AND SPECIFICATIONS SHALL NOT BE REPRODUCED, COPIED OR USED AS THE BASIS FOR MANUFACTURE OR SALE OF MATTER DEPICTED HEREIN WITHOUT THE EXPRESSED WRITTEN PERMISSION OF THE LAKOS CORPORATION, OR ITS ASSIGNEES.

THIS DRAWING HAS BEEN GENERATED AND IS MAINTAINED BY A CAD SYSTEM. CHANGES SHALL ONLY BE INCORPORATED AS DIRECTED BY AN APPROVED ENGINEERING CHANGE ORDER (ECO). PAPER COPIES ARE UNCONTROLLED.

REVISION HISTORY				
ZONE	REV	DESCRIPTION	DATE	APPROVED
	A	RELEASE SUBMITTAL	12/27/20	ADJ

NOTES:

1. INLET IS 2-1/2" PIPE (125# ANSI FLANGED).
2. OUTLET IS 1-1/2" PIPE (GROOVED).
3. PURGE OUTLET IS 3/4" PIPE.
4. MAXIMUM PRESSURE: 150 psi (10.3 bar).
5. MAX FLUID OPERATING TEMPERATURE: 100°F (37.8°C).
MAX AIR OPERATING TEMPERATURE: 100°F (37.8°C).
6. SPECIFIED FLOW RATES:
BASIN SWEEPING- 80 gpm (18 m³/hr).
SIDE STREAM & CLOSED LOOP- 95 gpm (22 m³/hr).
7. FINISH: AS ASSEMBLED.
8. POWER REQUIREMENT: 208V/230V/460V, 3PH, 60Hz. (CUSTOMER SPECIFIED)
9. NEMA 4X MOTOR STARTER ENCLOSURE WITH SAFETY DISCONNECT AND H.O.A. SWITCH.
10. APPROXIMATE DRY WEIGHT: 728 lbs (328 kg).
11. INLET/OUTLET VALVE KIT RECOMMENDED: SEE FACTORY.
12. MINIMUM PIPE FROM TOWER BASIN TO TC SYSTEM IS 2-1/2" PIPE.
13. FLOODED SUCTION REQUIRED.

COMPONENT LIST:

- ① ELECTRICAL CONTROL BOX 208V/230V/460V, 60Hz W/120V TRANSFORMER.
- ② SEPARATOR: eHTX-0040-V.
- ③ PUMP: 3 HP CENTRIFUGAL, 3600 rpm, 208V/230V/460V, 60Hz.
- ④ INLET/OUTLET PRESSURE GAUGES: 160 psi, GLYCERIN-FILLED.
- ⑤ PURGE EQUIPMENT: SRV-833.
- ⑥ STRAINER, SUCTION DIFFUSER.

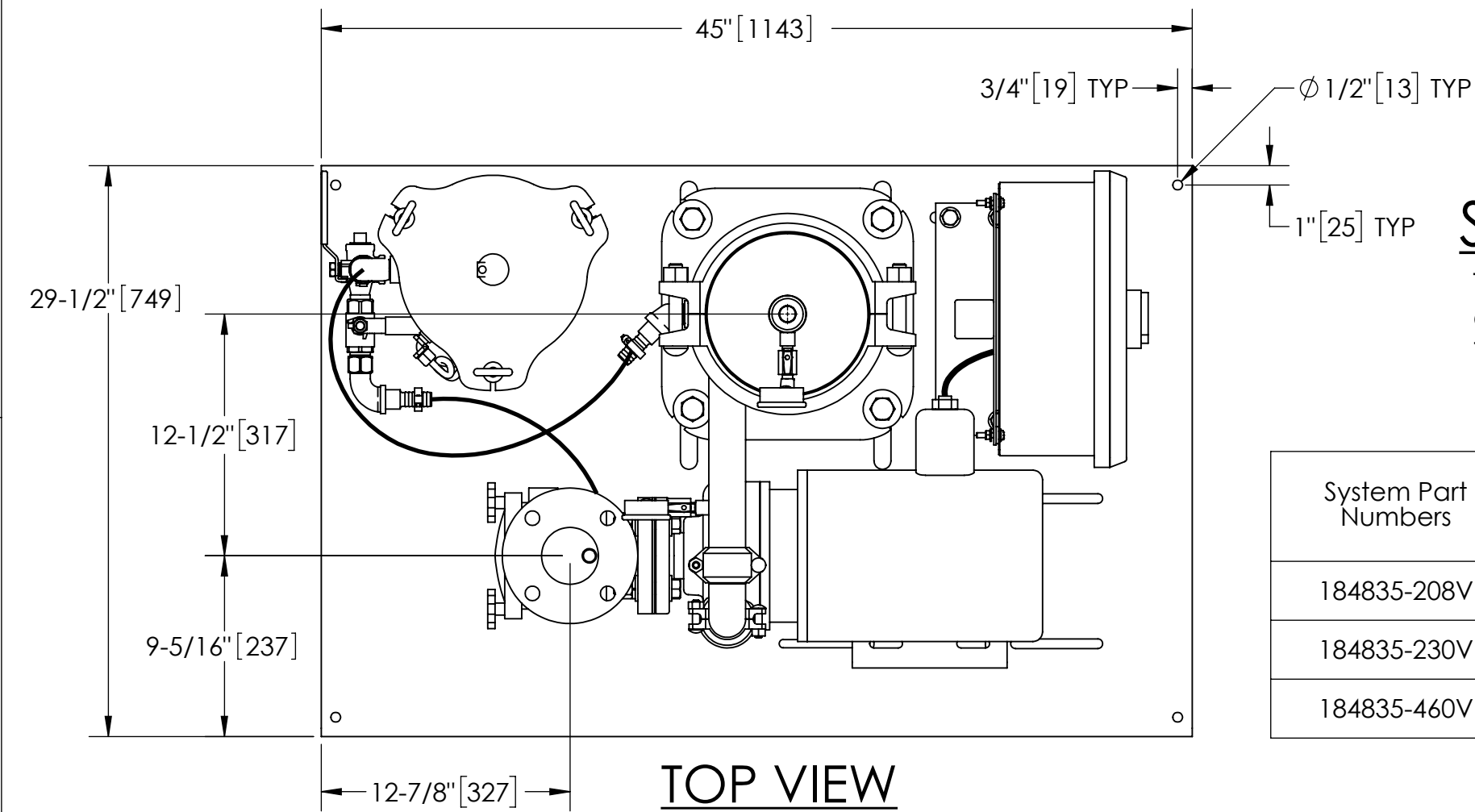

SUBMITTAL DRAWING

This drawing is submitted for spatial consideration only. Do not pre-plumb to these dimensions.

System Part Numbers	Electrical Box	Power Requirements
184835-208V	184628	3/60/208V
184835-230V	184632	3/60/230V
184835-460V	184635	3/60/460V

TOP VIEW

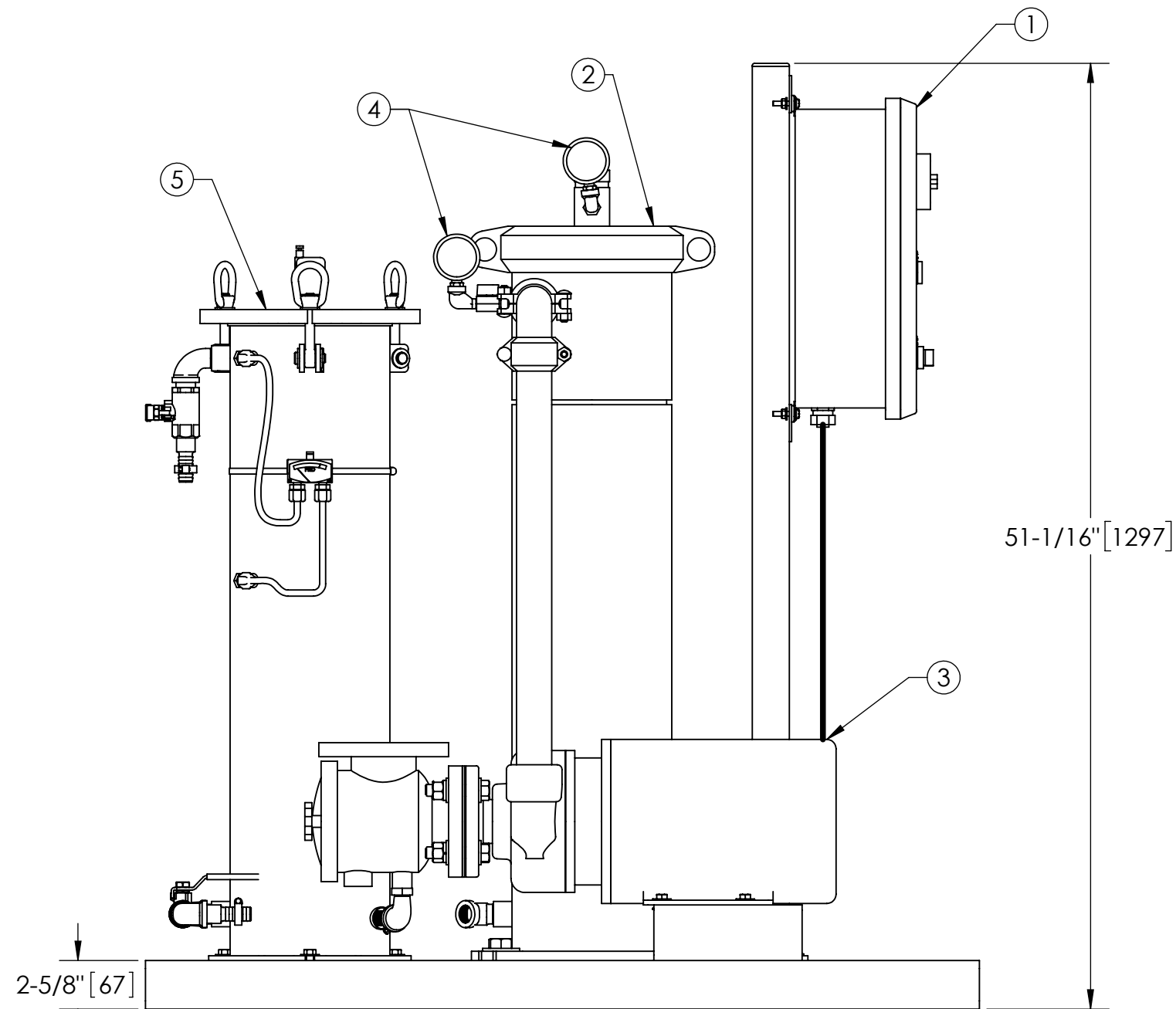

FRONT VIEW W/O STRAINER

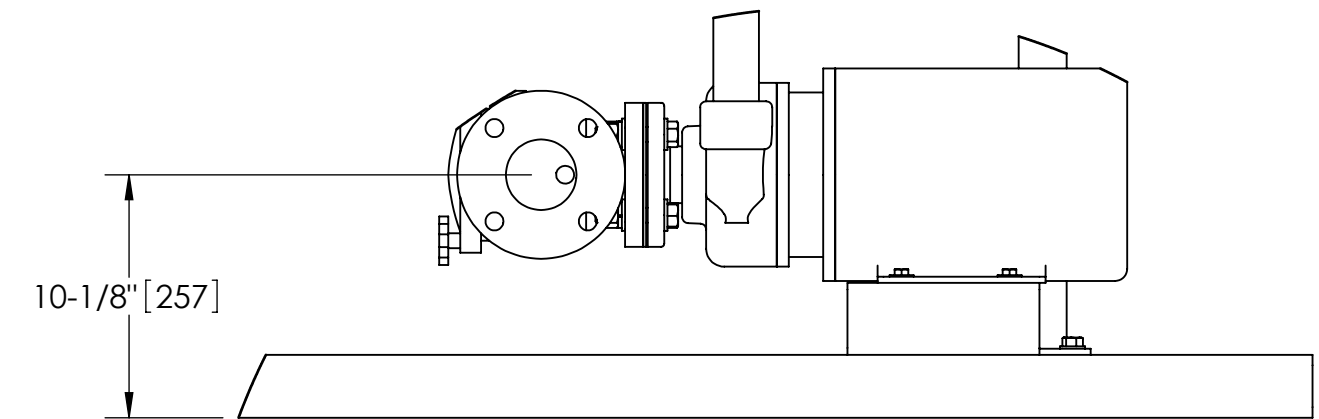

FRONT VIEW ROTATED STRAINER

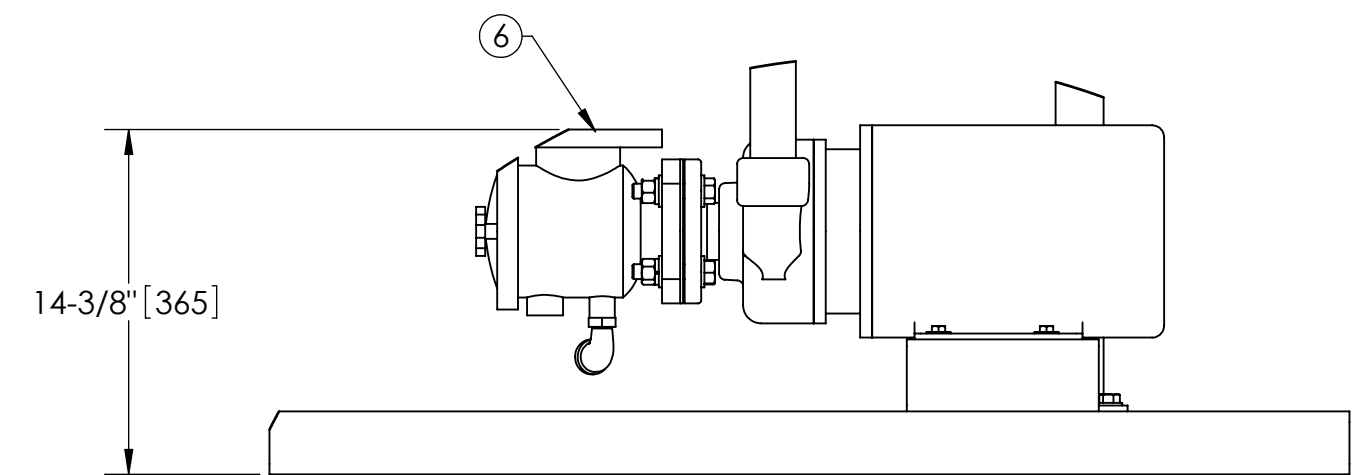

FRONT VIEW PUMP & STRAINER

<small>UNLESS OTHERWISE SPECIFIED: DIMENSIONS ARE IN: INCHES (mm) TOLERANCES ARE: FRACTIONS .XX ± .01 ANGLES ± 1/4° ± 1" .XXX ± .005 .XXXX ± .0005</small>	ENGINEERED FOR: STANDARD					
	APPROVALS	DATE				
	DO NOT SCALE DRAWING	DRAWN ADJ	12/27/20	TITLE eTCX-0080-SRV/ACP1 TC SYSTEM HI EFF SWEEPER eHTX-0040 3/60/208 230 460V		
	MATERIAL PER LAKOS SPEC	ENGR -	-			
FINISH AS ASSEMBLED	MFG -	-	SIZE C	MODEL NO.	DWG NO. 184835	REV. A
	WORK ORDER	QTY.	SCALE 1:8	EST. WT. 728 lb	SHEET 1 OF 1	

DWG NO. 184835
 SHEET A
 REV. A