

EXCEPT AS OTHERWISE PROVIDED BY CONTRACT, THIS DRAWING AND SPECIFICATIONS SHALL NOT BE REPRODUCED, COPIED OR USED AS THE BASIS FOR MANUFACTURE OR SALE OF MATTER DEPICTED HEREIN WITHOUT THE EXPRESSED WRITTEN PERMISSION OF THE CLAUDE LAVAL CORPORATION, OR ITS ASSIGNEES.

THIS DRAWING HAS BEEN GENERATED AND IS MAINTAINED BY A CAD SYSTEM. CHANGES SHALL ONLY BE INCORPORATED AS DIRECTED BY AN APPROVED ENGINEERING CHANGE ORDER (ECO). PAPER COPIES ARE UNCONTROLLED.

REVISION HISTORY				
ZONE	REV	DESCRIPTION	DATE	APPROVED

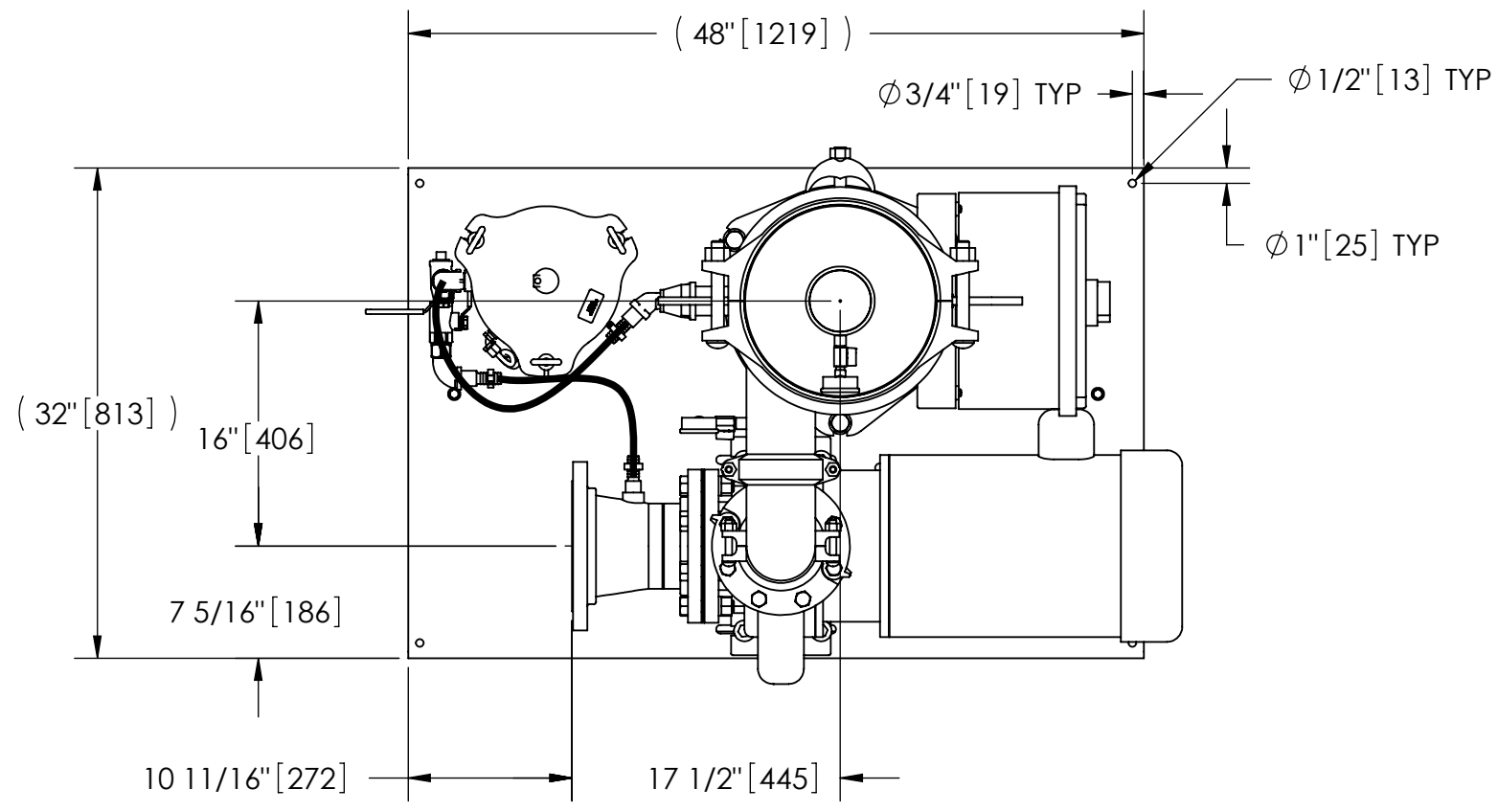

TOP VIEW

NOTES:

- INLET IS 6" PIPE (125# ANSI FLANGED).
- OUTLET IS 4" PIPE (GROOVED).
- PURGE OUTLET IS 1-1/2" PIPE.
- MAXIMUM PRESSURE: 150 psi (10.3 bar).
- MAXIMUM TEMPERATURE: 100°F (37.8°C).
- SPECIFIED FLOWRATE OF 525 gpm (119 m³/hr).
- FINISH: AS ASSEMBLED.
- POWER REQUIREMENT: 460V, 3PH, 60Hz.
- NEMA 4X MOTOR STARTER ENCLOSURE WITH SAFETY DISCONNECT AND H.O.A. SWITCH.
- APPROXIMATE DRY WEIGHT: 1088 lbs (494 kg).
- INLET/OUTLET VALVE KIT, MODEL TCV-0525 RECOMMENDED.
- MINIMUM PIPE FROM TOWER BASIN TO TC SYSTEM IS 8" PIPE.
- FLOODED SUCTION REQUIRED.

COMPONENT LIST:

- ELECTRICAL CONTROL BOX 460V 60Hz W/120V TRANSFORMER.
- SEPARATOR: HTX-0285-TC.
- PUMP: 15 HP CENTRIFUGAL, 1750 rpm, 460V, 60Hz.
- INLET/OUTLET PRESSURE GAUGES: 0-100 psi, GLYCERIN-FILLED.
- PURGE EQUIPMENT: SRV-816.
- DIFFERENTIAL PRESSURE INDICATOR: (AVAILABLE WITH DRY CONTACT-MODEL DHE-15-S. ORDER SEPARATELY).

SUBMITTAL DRAWING

This drawing is submitted for spatial consideration only. Do not pre-plumb to these dimensions.

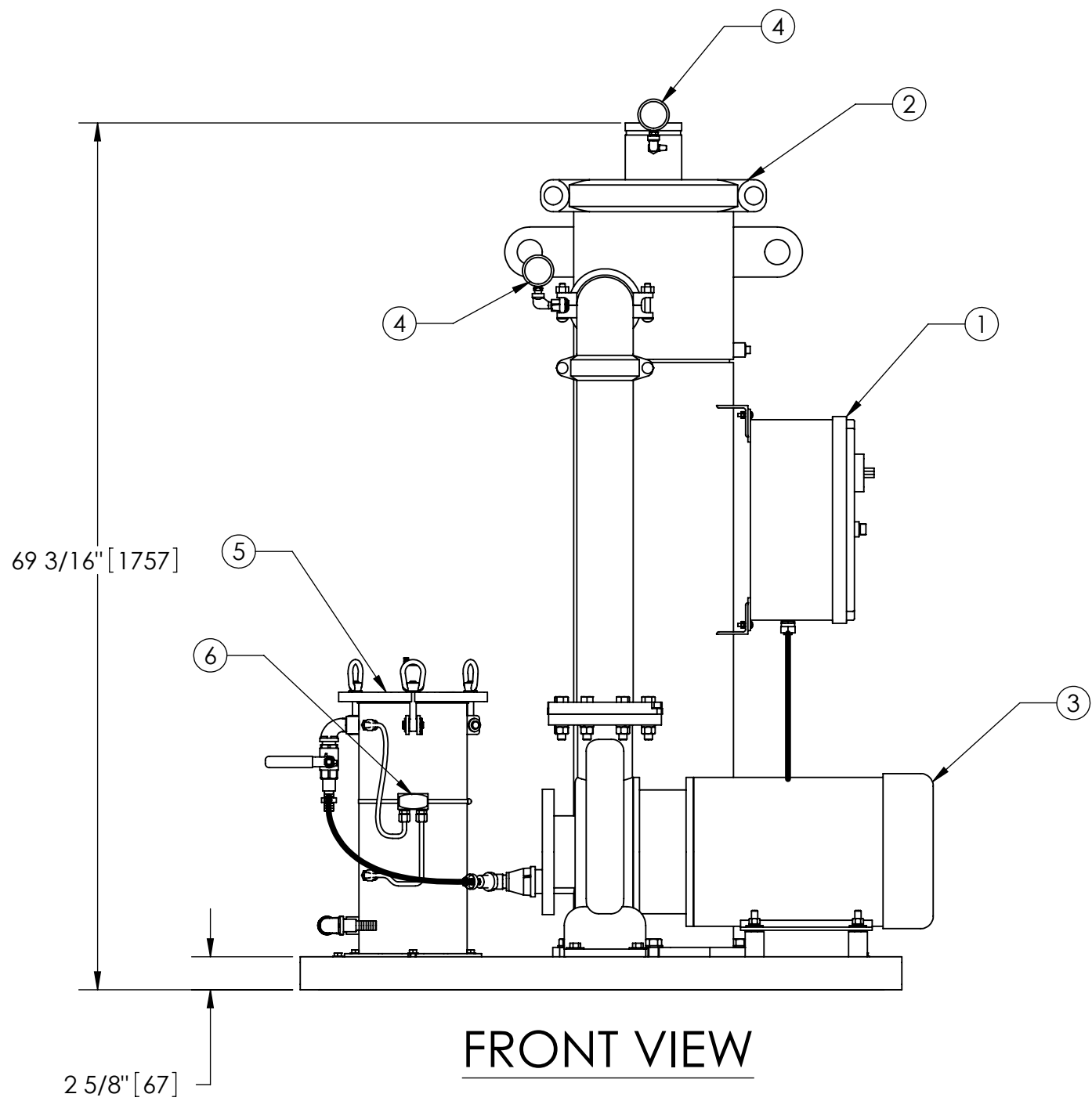

FRONT VIEW

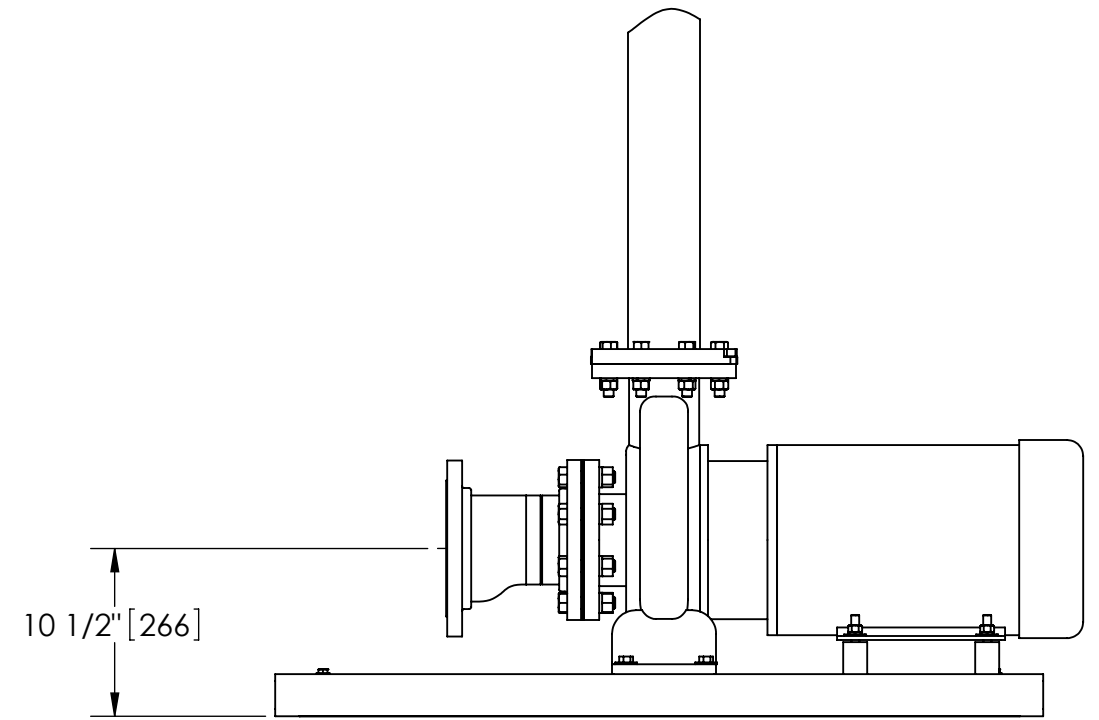

FRONT VIEW PUMP & SPOOL

UNLESS OTHERWISE SPECIFIED: DIMENSIONS ARE IN: INCHES (mm) TOLERANCES ARE: FRACTIONS DECIMALS ANGLES ± 1/2" .XX ± .01 ± 1/4" .XXX ± .005 .XXXX ± .0005	ENGINEERED FOR: <b>STANDARD</b>		CLAUDE LAVAL CORP. FRESNO, CALIFORNIA 93727 WWW.LAKOS.COM	LAVAL UNDERGROUND SURVEYS			
	APPROVALS	DATE					
DO NOT SCALE DRAWING	DRAWN	SDF/ADJ	5/23/05	TITLE <b>TBX-0525-SRV, TC SYSTEM,          SIDESTREAM HTX-0285, 460V 60HZ DELUXE</b>			
MATERIAL	ENGR	ADJ	10/11/06				
FINISH	MFG	-	-	SIZE	MODEL NO.	DWG NO.	REV.
AS ASSEMBLED	WORK ORDER	-	-	C		<b>115468</b>	D
		SCALE	1:12	EST. WT.	1088 lb	SHEET	1 OF 1

DWG. NO. 115468 SH. REV. D