

EXCEPT AS OTHERWISE PROVIDED BY CONTRACT, THIS DRAWING AND SPECIFICATIONS SHALL NOT BE REPRODUCED, COPIED OR USED AS THE BASIS FOR MANUFACTURE OR SALE OF MATTER DEPICTED HEREIN WITHOUT THE EXPRESSED WRITTEN PERMISSION OF THE CLAUDE LAVAL CORPORATION, OR ITS ASSIGNEES.

THIS DRAWING HAS BEEN GENERATED AND IS MAINTAINED BY A CAD SYSTEM. CHANGES SHALL ONLY BE INCORPORATED AS DIRECTED BY AN APPROVED ENGINEERING CHANGE ORDER (ECO). PAPER COPIES ARE UNCONTROLLED.

REVISION HISTORY				
ZONE	REV	DESCRIPTION	DATE	APPROVED

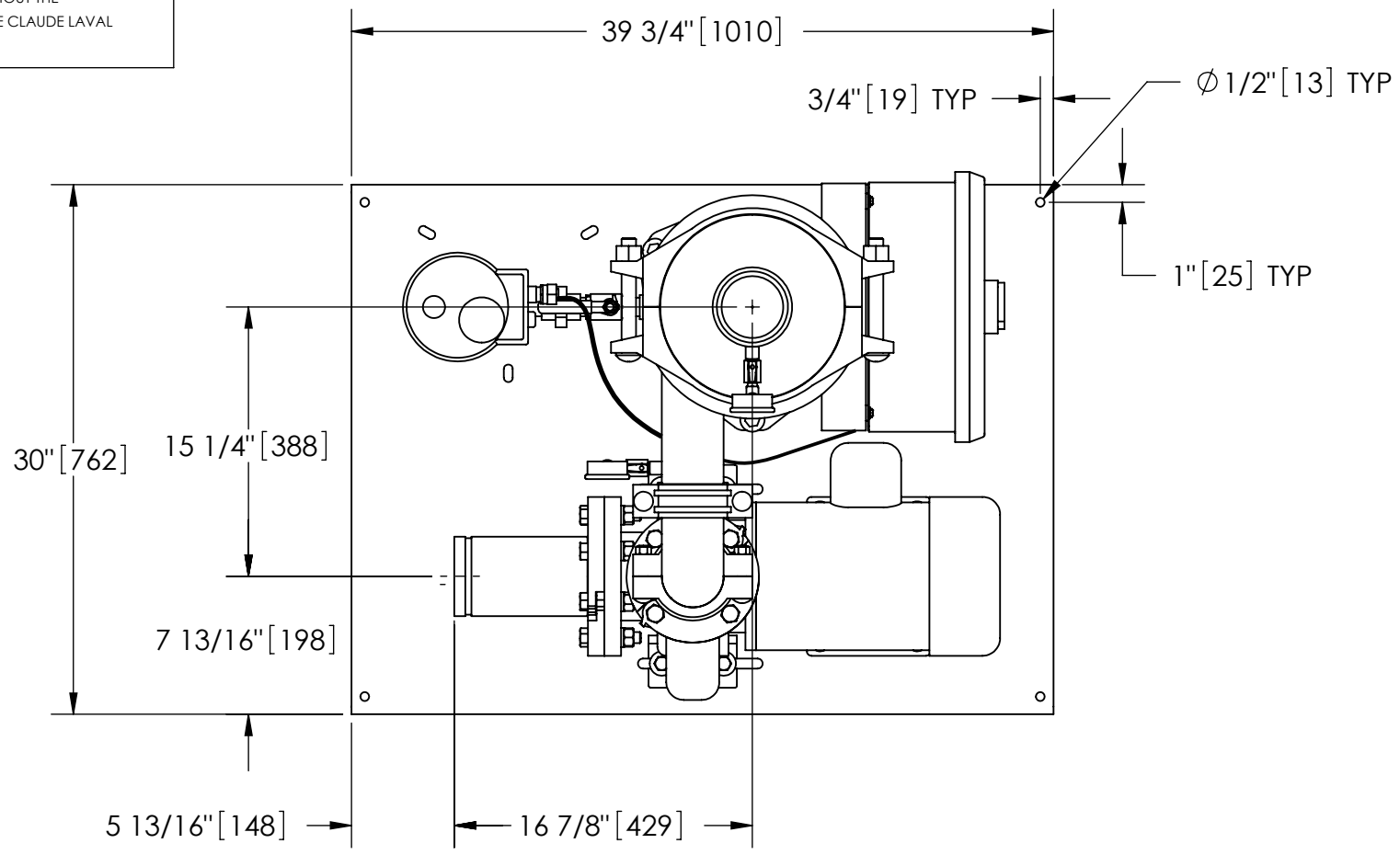

TOP VIEW

NOTES:

- INLET IS 4" PIPE (GROOVED).
- OUTLET IS 4" PIPE (GROOVED).
- PURGE OUTLET IS 3/4" PIPE.
- MAXIMUM PRESSURE: 150 psi (10.3 bar).
- MAXIMUM TEMPERATURE: 100°F (37.8°C).
- SPECIFIED FLOWRATE OF 280 gpm (64 m³/hr).
- FINISH: AS ASSEMBLED.
- POWER REQUIREMENT: 460V, 3PH, 60Hz.
- NEMA 4X MOTOR STARTER ENCLOSURE WITH SAFETY DISCONNECT AND H.O.A. SWITCH.
- APPROXIMATE DRY WEIGHT: 965 lbs (438 kg).
- INLET/OUTLET VALVE KIT, MODEL TCV-0280 RECOMMENDED.
- MINIMUM PIPE TO TB SYSTEM IS 6" PIPE.
- FLOODED SUCTION REQUIRED.

COMPONENT LIST:

- ① ELECTRICAL CONTROL BOX 460V 60Hz W/120V TRANSFORMER.
- ② SEPARATOR: HTX-0200-TC.
- ③ PUMP: 5 HP CENTRIFUGAL, 1750 rpm, 460V, 60Hz.
- ④ INLET/OUTLET PRESSURE GAUGES: 0-100 psi, GLYCERIN-FILLED.
- ⑤ PURGE EQUIPMENT: ABV-07-120V.

SUBMITTAL DRAWING

This drawing is submitted for spatial consideration only. Do not pre-plumb to these dimensions.

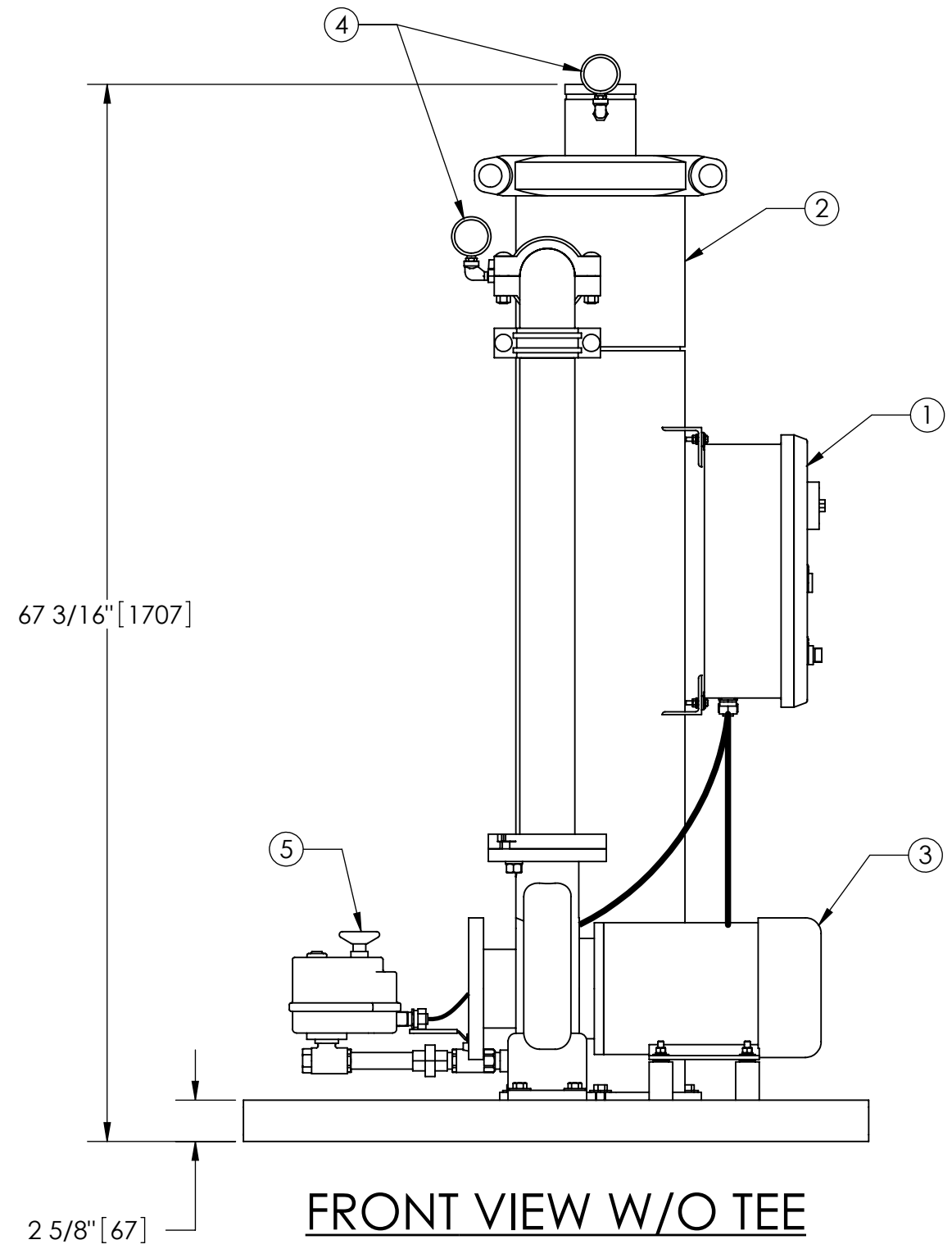

FRONT VIEW W/O TEE

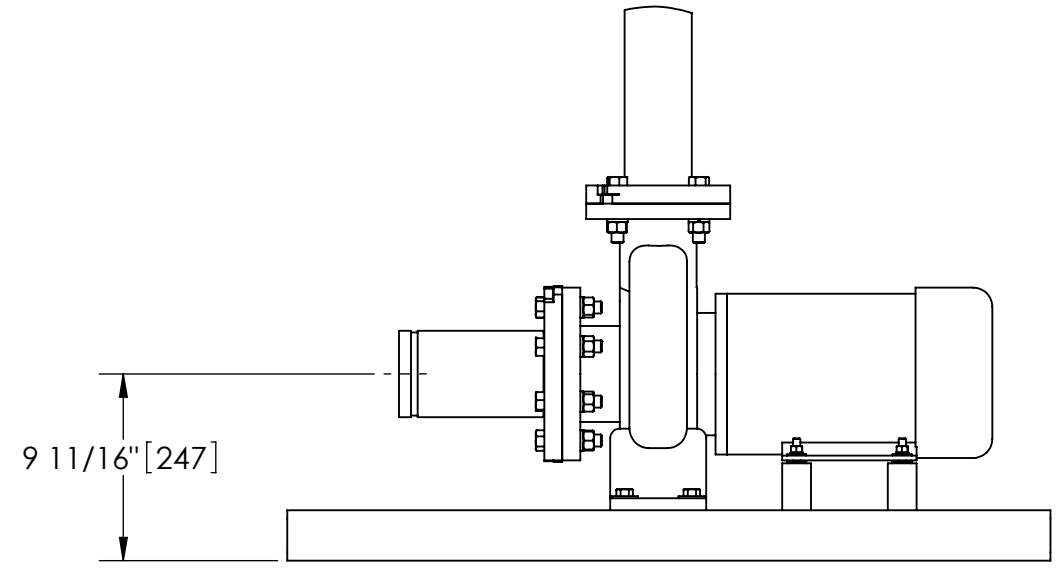

FRONT VIEW PUMP & TEE

UNLESS OTHERWISE SPECIFIED: DIMENSIONS ARE IN: INCHES [mm] TOLERANCES ARE: FRACTIONS    DECIMALS    ANGLES $\pm 1/2"$ .XX $\pm .01$ $\pm 1/4^\circ$ .XXX $\pm .005$ .XXXX $\pm .0005$	ENGINEERED FOR:		LAKOS		CLAUDE LAVAL CORP. FRESNO, CALIFORNIA 93727 WWW.LAKOS.COM				
	STANDARD		APPROVALS				DATE		
	DO NOT SCALE DRAWING	DRAWN	KFB/DLW	1/3/04	TITLE				
	MATERIAL	ENGR	HSK	9/7/05	TBX-0280-ABV, TC SYSTEM, SIDESTREAM HTX-0200, 460V 60HZ DELUXE				
FINISH	MFG	-	-	SIZE	MODEL NO.	DWG NO.	REV.		
AS ASSEMBLED	WORK ORDER	-	-	C	-	122715	D		
				SCALE	1:10	EST. WT.	965 lb	SHEET	1 OF 1

DWG NO. 122715  
 SHEET REV. D