

EXCEPT AS OTHERWISE PROVIDED BY CONTRACT, THIS DRAWING AND SPECIFICATIONS SHALL NOT BE REPRODUCED, COPIED OR USED AS THE BASIS FOR MANUFACTURE OR SALE OF MATTER DEPICTED HEREIN WITHOUT THE EXPRESSED WRITTEN PERMISSION OF THE LAKOS CORPORATION, OR ITS ASSIGNEES.

THIS DRAWING HAS BEEN GENERATED AND IS MAINTAINED BY A CAD SYSTEM. CHANGES SHALL ONLY BE INCORPORATED AS DIRECTED BY AN APPROVED ENGINEERING CHANGE ORDER (ECO). PAPER COPIES ARE UNCONTROLLED.

| REVISION HISTORY | | | | |
|------------------|-----|-------------------------|---------|----------|
| ZONE | REV | DESCRIPTION | DATE | APPROVED |
| | A | RELEASED FOR PRODUCTION | 8/30/19 | TPF |

NOTES:

1. INLET IS 4" PIPE (125# ANSI FLANGED).
2. OUTLET IS 4" PIPE (GROOVED).
3. PURGE OUTLET IS 3/4" PIPE.
4. MAXIMUM PRESSURE: 150 psi (10.3 bar).
5. MAXIMUM TEMPERATURE: 100°F (37.8°C).
6. SPECIFIED FLOWRATE OF 280 gpm (64 m/hr).
7. FINISH: AS ASSEMBLED.
8. POWER REQUIREMENT: 460V, 3PH, 60Hz.
9. NEMA 4X MOTOR STARTER ENCLOSURE WITH SAFETY DISCONNECT AND H.O.A. SWITCH.
10. APPROXIMATE DRY WEIGHT: 1124 lbs (510 kg).
11. INLET/OUTLET VALVE KIT, MODEL TCV-0280-PLUS RECOMMENDED.
12. MINIMUM PIPE FROM TOWER BASIN TO TP SYSTEM IS 6" PIPE.
13. FLOODED SUCTION REQUIRED.
14. MAXIMUM BASIN SIZE 230 sq ft.

COMPONENT LIST:

- 1 ELECTRICAL CONTROL BOX 460V 60Hz W/120V TRANSFORMER.
- 2 SEPARATOR: HTX-0200-TC.
- 3 PUMP: 10 HP CENTRIFUGAL, 3500 rpm, 460V, 60Hz.
- 4 INLET/OUTLET PRESSURE GAUGES: 0-160 psi, GLYCERIN-FILLED.
- 5 PURGE EQUIPMENT: SRV-816.
- 6 DIFFERENTIAL PRESSURE INDICATOR:
(AVAILABLE WITH DRY CONTACT-MODEL DHE-15-S.
ORDER SEPARATELY).
- 7 HOSE ATTACHED IN FIELD WITH QUICK DISCONNECT COUPLINGS.
- 8 FILTER VESSEL, 2" HRF-930-MP-2-BL, 304SS
- 9 BASKET STRAINER.

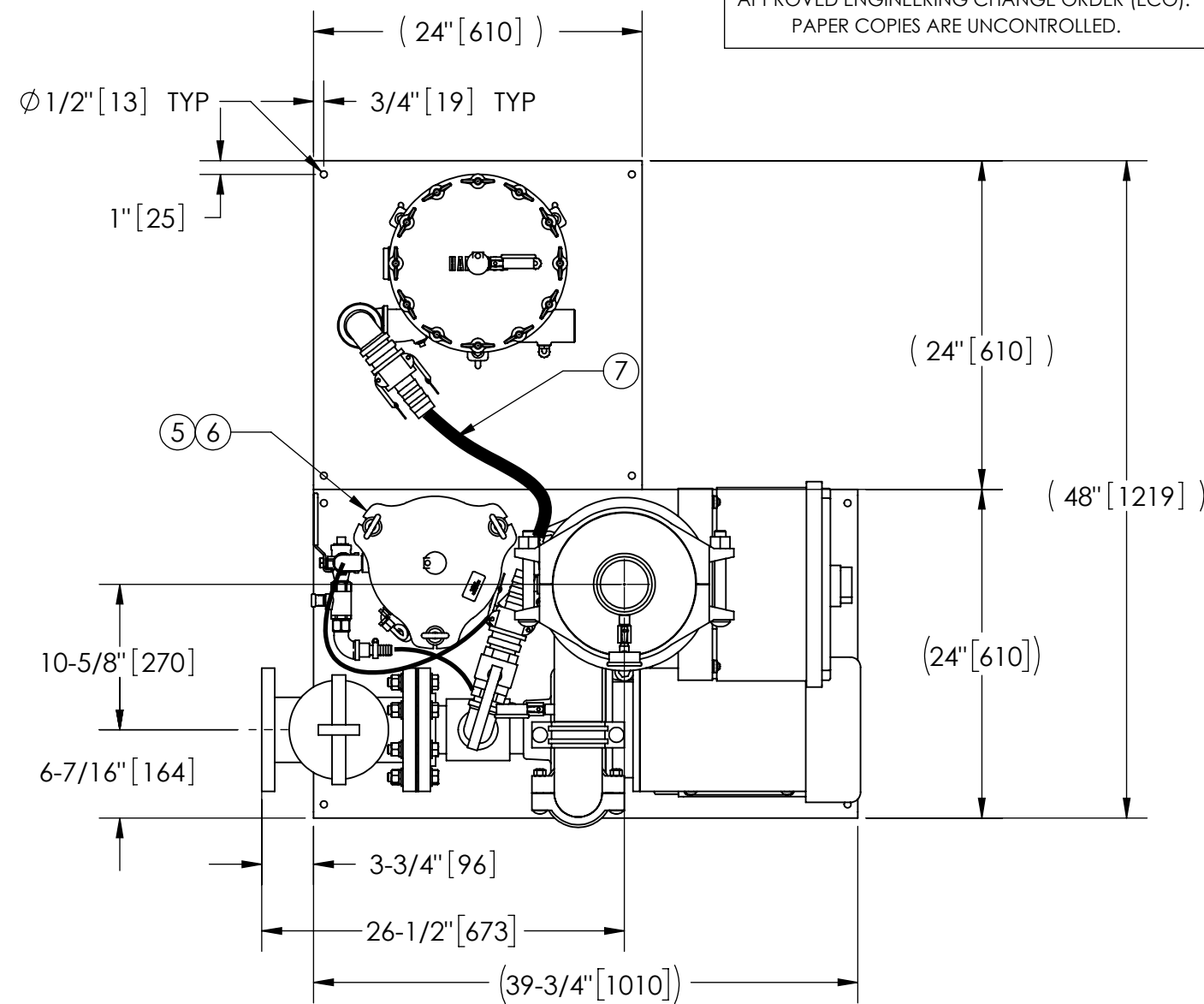

TOP VIEW
SEPARATOR OUTLET SPOOL HIDDEN

SUBMITTAL DRAWING

This drawing is submitted for spatial consideration only. Do not pre-plumb to these dimensions.

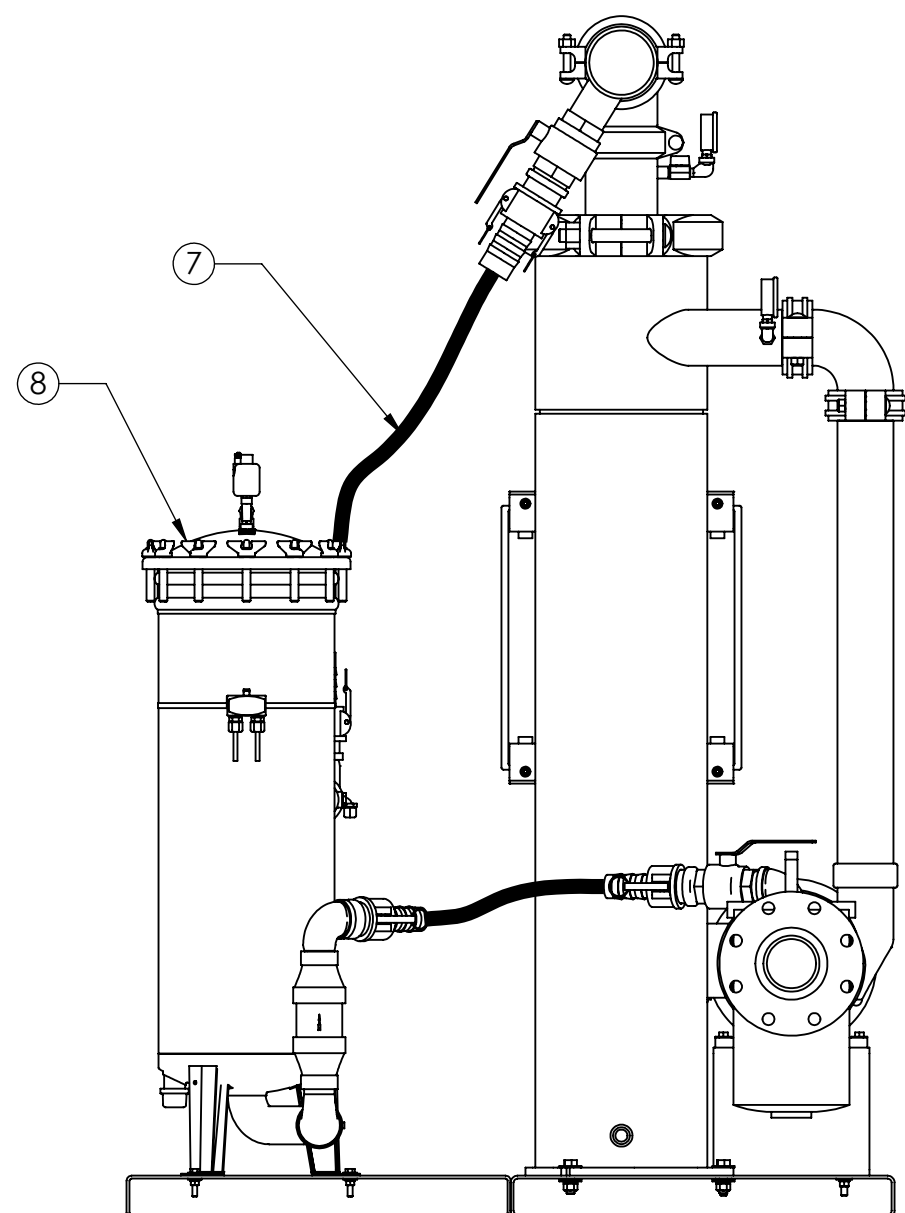

SIDE VIEW W/O SRV

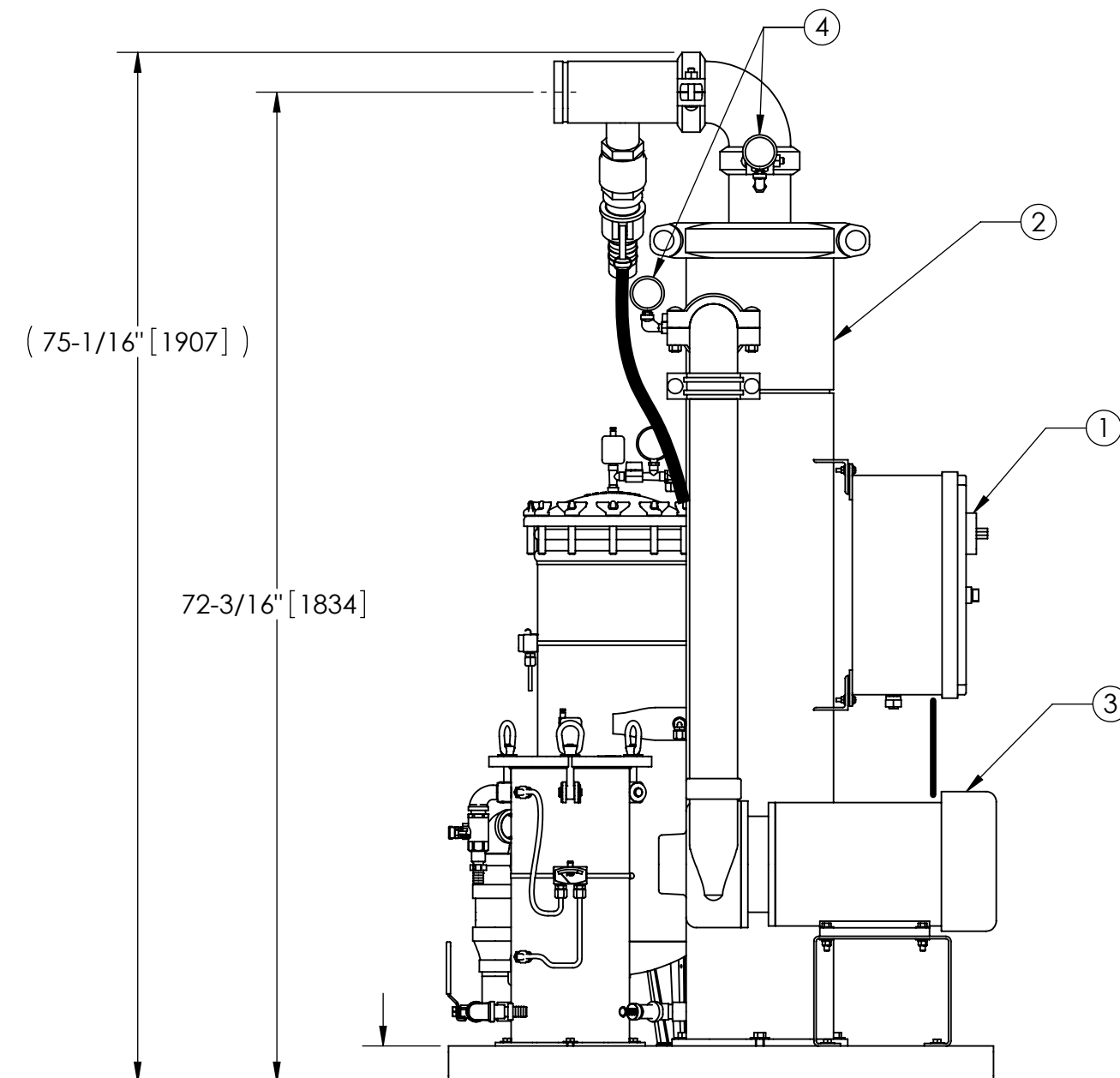

FRONT VIEW W/O STRAINER

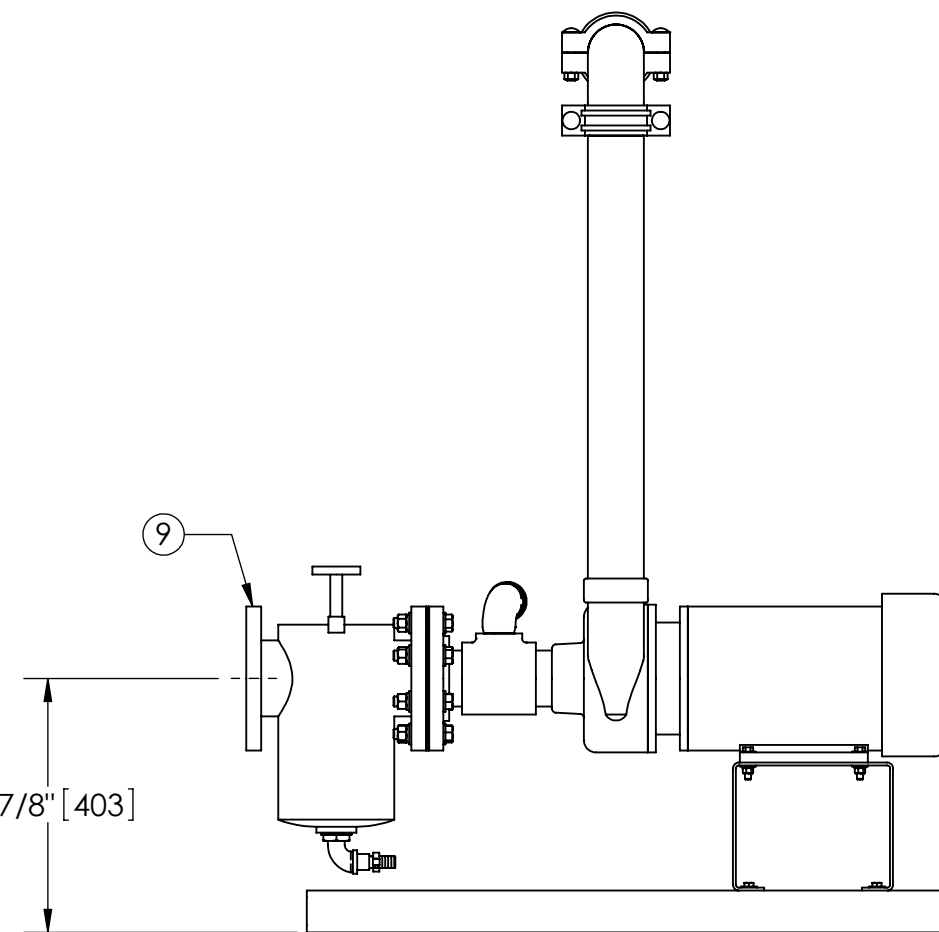

FRONT VIEW PUMP/STRAINER/SPOOL

| | | | | | |
|--|------------|------------------------------------|--|------------------|----------------|
| UNLESS OTHERWISE SPECIFIED: DIMENSIONS ARE IN: INCHES [mm] TOLERANCES ARE: FRACTIONS DECIMALS ANGLES ± 1" .XX ± .01 ± 1/4" .XXX ± .005 .XXXX ± .0005 | | ENGINEERED FOR: STANDARD | | | |
| DO NOT SCALE DRAWING | APPROVALS | DATE | TITLE | | |
| MATERIAL PER LAKOS SPEC | ENGR HSK | 11/17/05 | TPX-0280-SRV, TCX SYSTEM HRF-930 VESSEL, SWEEPER HTX-0200, 460V 60HZ PLUS | | |
| FINISH AS ASSEMBLED | REVIEW - | - | SIZE C | MODEL NO. | DWG NO. 123375 |
| | WORK ORDER | QTY. | SCALE 1:12 | EST. WT. 1124 lb | SHEET 1 OF 1 |

DWG NO. 123375
SHEET 1 REV. A