

EXCEPT AS OTHERWISE PROVIDED BY CONTRACT, THIS DRAWING AND SPECIFICATIONS SHALL NOT BE REPRODUCED, COPIED OR USED AS THE BASIS FOR MANUFACTURE OR SALE OF MATTER DEPICTED HEREIN WITHOUT THE EXPRESSED WRITTEN PERMISSION OF THE CLAUDE LAVAL CORPORATION, OR ITS ASSIGNEES.

THIS DRAWING HAS BEEN GENERATED AND IS MAINTAINED BY A CAD SYSTEM. CHANGES SHALL ONLY BE INCORPORATED AS DIRECTED BY AN APPROVED ENGINEERING CHANGE ORDER (ECO). PAPER COPIES ARE UNCONTROLLED.

REVISION HISTORY				
ZONE	REV	DESCRIPTION	DATE	APPROVED

NOTES:

1. INLET IS 3" PIPE (125# ANSI FLANGED).
2. OUTLET IS 3" PIPE (GROOVED).
3. PURGE OUTLET IS 3/4" PIPE.
4. MAXIMUM PRESSURE: 150 psi (10.3 bar).
5. MAXIMUM TEMPERATURE: 100°F (37.8°C).
6. SPECIFIED FLOWRATE OF 200 gpm (45 m³/hr).
7. FINISH: AS ASSEMBLED.
8. POWER REQUIREMENT: 460V, 3PH, 60Hz.
9. NEMA 4X MOTOR STARTER ENCLOSURE WITH SAFETY DISCONNECT AND H.O.A. SWITCH.
10. APPROXIMATE DRY WEIGHT: 801 lbs (363 kg).
11. INLET/OUTLET VALVE KIT, MODEL TCV-0200-PLUS RECOMMENDED.
12. MINIMUM PIPE FROM TOWER BASIN TO TP SYSTEM IS 4" PIPE.
13. FLOODED SUCTION REQUIRED.
14. MAXIMUM BASIN SIZE 170 sq ft.

COMPONENT LIST:

- ① ELECTRICAL CONTROL BOX 460V 60Hz W/120V TRANSFORMER.
- ② SEPARATOR: HTX-0130-TC.
- ③ PUMP: 7.5 HP CENTRIFUGAL, 3500 rpm, 460V, 60Hz.
- ④ INLET/OUTLET PRESSURE GAUGES: 0-100 psi, GLYCERIN-FILLED.
- ⑤ PURGE EQUIPMENT: SRV-816.
- ⑥ DIFFERENTIAL PRESSURE INDICATOR: (AVAILABLE WITH DRY CONTACT-MODEL DHE-15-S. ORDER SEPARATELY).
- ⑦ HOSE ATTACHED IN FIELD WITH QUICK DISCONNECT COUPLINGS.
- ⑧ FILTER VESSEL, 2" HRF-930-MP-2-BL, 304SS
- ⑨ BASKET STRAINER.

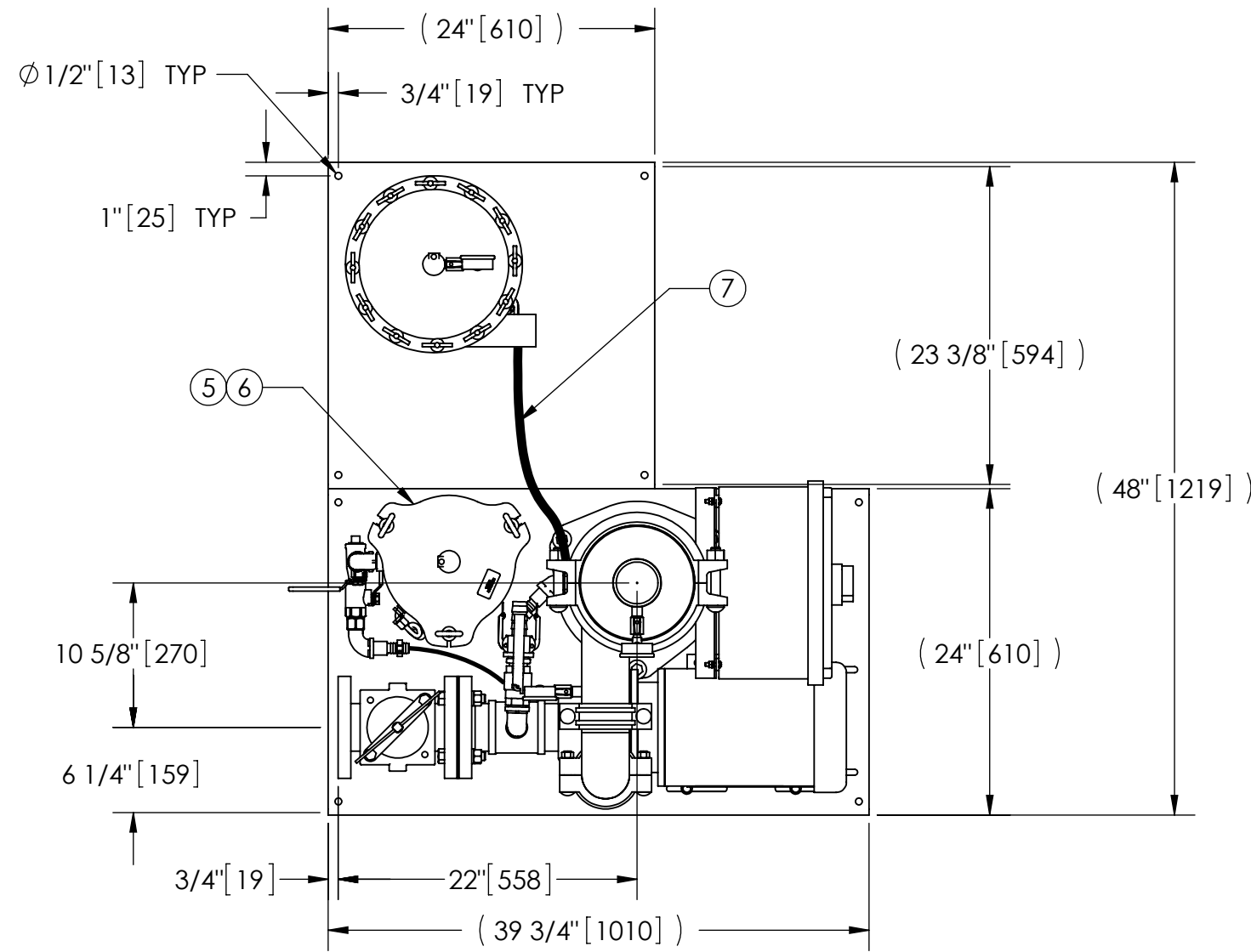

TOP VIEW

SUBMITTAL DRAWING

This drawing is submitted for spatial consideration only. Do not pre-plumb to these dimensions.

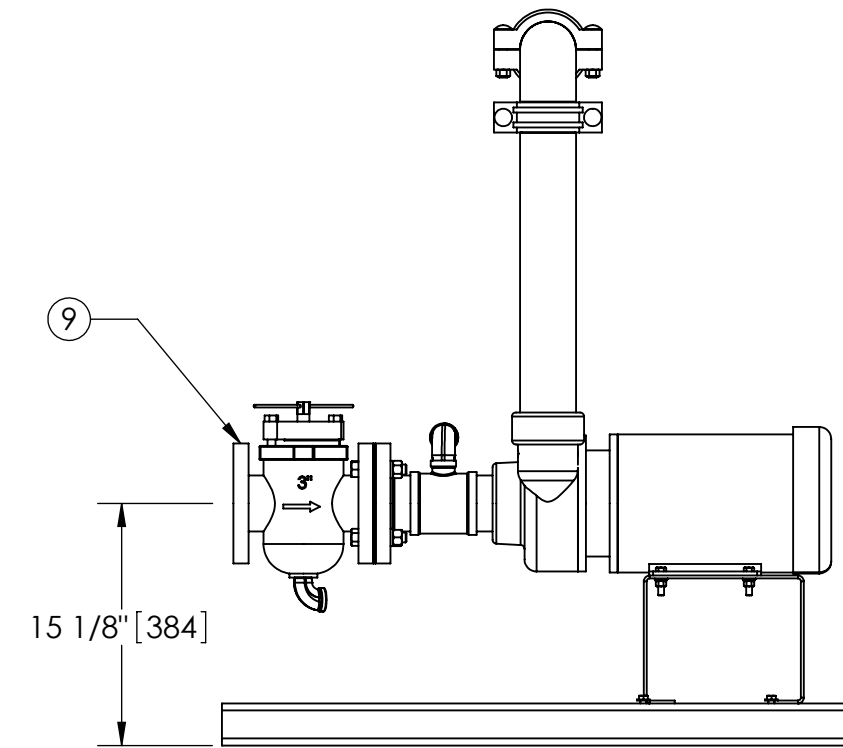

FRONT VIEW PUMP/STRAINER

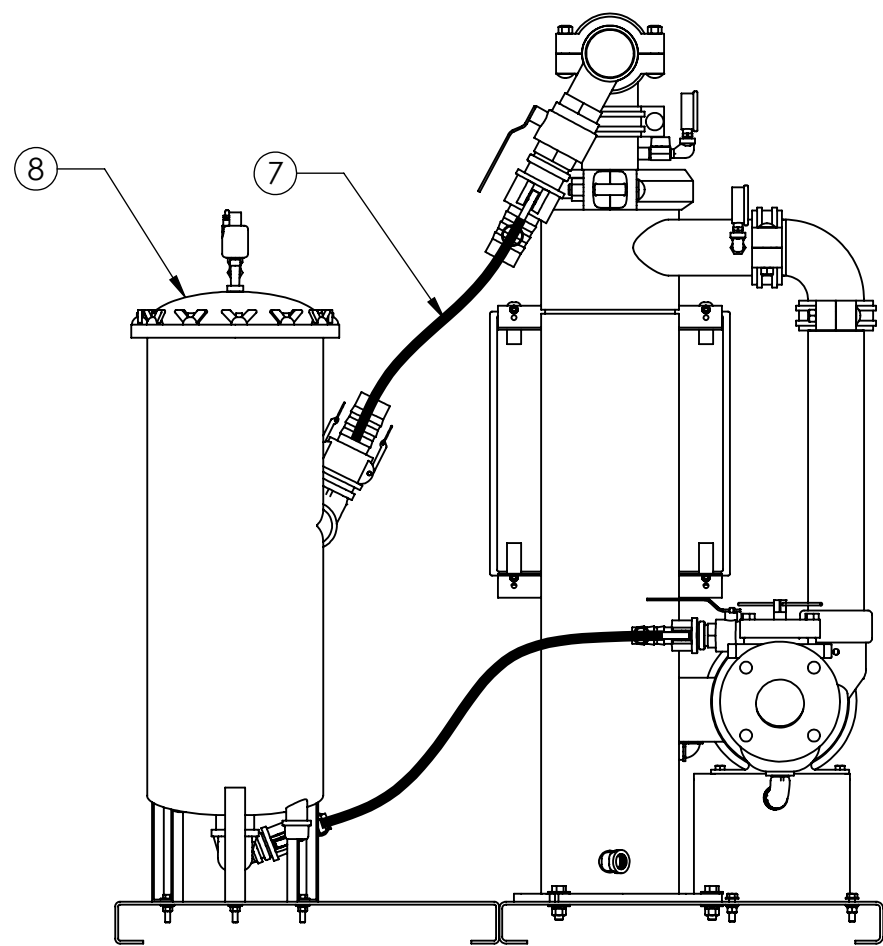

SIDE VIEW W/O SRV

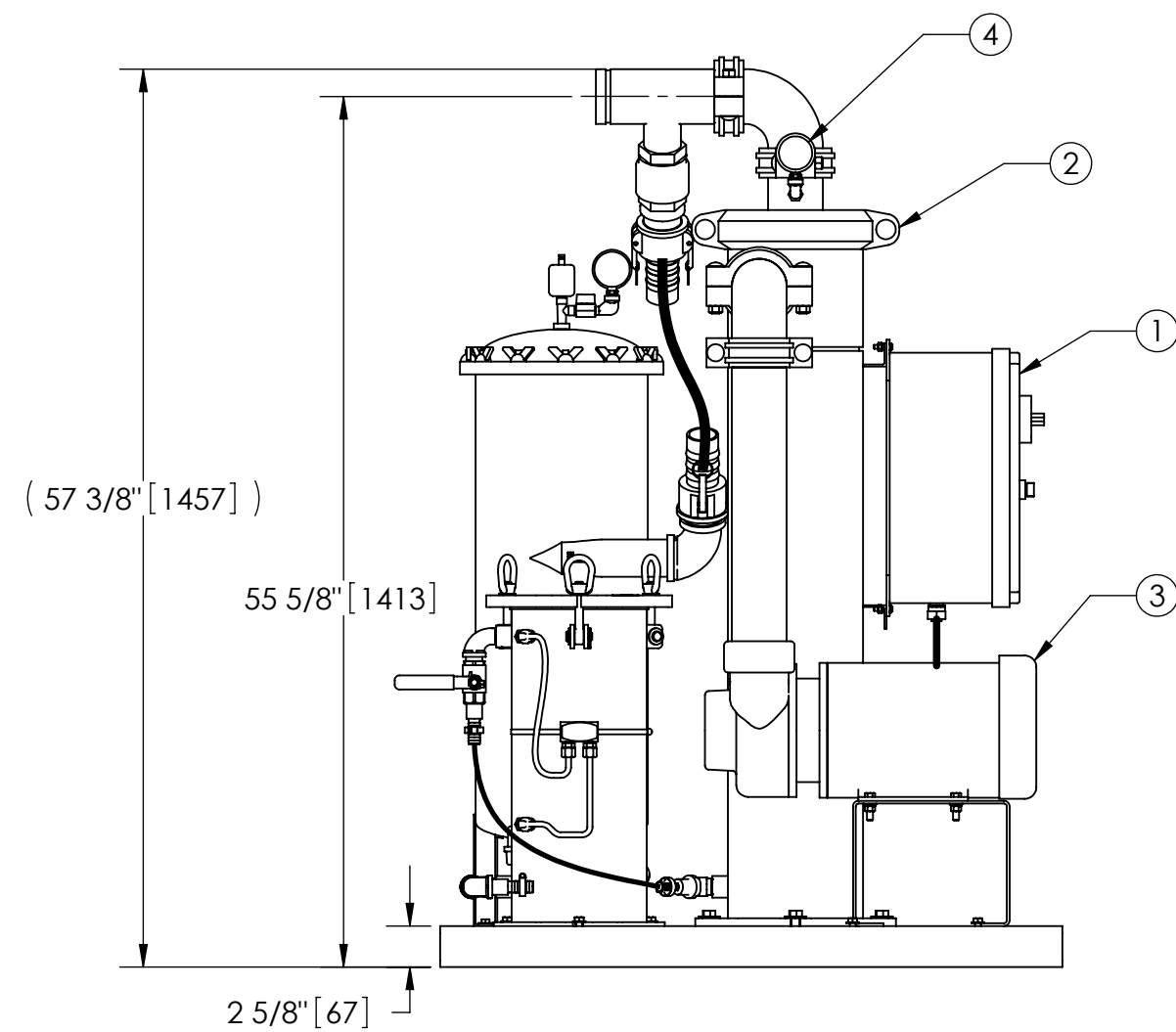

FRONT VIEW W/O STRAINER/SRV

<small>UNLESS OTHERWISE SPECIFIED: DIMENSIONS ARE IN: INCHES (mm) TOLERANCES ARE: FRACTIONS DECIMALS ANGLES ± 1/2" .XX ± .01 ± 1/4" XXX ± .005 XXXX ± .0005</small>	ENGINEERED FOR:		LAKOS CLAUDE LAVAL CORP. FRESNO, CALIFORNIA 93727 WWW.LAKOS.COM			<small>LAVAL UNDERGROUND SURVEYS</small>		
	STANDARD							
	DO NOT SCALE DRAWING	APPROVALS	DATE	TITLE: TPX-0200-SRV, TCX SYSTEM HRF-930 VESSEL, SWEEPER HTX-0130, 460V 60HZ PLUS				
	MATERIAL: PER LAKOS SPEC	DRAWN: DLW	12/22/04	ENGR: HSK	6/3/05	SIZE: C	MODEL NO.	DWG NO. 123374
FINISH: AS ASSEMBLED	MFG: -	-	WORK ORDER	QTY.	SCALE: 1:12	EST. WT. 801 lb	SHEET 1 OF 1	

DWG. NO. 123374 SHEET 1 REV. -