

EXCEPT AS OTHERWISE PROVIDED BY CONTRACT, THIS DRAWING AND SPECIFICATIONS SHALL NOT BE REPRODUCED, COPIED OR USED AS THE BASIS FOR MANUFACTURE OR SALE OF MATTER DEPICTED HEREIN WITHOUT THE EXPRESSED WRITTEN PERMISSION OF THE CLAUDE LAVAL CORPORATION, OR ITS ASSIGNEES.

THIS DRAWING HAS BEEN GENERATED AND IS MAINTAINED BY A CAD SYSTEM. CHANGES SHALL ONLY BE INCORPORATED AS DIRECTED BY AN APPROVED ENGINEERING CHANGE ORDER (ECO). PAPER COPIES ARE UNCONTROLLED.

REVISION HISTORY				
ZONE	REV	DESCRIPTION	DATE	APPROVED

NOTES:

1. INLET IS 8" PIPE (150# ANSI FLANGED).
2. OUTLET IS 6" PIPE (GROOVED).
3. PURGE OUTLET IS 1-1/2" PIPE.
4. MAXIMUM PRESSURE: 100 psi (6.9 bar).
5. MAXIMUM TEMPERATURE: 100°F (37.8°C).
6. SPECIFIED FLOWRATE OF 825 gpm (187 m³/hr).
7. FINISH: AS ASSEMBLED.
8. POWER REQUIREMENT: 460V, 3PH, 60Hz.
9. NEMA 4X MOTOR STARTER ENCLOSURE WITH SAFETY DISCONNECT AND H.O.A. SWITCH.
10. APPROXIMATE DRY WEIGHT: 2535 lbs (1150 kg).
11. INLET/OUTLET VALVE KIT, MODEL TCV-0825-PLUS RECOMMENDED.
12. MINIMUM PIPE TO SP SYSTEM IS 8" PIPE.
13. FLOODED SUCTION REQUIRED.

COMPONENT LIST:

- ① ELECTRICAL CONTROL BOX 460V 60Hz W/120V TRANSFORMER.
- ② SEPARATOR: HTX-0450-TC.
- ③ PUMP: 20 HP CENTRIFUGAL, 1750 rpm, 460V, 60Hz.
- ④ INLET/OUTLET PRESSURE GAUGES: 0-100 psi, GLYCERIN-FILLED.
- ⑤ PURGE EQUIPMENT: SRV-816.
- ⑥ DIFFERENTIAL PRESSURE INDICATOR: (AVAILABLE WITH DRY DRY CONTACT-MODEL DHE-15-S. ORDER SEPARATELY).
- ⑦ HOSE ATTACHED IN FIELD WITH QUICK DISCONNECT COUPLINGS.
- ⑧ FILTER VESSEL, 2" HRF-930-MP-2-BL, 304 SS

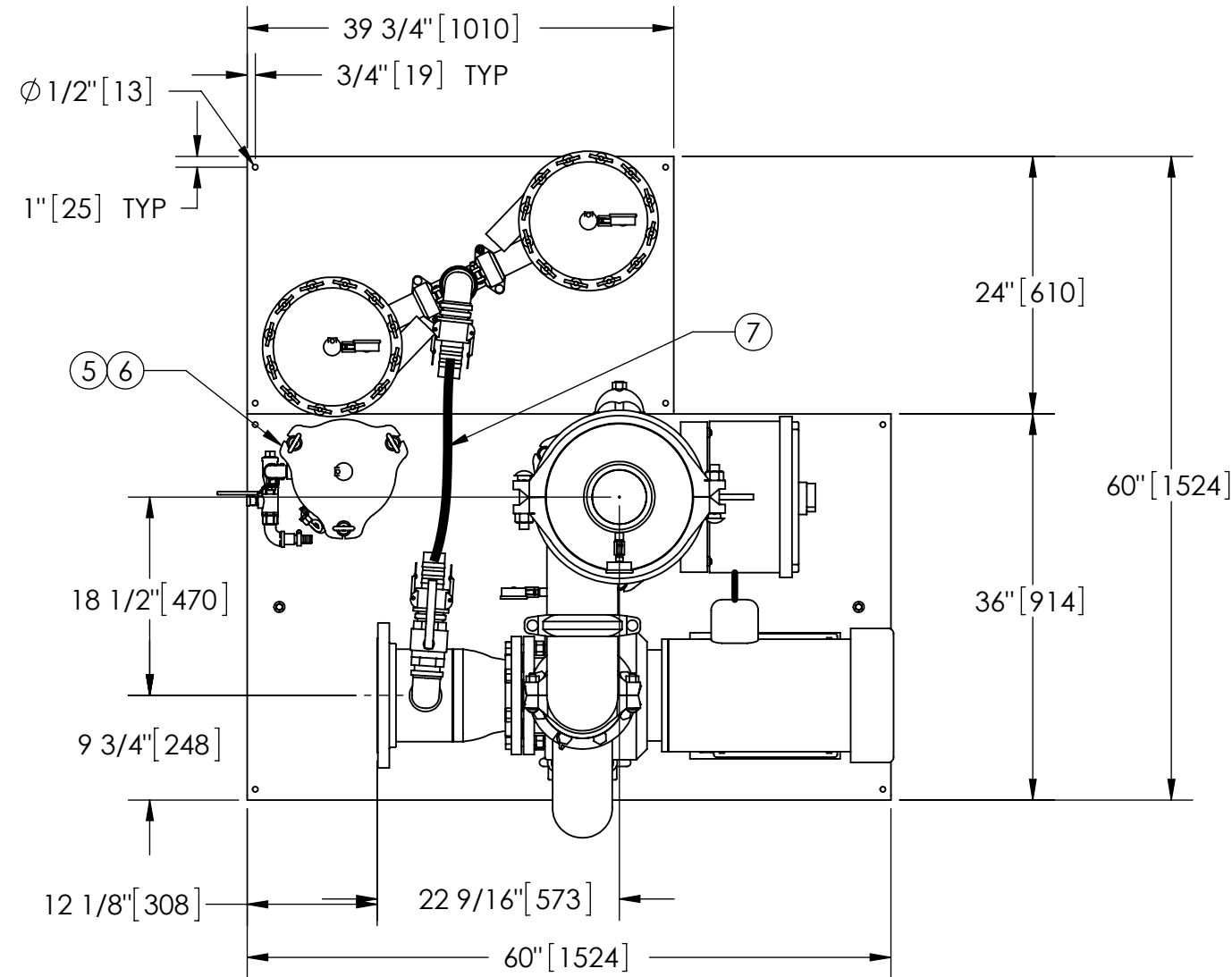

TOP VIEW

SUBMITTAL DRAWING

This drawing is submitted for spatial consideration only. Do not pre-plumb to these dimensions.

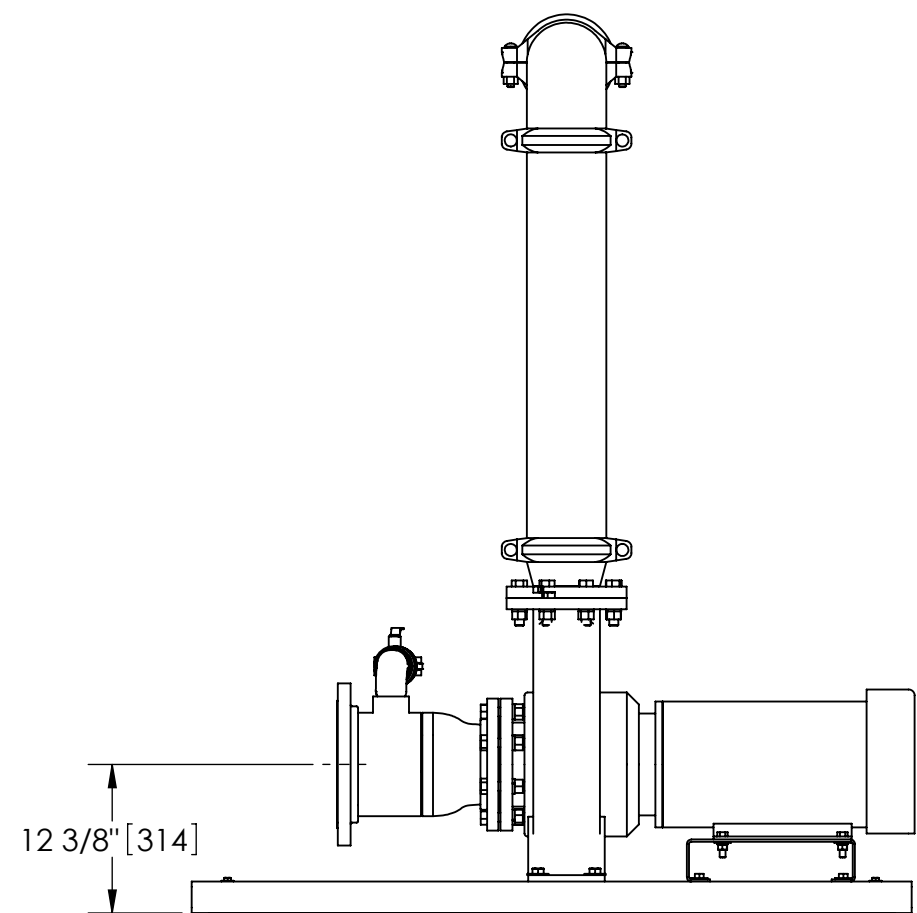

FRONT VIEW PUMP/SPOOL

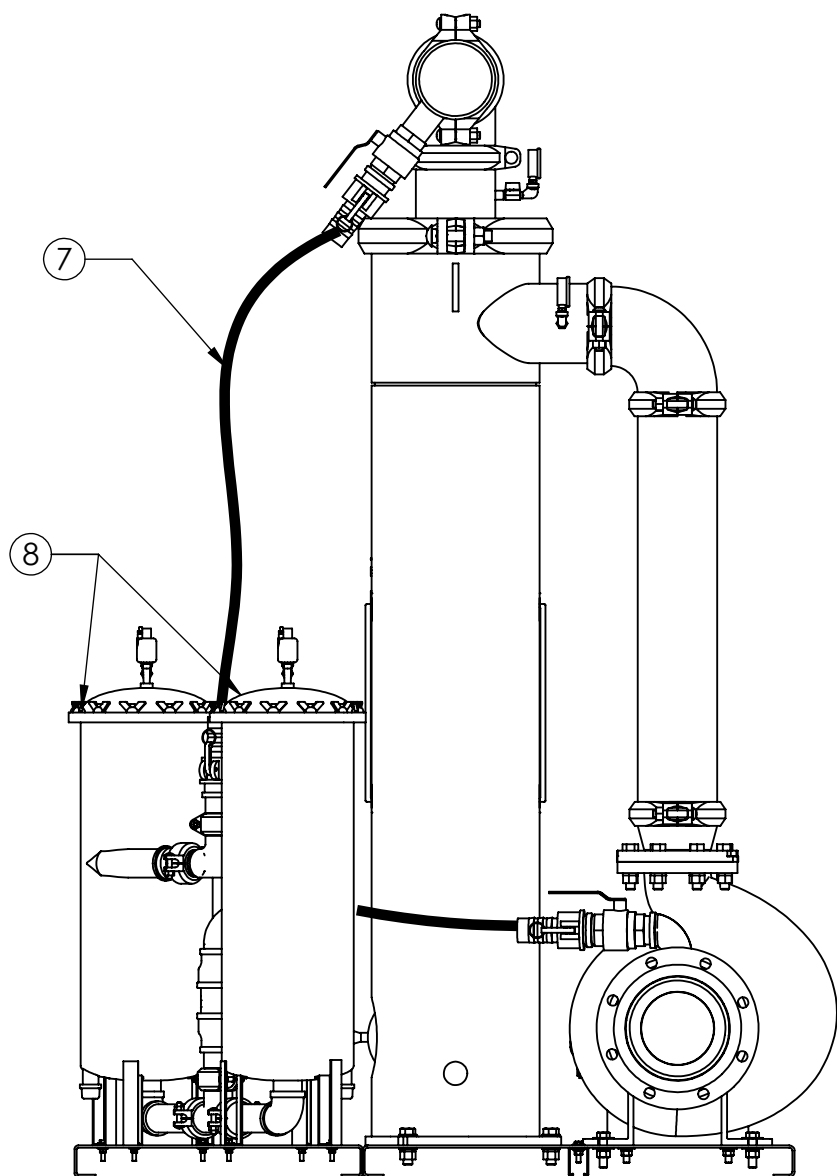

SIDE VIEW W/O SRV

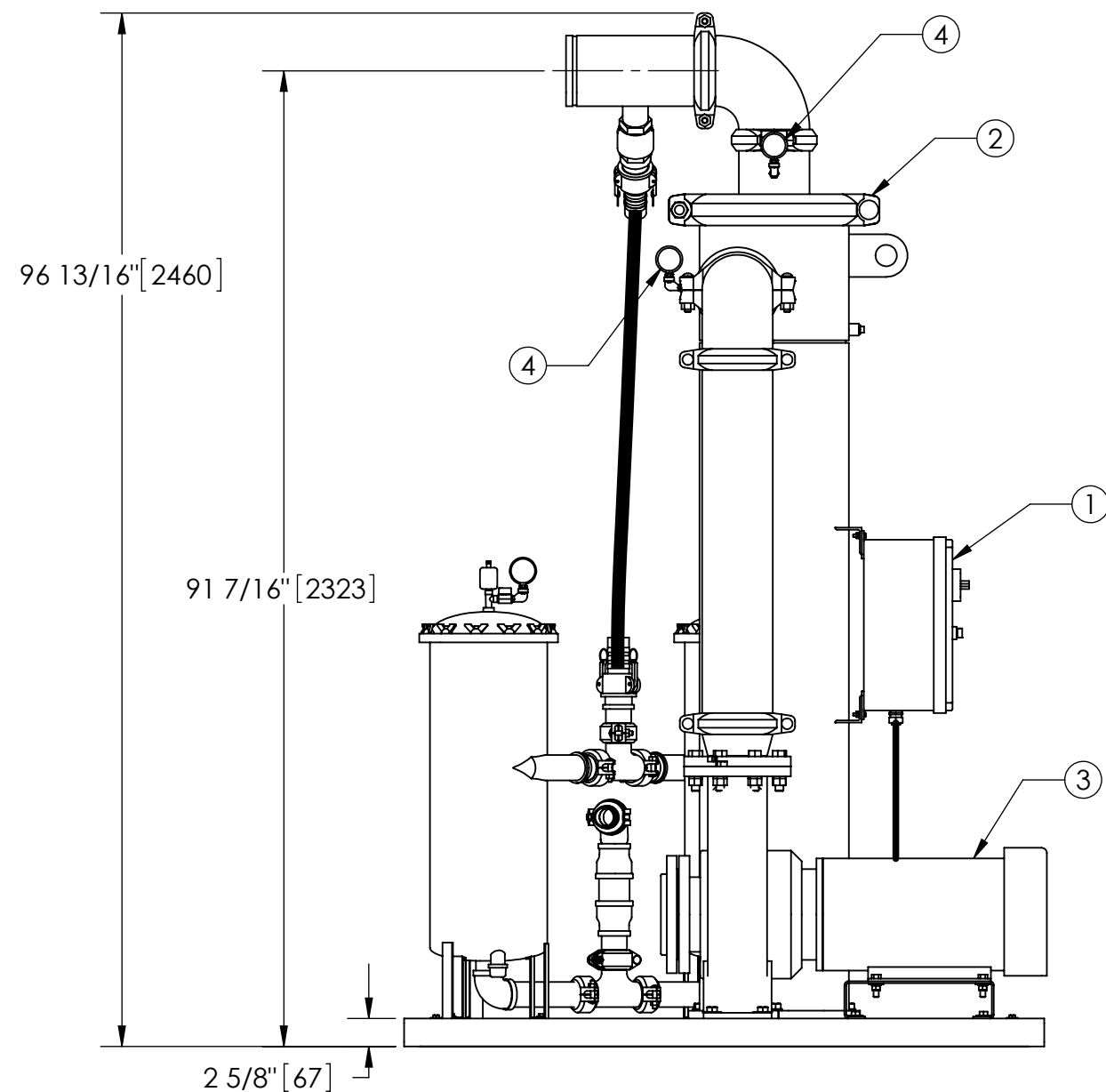

FRONT VIEW W/O SPOOL/SRV

UNLESS OTHERWISE SPECIFIED: DIMENSIONS ARE IN: INCHES [mm] TOLERANCES ARE: FRACTIONS DECIMALS ANGLES ± 1/2" XX ± .01 ± 1/4" XXX ± .005 XXXX ± .0005		ENGINEERED FOR: STANDARD		LAKOS. CLAUDE LAVAL CORP. FRESNO, CALIFORNIA 93727 WWW.LAKOS.COM	
DO NOT SCALE DRAWING		APPROVALS	DATE	TITLE	
MATERIAL SEE PARTS LIST		DRAWN DLW	2/14/05	SPX-0825-SRV, TBX SYSTEM .35 MICRON, SIDESTREAM HTX-0450, 460V 60HZ PLUS	
FINISH AS ASSEMBLED		ENGR	-	SIZE C	MODEL NO.
		MFG	-	DWG NO.	123477
		WORK ORDER	QTY.	SCALE	1:16
				EST. WT.	SHEET 1 OF 1

DWG NO. 123477 SH 1 REV -