

EXCEPT AS OTHERWISE PROVIDED BY CONTRACT, THIS DRAWING AND SPECIFICATIONS SHALL NOT BE REPRODUCED, COPIED OR USED AS THE BASIS FOR MANUFACTURE OR SALE OF MATTER DEPICTED HEREIN WITHOUT THE EXPRESSED WRITTEN PERMISSION OF THE CLAUDE LAVAL CORPORATION, OR ITS ASSIGNEES.

NOTES:

1. OUTLET FLANGE IS 12" ANSI B16.5 HOLE PATTERN REQUIRING 12X 7/8" BOLTS (BOLTS AND GASKETS NOT INCLUDED).
2. REQUIRED BACKWASH PRESSURE: 75-100 psi (5.1-6.9 kPa).
3. APPROXIMATE BACKWASH FLOW AT PROPER PRESSURE: 36 gpm. (8.0 m³/hr).
4. MAXIMUM FLOWRATE: 1900 gpm (431 m³/hr).
5. APPROXIMATE DRY WEIGHT: 69 lb (31 kg).
6. FINISH: GLASSBLAST

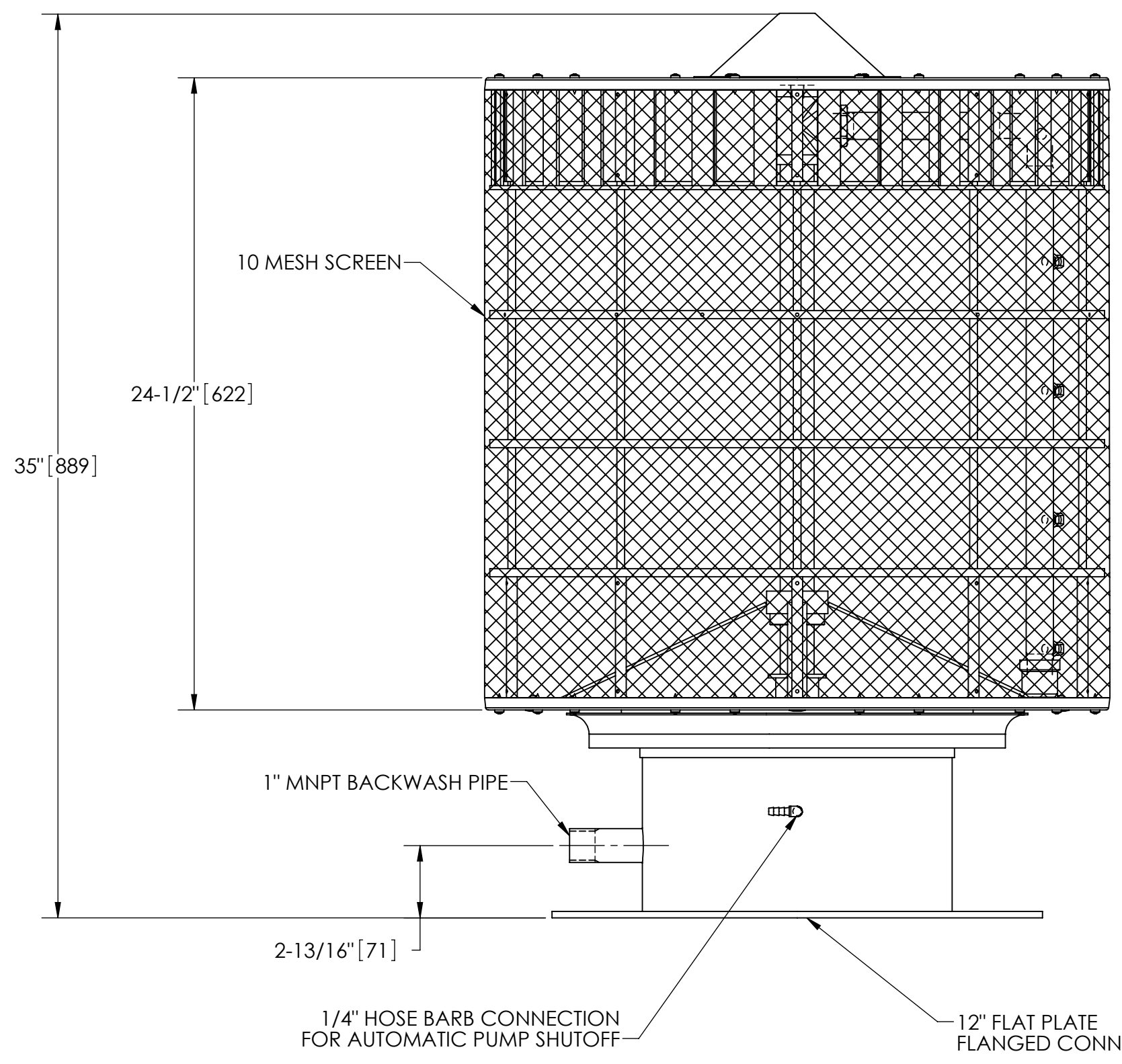
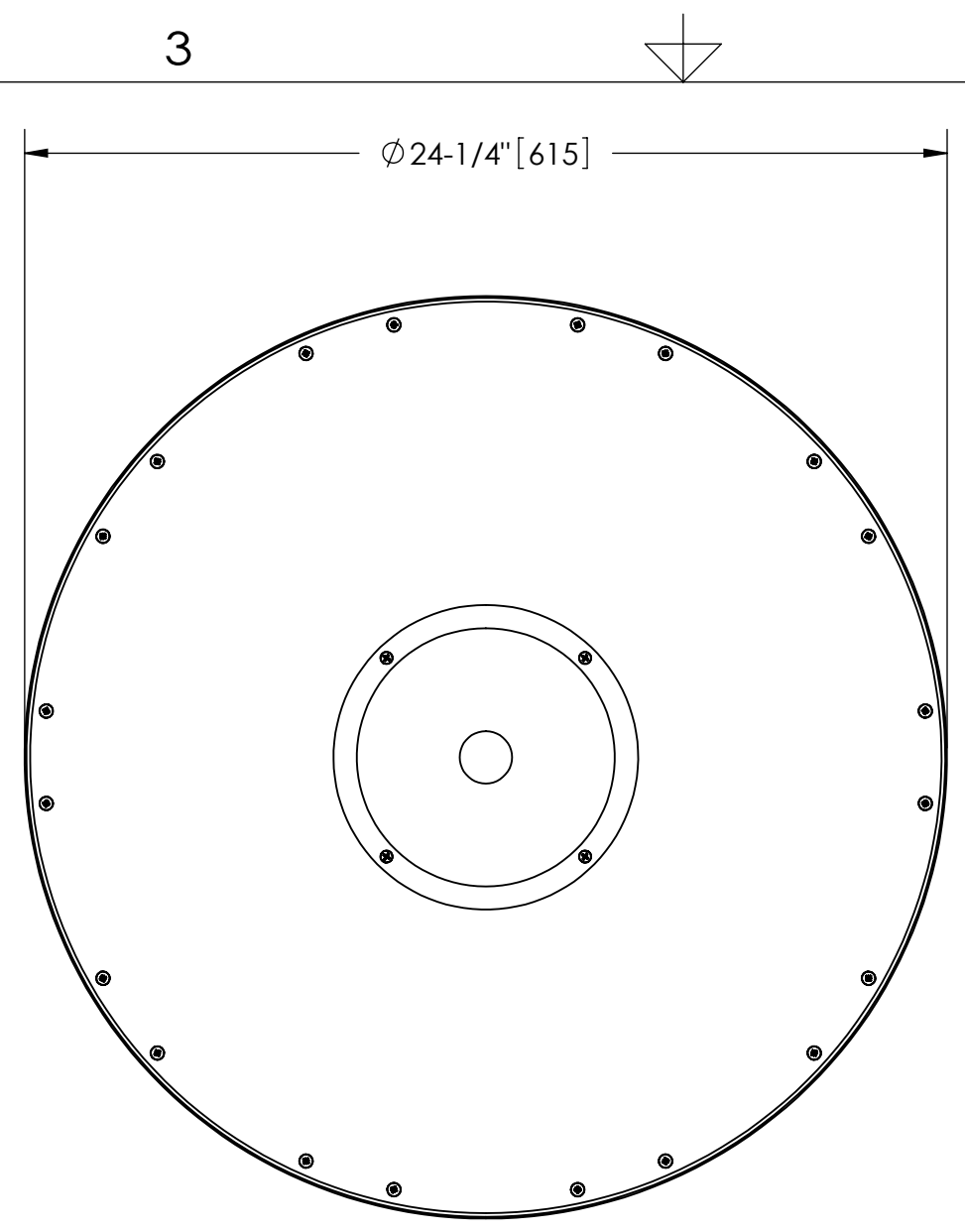

REVISIONS				
ZONE	REV.	DESCRIPTION	DATE	APPROVED

THIS DRAWING HAS BEEN GENERATED AND IS MAINTAINED BY A CAD SYSTEM. CHANGES SHALL ONLY BE INCORPORATED AS DIRECTED BY AN APPROVED ENGINEERING CHANGE ORDER (ECO). PAPER COPIES ARE UNCONTROLLED.

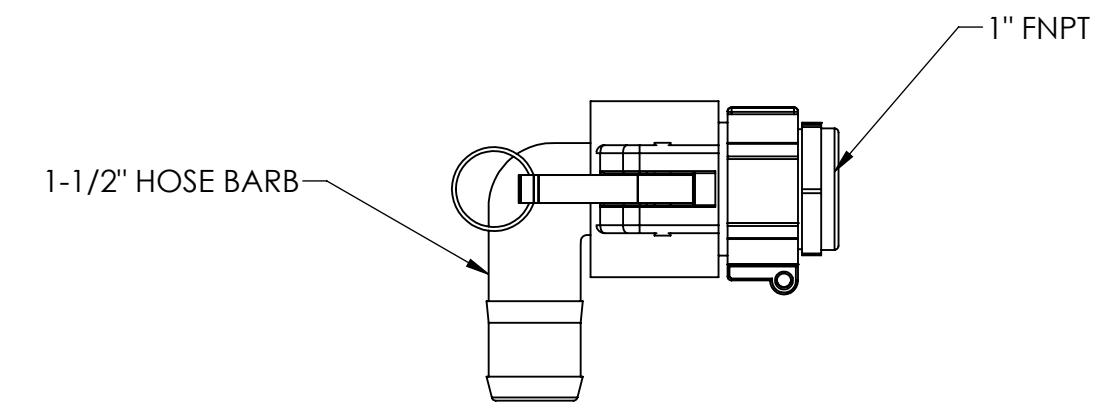

1-1/2" 90° QUICK DISCONNECT ADAPTER (INCLUDED) SCALE 1:3

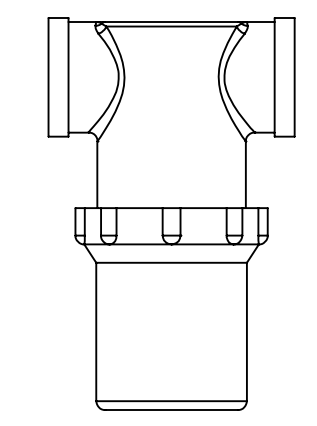

1-1/2" INLINE STRAINER (INCLUDED) 1:4

**SUBMITTAL DRAWING**

This drawing is submitted for spatial consideration only. Do not pre-plumb to these dimensions.

UNLESS OTHERWISE SPECIFIED: DIMENSIONS ARE IN: INCHES (mm) TOLERANCES ARE: FRACTIONS    DECIMALS    ANGLES ± 1/4"    .XX ± .01    ± 1/4° .XXX ± .005    .XXXX ± .0005		ENGINEERED FOR: <b>STANDARD</b>		CLAUDE LAVAL CORP. FRESNO, CALIFORNIA 93727 WWW.LAKOS.COM		LAVAL UNDERGROUND SURVEYS	
DO NOT SCALE DRAWING		APPROVALS	DATE	TITLE			
MATERIAL PER LAKOS SPEC		DRAWN	2/08/08	ISF-2424-10, PC SCREEN			
FINISH SEE NOTES		ENGR	-	1900 gpm, STAINLESS STEEL			
		MFG	-	SIZE	MODEL NO.	DWG NO.	REV.
		WORK ORDER	QTY.	C		103079	01
				SCALE	1:5	EST. WT.	69 lb
				SHEET		1 OF 1	

DWG. NO. 103079 SHEET 1 REV. 01