

EXCEPT AS OTHERWISE PROVIDED BY CONTRACT, THIS DRAWING AND SPECIFICATIONS SHALL NOT BE REPRODUCED, COPIED OR USED AS THE BASIS FOR MANUFACTURE OR SALE OF MATTER DEPICTED HEREIN WITHOUT THE EXPRESSED WRITTEN PERMISSION OF THE LAKOS CORPORATION, OR ITS ASSIGNEES.

THIS DRAWING HAS BEEN GENERATED AND IS MAINTAINED BY A CAD SYSTEM. CHANGES SHALL ONLY BE INCORPORATED AS DIRECTED BY AN APPROVED ENGINEERING CHANGE ORDER (ECO). PAPER COPIES ARE UNCONTROLLED.

REVISION HISTORY				
ECN	REV	DESCRIPTION	DATE	APPROVED
408	L	UPDATED TANK	11/20/20	TPF

D

C

B

A

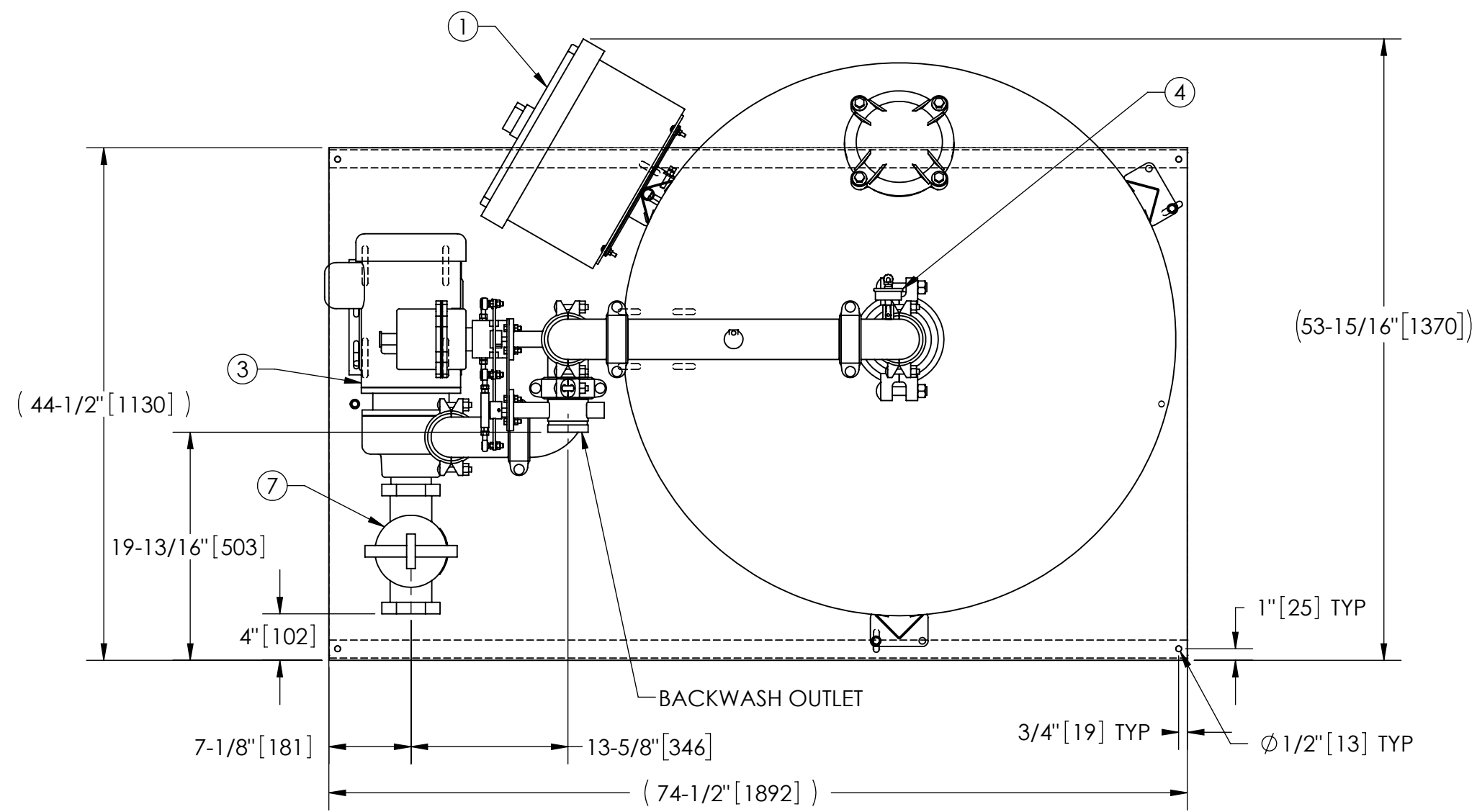

NOTES:

1. INLET IS 3" PIPE (FNPT).
2. OUTLET IS 3" PIPE (GROOVED).
3. BACKWASH IS 3" PIPE (GROOVED).
4. MAXIMUM PRESSURE: 80 psi (5.5 bar).
5. MAXIMUM TEMPERATURE: 100°F (37.8°C).
6. SPECIFIED MAXIMUM FLOWRATE OF 310 gpm (70 m³/hr).
7. SPECIFIED MINIMUM BACKWASH FLOWRATE OF 188 gpm (43 m³/hr).
8. FINISH: AS ASSEMBLED.
9. POWER REQUIREMENT: 3/60/460V.
10. NEMA 4X MOTOR STARTER ENCLOSURE WITH SAFETY DISCONNECT, H.O.A. SWITCH, 24 HR BACKWASH TIMER, AND BACKWASH CYCLE TIMER.
11. APPROXIMATE DRY WEIGHT (INCLUDING 560 lbs GRAVEL & 1300 lbs SAND): 2946 lbs (1336 kg).
12. MINIMUM PIPE SIZE TO STS SYSTEM IS 4" PIPE.
13. FLOODED SUCTION REQUIRED.

COMPONENT LIST:

- ① ELECTRICAL CONTROL BOX 460V 60Hz W/120V TRANSFORMER.
- ② MEDIA TANK: 48" DIAMETER STAINLESS STEEL FILTER.
- ③ PUMP: 5 HP CENTRIFUGAL, 3500 rpm, TEFC, 460V, 60Hz, CAST IRON.
- ④ INLET/OUTLET PRESSURE GAUGES: 0-100 psi, GLYCERIN-FILLED.
- ⑤ MEDIA: 10 MICRON AT 95% EFFICIENCY - STANDARD
5 MICRON AT 90% EFFICIENCY - OPTIONAL
- ⑥ UNDERDRAIN: STAINLESS STEEL UNDERDRAIN, STAINLESS STEEL ELEMENTS W/ V-SHAPED SLOTS.
- ⑦ BASKET STRAINER, CAST IRON.

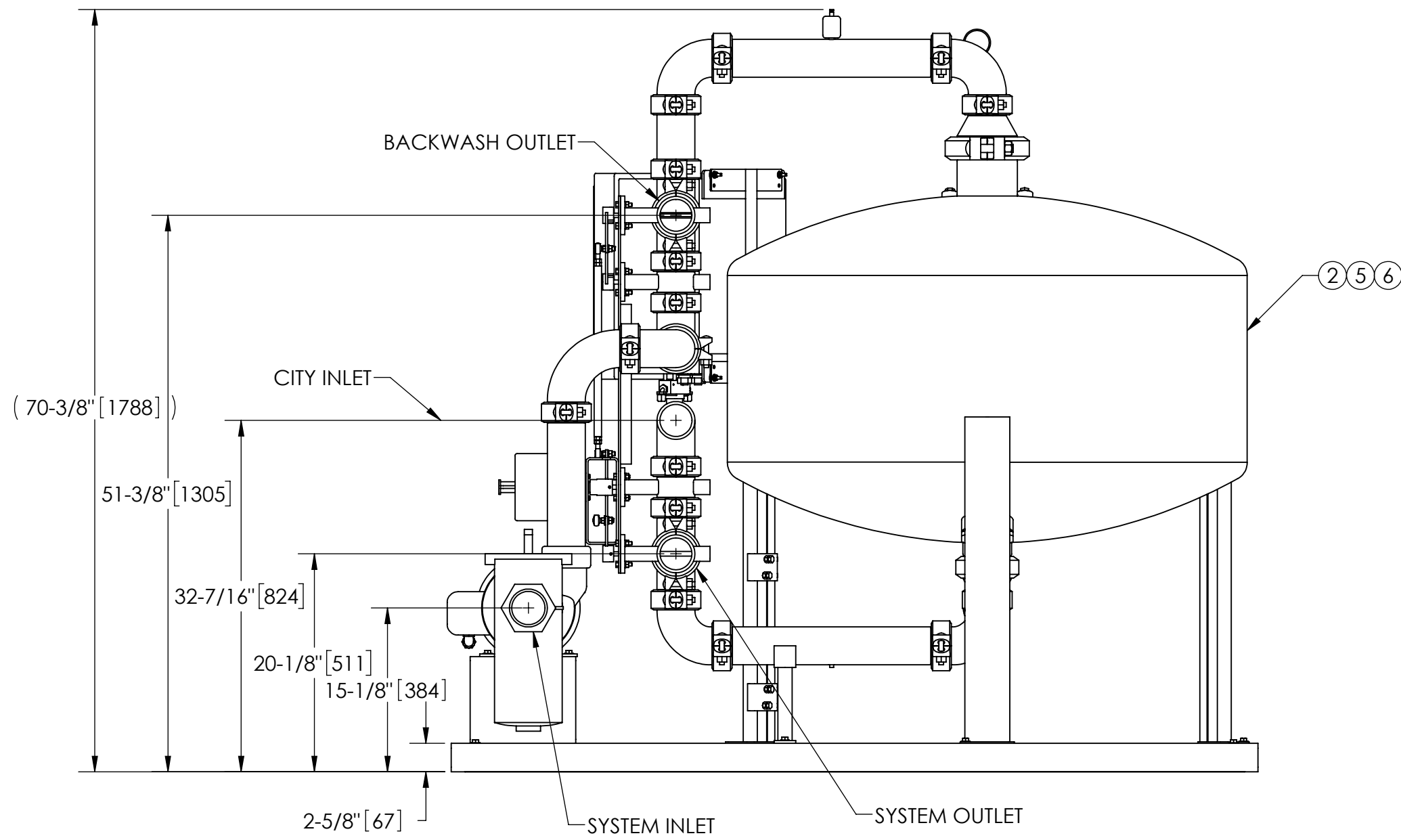

SUBMITTAL DRAWING

This drawing is submitted for spatial consideration only. Do not pre-plumb to these dimensions.

<small>UNLESS OTHERWISE SPECIFIED: DIMENSIONS ARE IN: INCHES (mm) TOLERANCES ARE: FRACTIONS DECIMALS ANGLES ± 1" .XX ± .01 ± 1/4" .XXX ± .005 ± 1/8" .XXXX ± .0005</small>	ENGINEERED FOR: STANDARD					
	APPROVALS	DATE				
	DO NOT SCALE DRAWING	DRAWN: DLW	3/15/06	TITLE STS-48-310-A-C, SS MEDIA SYSTEM, CITY BW, AUTO, 460V 60HZ		
	MATERIAL: PER LAKOS SPEC	ENGR: β	3/17/06			
FINISH: AS ASSEMBLED	REVIEW: -	-	SIZE: C	MODEL NO.	DWG NO. 117936	REV. L
	WORK ORDER	QTY.	SCALE: 1:12	EST. WT. 1086 lb	SHEET 1 OF 1	

DWG NO.

117936

SHT 1

REV L

A