

EXCEPT AS OTHERWISE PROVIDED BY CONTRACT, THIS DRAWING AND SPECIFICATIONS SHALL NOT BE REPRODUCED, COPIED OR USED AS THE BASIS FOR MANUFACTURE OR SALE OF MATTER DEPICTED HEREIN WITHOUT THE EXPRESSED WRITTEN PERMISSION OF THE LAKOS CORPORATION, OR ITS ASSIGNEES.

REVISION HISTORY				
ECN	REV	DESCRIPTION	DATE	APPROVED
408	G	UPDATED TANK	11/24/20	TPF

THIS DRAWING HAS BEEN GENERATED AND IS MAINTAINED BY A CAD SYSTEM. CHANGES SHALL ONLY BE INCORPORATED AS DIRECTED BY AN APPROVED ENGINEERING CHANGE ORDER (ECO). PAPER COPIES ARE UNCONTROLLED.

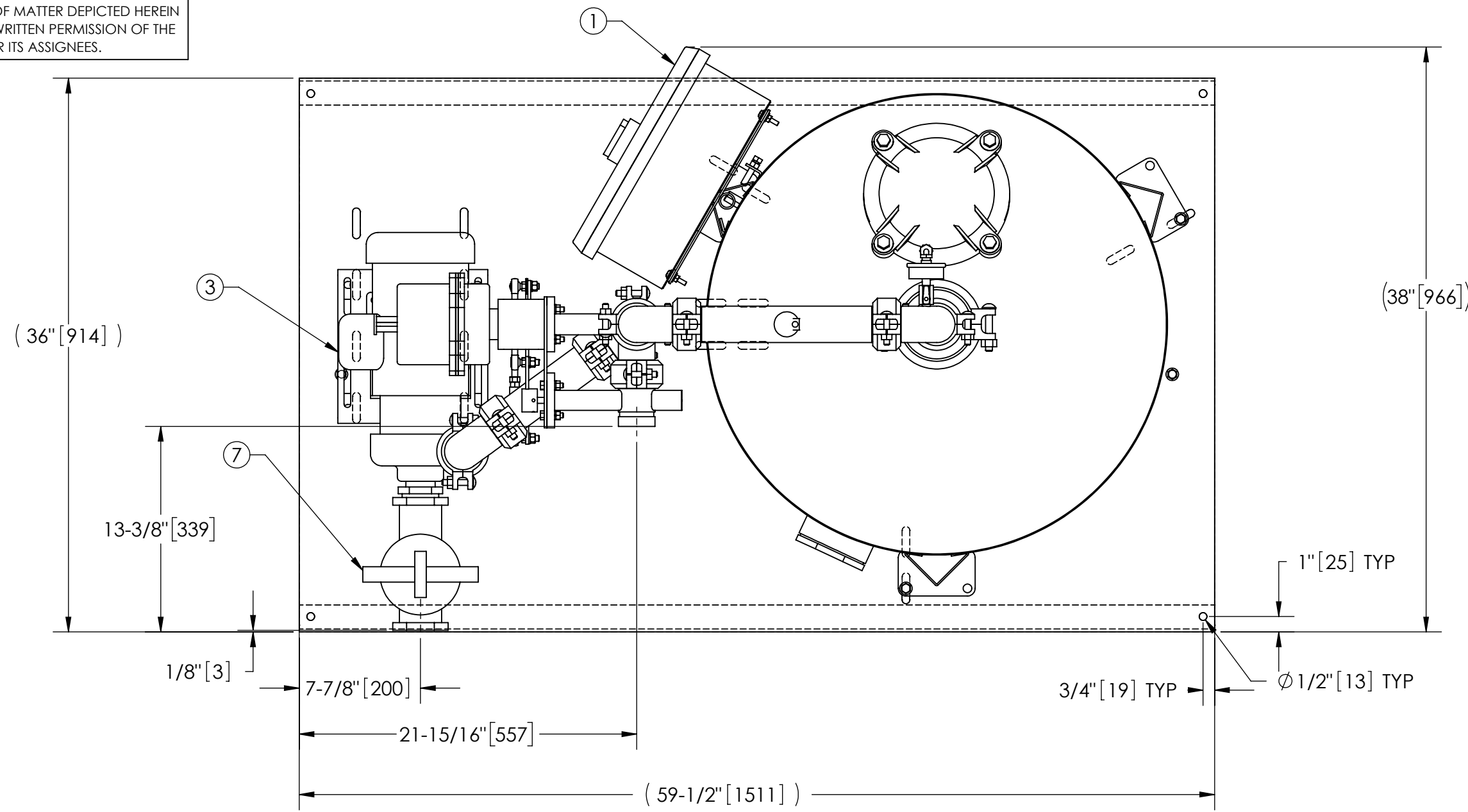

NOTES:

- INLET IS 2" PIPE (NPT).
- OUTLET IS 2" PIPE (GROOVED).
- BACKWASH IS 2" PIPE (GROOVED).
- MAXIMUM PRESSURE: 100 psi (6.9 bar).
- MAXIMUM TEMPERATURE: 100°F (37.8°C).
- SPECIFIED MAXIMUM FLOWRATE OF 110 gpm (25 m³/hr).
- SPECIFIED MINIMUM BACKWASH FLOWRATE OF 73 gpm (17 m³/hr).
- FINISH: AS ASSEMBLED.
- POWER REQUIREMENT: 3/60/460V.
- NEMA 4X MOTOR STARTER ENCLOSURE WITH SAFETY DISCONNECT, H.O.A. SWITCH, 24 HR BACKWASH TIMER, AND BACKWASH CYCLE TIMER.
- APPROXIMATE DRY WEIGHT (INCLUDING 160 lbs GRAVEL & 500 lbs SAND): 1339 lbs (607 kg).
- MINIMUM PIPE SIZE TO STS SYSTEM IS 2-1/2" PIPE.
- FLOODED SUCTION REQUIRED.

COMPONENT LIST:

- ELECTRICAL CONTROL BOX 460V 60Hz W/120V TRANSFORMER.
- MEDIA TANK: 30" DIAMETER STAINLESS STEEL FILTER.
- PUMP: 2 HP CENTRIFUGAL, 3500 rpm, TEFC, 460V, 60Hz, CAST IRON.
- INLET/OUTLET PRESSURE GAUGES: 0-100 psi, GLYCERIN-FILLED.
- MEDIA: 10 MICRON AT 95% EFFICIENCY - STANDARD  
5 MICRON AT 90% EFFICIENCY - OPTIONAL
- UNDERDRAIN: STAINLESS STEEL UNDERDRAIN, STAINLESS STEEL ELEMENTS W/ V-SHAPED SLOTS.
- BASKET STRAINER, CAST IRON.

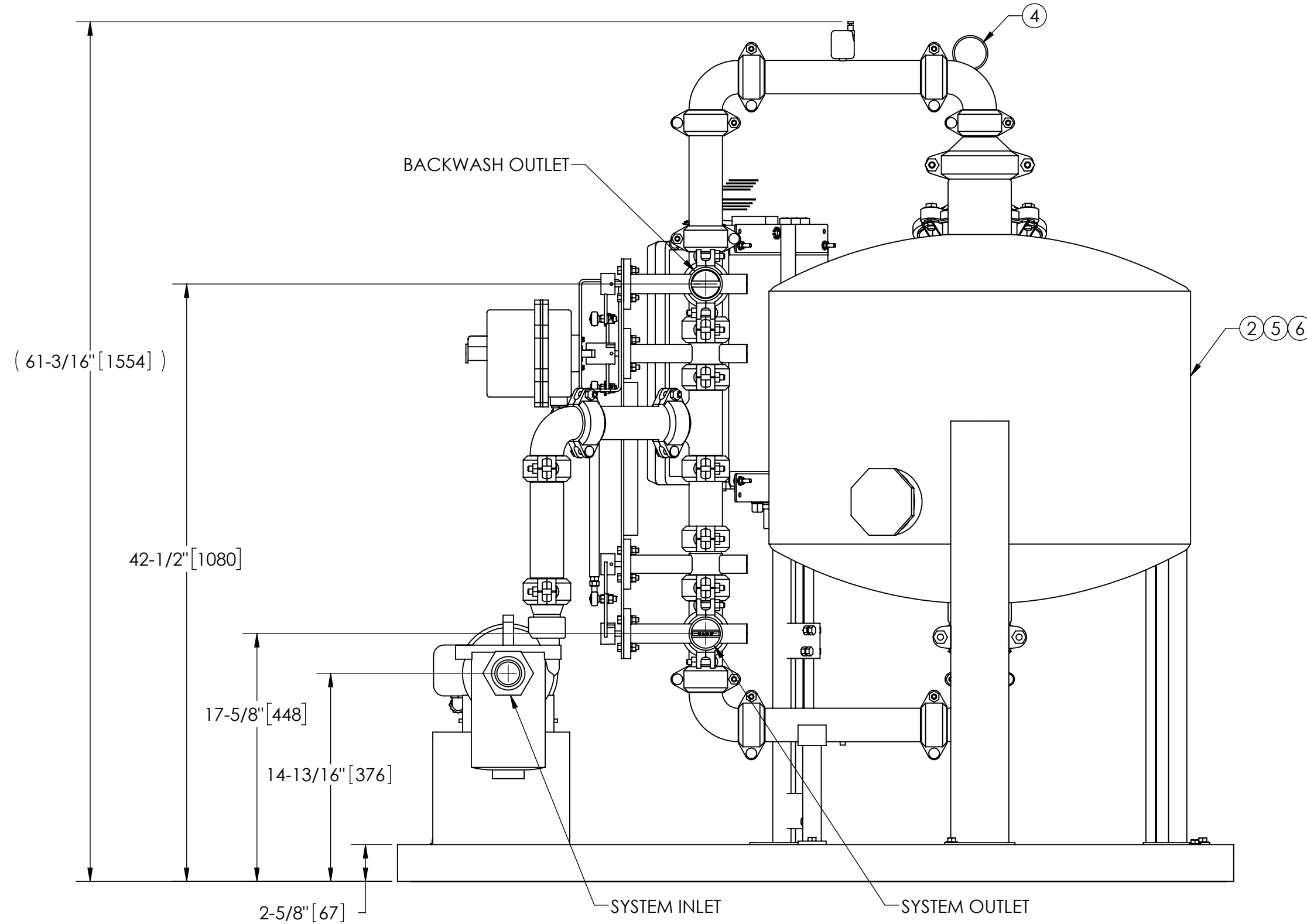

**SUBMITTAL DRAWING**

This drawing is submitted for spatial consideration only. Do not pre-plumb to these dimensions.

UNLESS OTHERWISE SPECIFIED: DIMENSIONS ARE IN: INCHES (mm) TOLERANCES ARE: FRACTIONS DECIMALS ANGLES ± 1" .XX ± .01 ± 1/4" .XXX ± .005 .XXXX ± .0005		ENGINEERED FOR: <b>STANDARD</b>			
DO NOT SCALE DRAWING		APPROVALS	DATE	TITLE	
MATERIAL PER LAKOS SPEC		DRAWN ADJ/DLW	4/11/06	STS-30-110-A-S, SS MEDIA SYSTEM, SYSTEM BW, AUTO, 460V 60HZ	
FINISH AS ASSEMBLED		ENGR	-	SIZE C	MODEL NO.
WORK ORDER		REVIEW	-	DWG NO.	117978
		QTY.	-	EST. WT.	679 lb
				SHEET	1 OF 1

DWG NO. 117978 SHEET 1 REV. G