

EXCEPT AS OTHERWISE PROVIDED BY CONTRACT, THIS DRAWING AND SPECIFICATIONS SHALL NOT BE REPRODUCED, COPIED OR USED AS THE BASIS FOR MANUFACTURE OR SALE OF MATTER DEPICTED HEREIN WITHOUT THE EXPRESSED WRITTEN PERMISSION OF THE LAKOS CORPORATION, OR ITS ASSIGNEES.

REVISION HISTORY				
ECN	REV	DESCRIPTION	DATE	APPROVED
408	G	UPDATED TANK	11/20/20	TPF

THIS DRAWING HAS BEEN GENERATED AND IS MAINTAINED BY A CAD SYSTEM. CHANGES SHALL ONLY BE INCORPORATED AS DIRECTED BY AN APPROVED ENGINEERING CHANGE ORDER (ECO). PAPER COPIES ARE UNCONTROLLED.

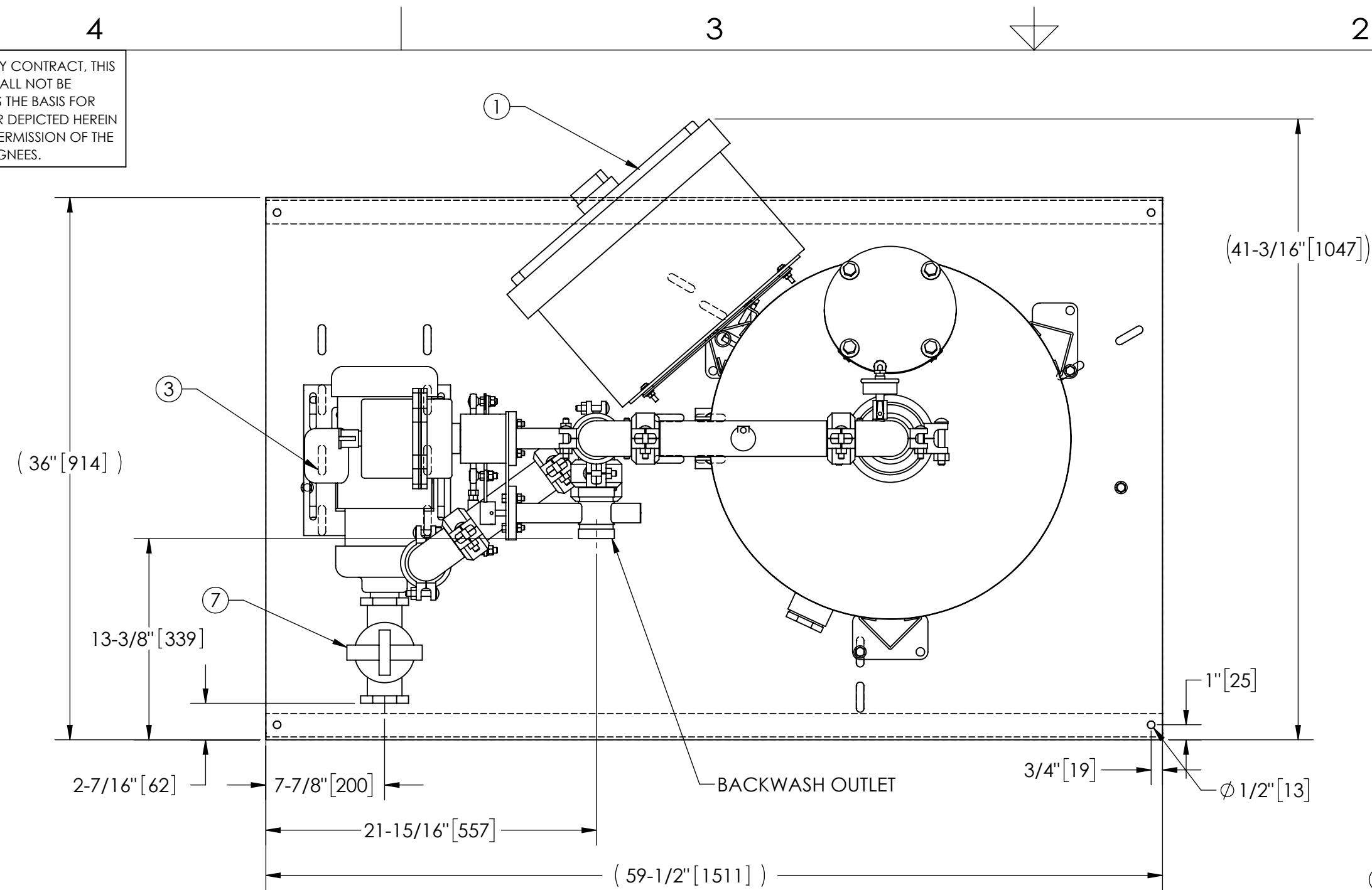

NOTES:

1. INLET IS 1-1/2" PIPE (NPT).
2. OUTLET IS 2" PIPE (GROOVED).
3. BACKWASH IS 2" PIPE (GROOVED).
4. MAXIMUM PRESSURE: 100 psi (6.9 bar).
5. MAXIMUM TEMPERATURE: 100°F (37.8°C).
6. SPECIFIED MAXIMUM FLOWRATE OF 75 gpm (17 m³/hr).
7. SPECIFIED MINIMUM BACKWASH FLOWRATE OF 40 gpm (9 m³/hr).
8. FINISH: AS ASSEMBLED.
9. POWER REQUIREMENT: 3/60/460V.
10. NEMA 4X MOTOR STARTER ENCLOSURE WITH SAFETY DISCONNECT, H.O.A. SWITCH, 24 HR BACKWASH TIMER, AND BACKWASH CYCLE TIMER.
11. APPROXIMATE DRY WEIGHT (INCLUDING 120 lbs GRAVEL & 400 lbs SAND): 1198 lbs (543 kg).
12. MINIMUM PIPE SIZE TO STS SYSTEM IS 2" PIPE.
13. FLOODED SUCTION REQUIRED.

COMPONENT LIST:

- 1 ELECTRICAL CONTROL BOX 460V 60Hz W/120V TRANSFORMER.
- 2 MEDIA TANK: 24" DIAMETER STAINLESS STEEL FILTER.
- 3 PUMP: 1-1/2 HP CENTRIFUGAL, 3500 rpm, TEFC, 460V, 60Hz, CAST IRON.
- 4 INLET/OUTLET PRESSURE GAUGES: 0-100 psi, GLYCERIN-FILLED.
- 5 MEDIA: 10 MICRON AT 95% EFFICIENCY - STANDARD
5 MICRON AT 90% EFFICIENCY - OPTIONAL
- 6 UNDERDRAIN: STAINLESS STEEL UNDERDRAIN, STAINLESS STEEL ELEMENTS W/ V-SHAPED SLOTS.
- 7 BASKET STRAINER, CAST IRON.

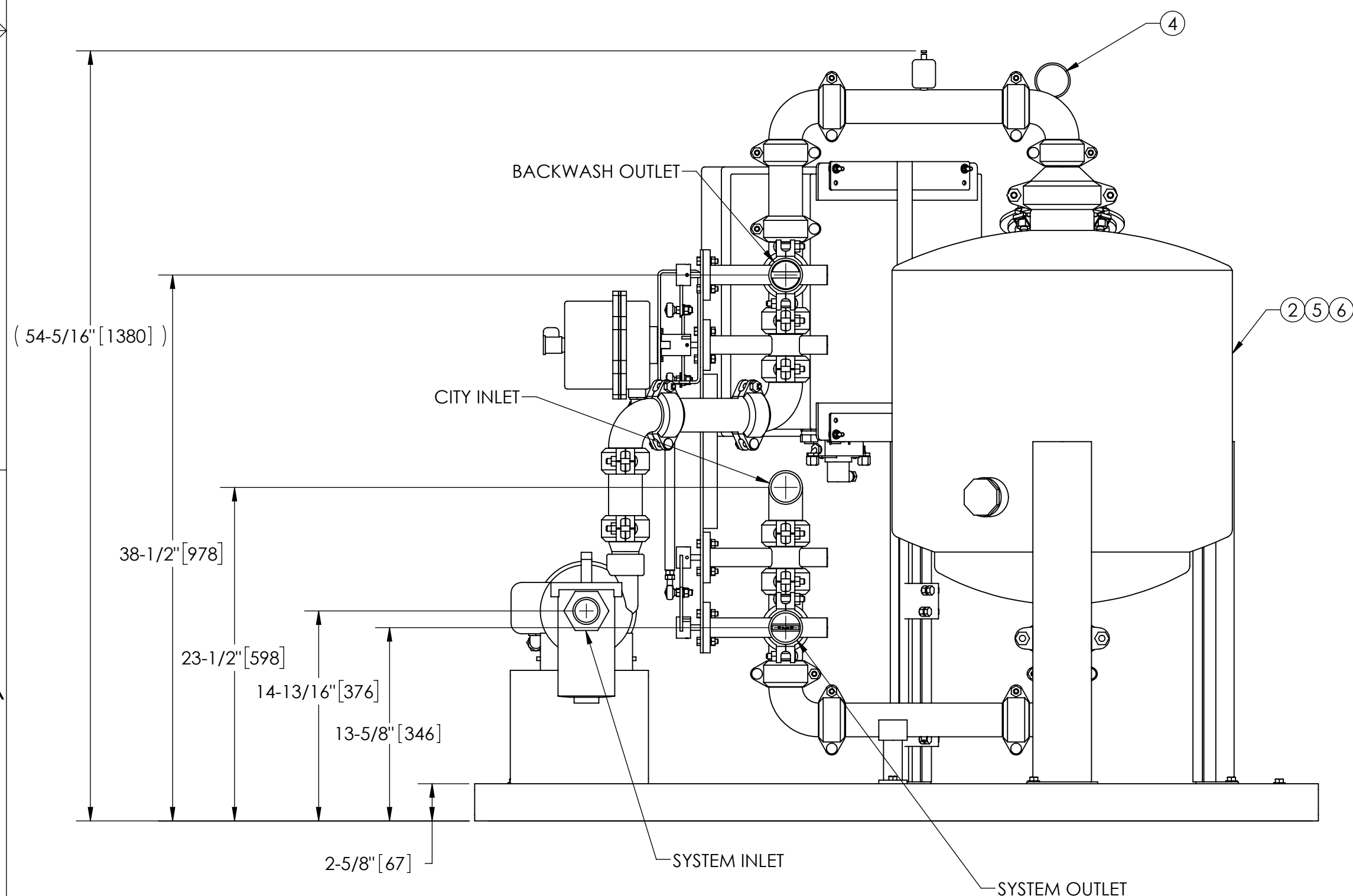

SUBMITTAL DRAWING

This drawing is submitted for spatial consideration only. Do not pre-plumb to these dimensions.

UNLESS OTHERWISE SPECIFIED: DIMENSIONS ARE IN: INCHES (mm) TOLERANCES ARE: FRACTIONS DECIMALS ANGLES ± 1" .XX ± .01 ± 1/4" XXX ± .005 XXXX ± .0005	ENGINEERED FOR: STANDARD			FRESNO, CALIFORNIA WWW.LAKOS.COM	
	APPROVALS	DATE		TITLE	
DO NOT SCALE DRAWING	DRAWN ADJ	5/21/10	STS-24-075-A-C, SS MEDIA SYSTEM, CITY BW, AUTO, 460V 60HZ		
MATERIAL PER LAKOS SPEC	ENGR ADJ	5/24/10	SIZE C	MODEL NO.	DWG NO. 117944
FINISH AS ASSEMBLED	REVIEW -	-	SCALE 1:8	EST. WT. 678 lb	SHEET 1 OF 1
	WORK ORDER	QTY.			

DWG. NO. 117944 SHEET 1 REV. G