

EXCEPT AS OTHERWISE PROVIDED BY CONTRACT, THIS DRAWING AND SPECIFICATIONS SHALL NOT BE REPRODUCED, COPIED OR USED AS THE BASIS FOR MANUFACTURE OR SALE OF MATTER DEPICTED HEREIN WITHOUT THE EXPRESSED WRITTEN PERMISSION OF THE LAKOS CORPORATION, OR ITS ASSIGNEES.

REVISION HISTORY				
ECN	REV	DESCRIPTION	DATE	APPROVED
408	F	UPDATED TANK	11/20/20	TPF

THIS DRAWING HAS BEEN GENERATED AND IS MAINTAINED BY A CAD SYSTEM. CHANGES SHALL ONLY BE INCORPORATED AS DIRECTED BY AN APPROVED ENGINEERING CHANGE ORDER (ECO). PAPER COPIES ARE UNCONTROLLED.

NOTES:

- INLET IS 3" PIPE (NPT).
- OUTLET IS 3" PIPE (GROOVED).
- BACKWASH IS 3" PIPE (GROOVED).
- MAXIMUM PRESSURE: 100 psi (6.9 bar).
- MAXIMUM TEMPERATURE: 100°F (37.8°C).
- SPECIFIED MAXIMUM FLOWRATE OF 165 gpm (38 m³/hr).
- SPECIFIED MINIMUM BACKWASH FLOWRATE OF 106 gpm (24 m³/hr).
- FINISH: AS ASSEMBLED.
- POWER REQUIREMENT: 3/60/460V.
- NEMA 4X MOTOR STARTER ENCLOSURE WITH SAFETY DISCONNECT, H.O.A. SWITCH, 24 HR BACKWASH TIMER, AND BACKWASH CYCLE TIMER.
- APPROXIMATE DRY WEIGHT (INCLUDING 240 lbs GRAVEL & 800 lbs SAND): 2000 lbs (907 kg).
- MINIMUM PIPE SIZE TO STS SYSTEM IS 4" PIPE.
- FLOODED SUCTION REQUIRED.

COMPONENT LIST:

- ELECTRICAL CONTROL BOX 460V 60Hz W/120V TRANSFORMER.
- MEDIA TANK: 36" DIAMETER STAINLESS STEEL FILTER.
- PUMP: 3 HP CENTRIFUGAL, 3500 rpm, TEFC, 460V, 60Hz, CAST IRON.
- INLET/OUTLET PRESSURE GAUGES: 0-100 psi, GLYCERIN-FILLED.
- MEDIA: 10 MICRON AT 95% EFFICIENCY - STANDARD  
5 MICRON AT 90% EFFICIENCY - OPTIONAL
- UNDERDRAIN: STAINLESS STEEL UNDERDRAIN, STAINLESS STEEL ELEMENTS W/ V-SHAPED SLOTS.
- BASKET STRAINER, CAST IRON.

**SUBMITTAL DRAWING**

This drawing is submitted for spatial consideration only. Do not pre-plumb to these dimensions.

UNLESS OTHERWISE SPECIFIED: DIMENSIONS ARE IN: INCHES (mm) TOLERANCES ARE: FRACTIONS    DECIMALS    ANGLES $\pm 1"$ .XX $\pm .01$ $\pm 1/4^\circ$ XXX $\pm .005$ XXXX $\pm .0005$	ENGINEERED FOR:		 FRESNO, CALIFORNIA WWW.LAKOS.COM					
	STANDARD							
	DO NOT SCALE DRAWING	APPROVALS	DATE	TITLE STS-36-165-A-C, SS MEDIA SYSTEM, CITY BW, AUTO, 460V 60HZ				
	MATERIAL	ADJ/DLW	3/15/06					
FINISH	ENGR	-	SIZE	MODEL NO.	DWG NO.	REV.		
AS ASSEMBLED	REVIEW	-	C		117979	F		
	WORK ORDER	-	SCALE	1:8	EST. WT.	960 lb	SHEET	1 OF 1

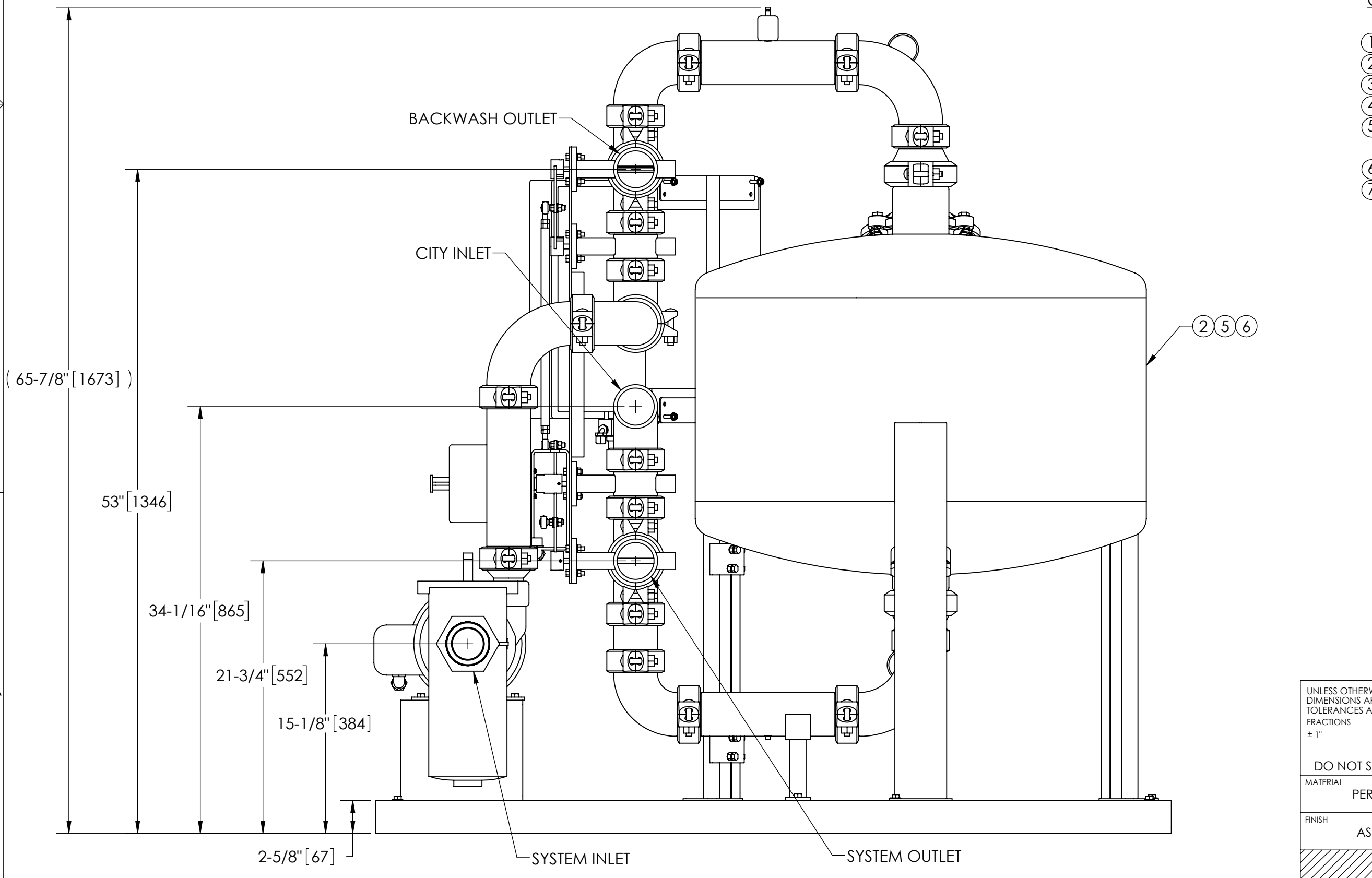
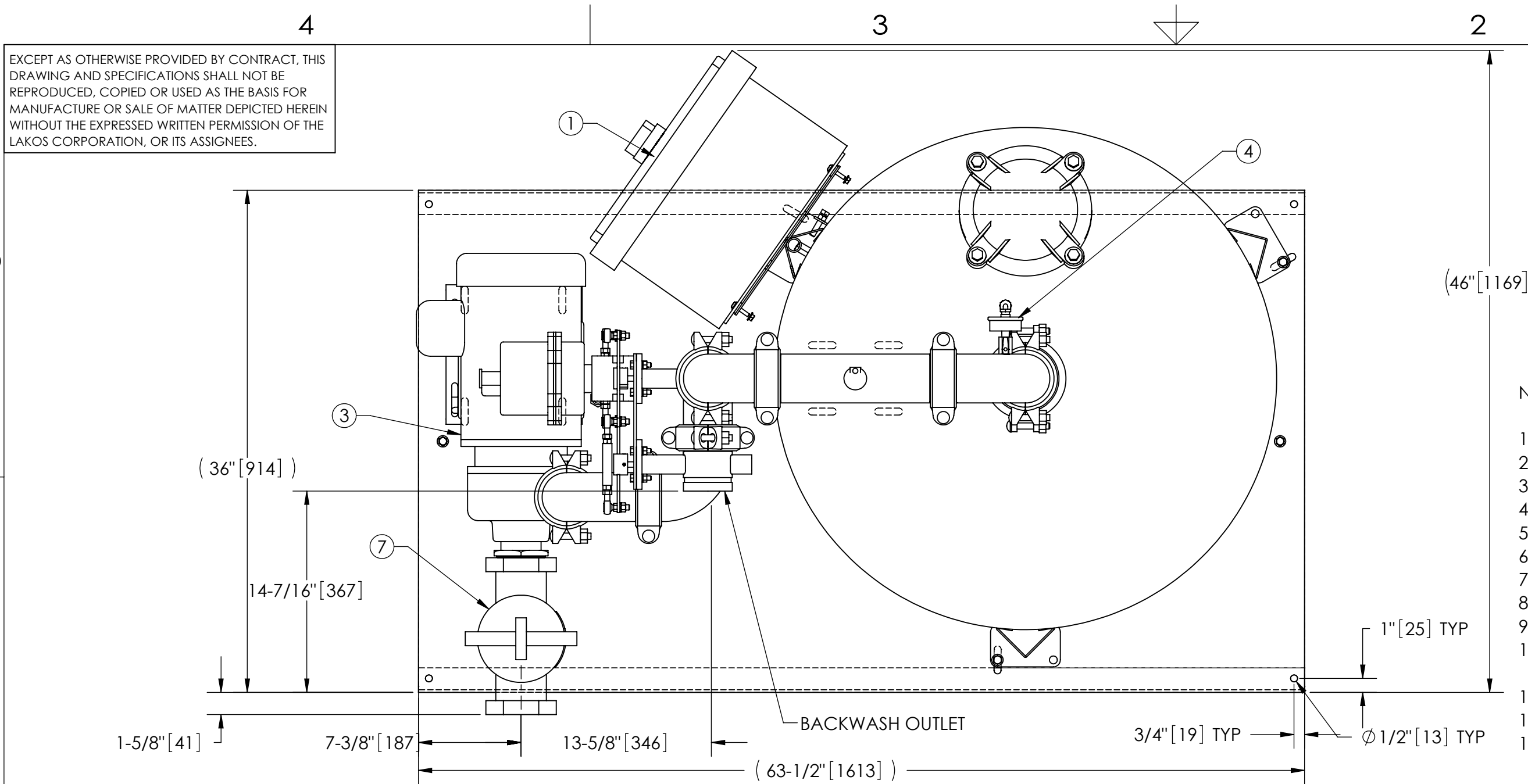

DWG NO. 117979 SHEET 1 REV. F